



Submersible Drainage Pumps,  
Submersible Sewage Pumps, Mixers

---

Made in Italy



## Submersible electropumps with Vortex impeller

Power:	0.25÷1.5 kW
Delivery	G 1 <sup>1</sup> / <sub>4</sub> - G 1 <sup>1</sup> / <sub>2</sub> - G 2"

### Application

The Compatta Series is ideal to pump residential sewage thanks to its small size and mechanical characteristics.

### Characteristic

The main components are fabricated in cast iron GG20. In the standard configuration a lip seal is fitted to the motor side, and a mechanical seal to the impeller side. Also available on request in the new "EVO" version with Double Mechanical seal back to back, located in the oil chamber.

### Motor range

- Squirrel cage motor in 2 poles version
- Thermal protection embedded in the winding
- Insulation class F 155°C
- Motor protection IP 68

### Motor cooling

The cooling of the motor is ensured by the liquid where the pump is submerged.

### Limits of use

- Max. permissible liquid temperature: 40°C with pump fully submerged
- Maximum depth of immersion: 20 mt.
- Permissible pH value: 6-10
- Hydraulic features suitable for liquids with density <math>< 1,1 \text{ kg/dm}^3</math>
- Allowed voltage: 230V/400V  $\pm 5\%$
- Allowed frequency: 50Hz  $\pm 2\%$



### Designation

Compatta 2 M/T G EVO

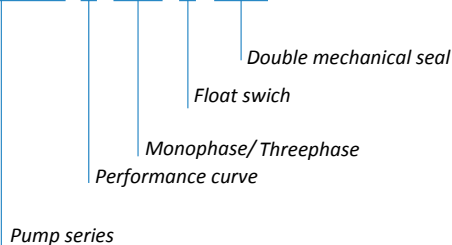

### Performance Overview

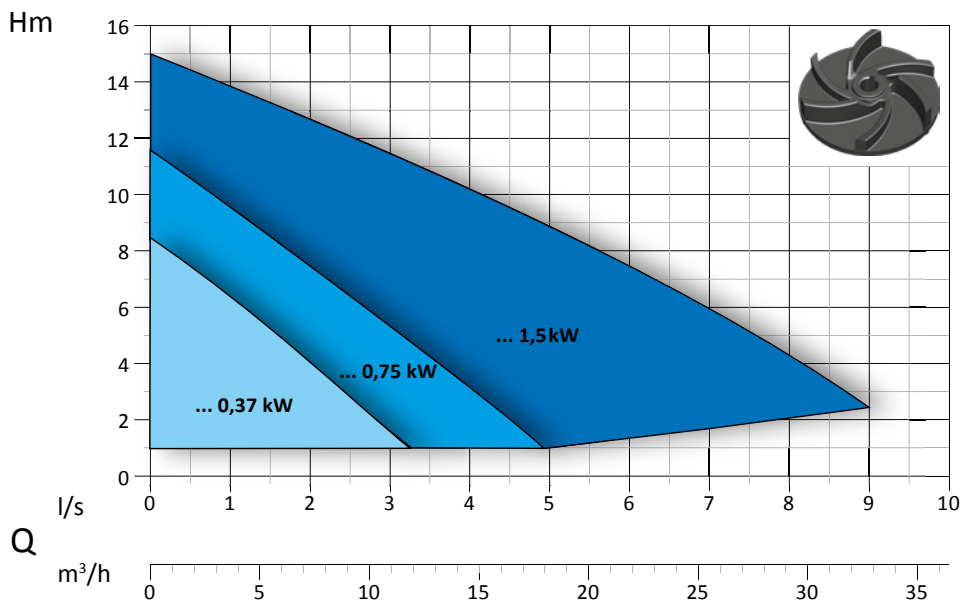

### Curves Identification

- G 1<sup>1</sup>/<sub>4</sub>
- G 1<sup>1</sup>/<sub>2</sub>
- G 2"

### Norms

According to ISO 9906:2012 3B2

### List of components and materials

Handle  
Hard nylon

Motor cover  
Cast Iron GG20

Motor casing  
Cast Iron GG20

Motor shaft  
Stainless steel AISI 420

Electric motor

Rotor

Flange bearing support  
Cast Iron GG20

Seal kit  
Motor side: lip seal  
Impeller side: silicon carbide/ceramic (SIC+CE/Viton)

Impeller  
Cast Iron GG20

Body pump  
Cast iron GG20



### Technology and Features



#### EVO Version

With Double Mechanical Seal in oil chamber  
Motor side: Carbon/Ceramic (CA/CE/Viton)  
Impeller side: Silicon carbide (SIC/SIC/Viton)  
Inspectional oil chamber



#### Relay

For the correct operation of the float switch on the three-phase version.

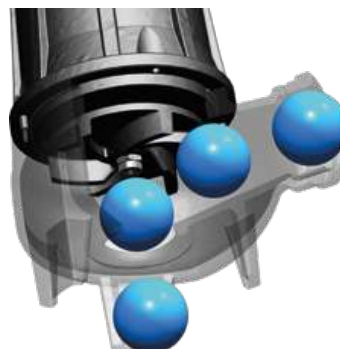

#### Solids handling

Excellent free passage of solids

Vertical Outlet G 1"1/4 - RPM 2850 1/min 2 poles  
 Horizontal Outlet G 1"1/2 - RPM 2850 1/min 2 poles



### Performance Curve

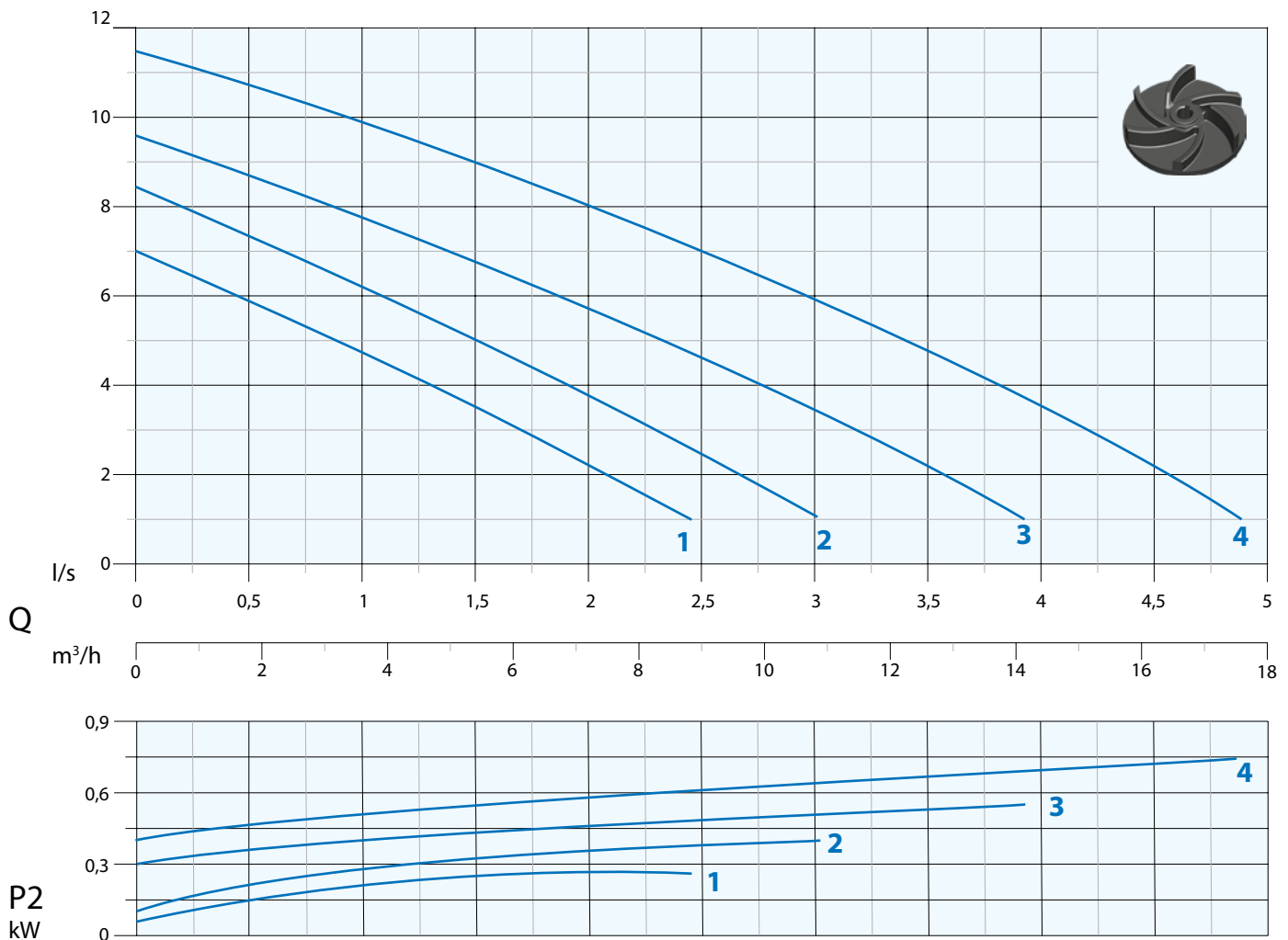

N°	Type	Flow Rate									
		l/s	0,5	1	1,5	2	2,5	3	3,5	4	4,5
		l/m	30	60	90	120	150	180	210	240	270
		m³/h	1,8	3,6	5,4	7,2	9	10,8	12,6	14,4	16,2
1	Compatta 1 M	mt	5,8	4,6	3,5	2,2	1				
2	Compatta 1.5 M/T		7,5	6,1	5	3,8	2,5	1			
3	Compatta 2 M/T		8,8	7,8	6,8	5,8	4,5	3,5	2,1	1	
4	Compatta 3 M/T		10,8	10	9	8	7	6	4,8	3,5	2,1

N°	Type	EVO	Delivery	Free Passage	kW			R.P.M. 1/min	A		Hz	
					P1	P2	HP		1 Phase - 230V	µf		3 Phase - 400V
1	Compatta 1 M		G 1"1/4 (Verticale/Vertical)	30 mm	0,43	0,28	0,4	2850	1,9	7,5	50	
2	Compatta 1.5 M/T				0,55	0,37	0,5		3,5	10		1,2
3	Compatta 2 M/T	•	G 1"1/2	35 mm	0,78	0,56	0,75		3,6	16		1,8
4	Compatta 3 M/T	•			0,90	0,75	1		5,2	20		2,0

• Available EVO version

### Compatta 1-1.5

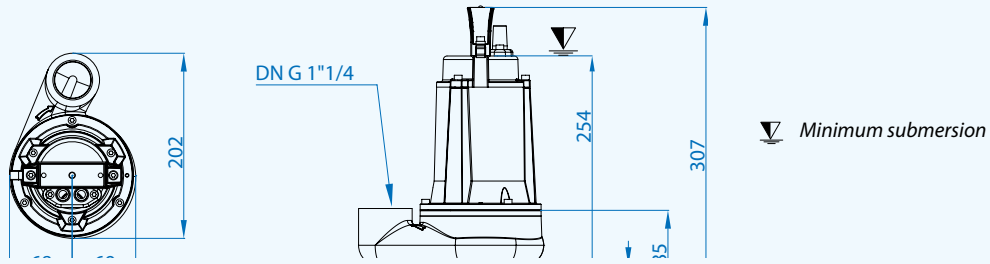

### Compatta 2-3

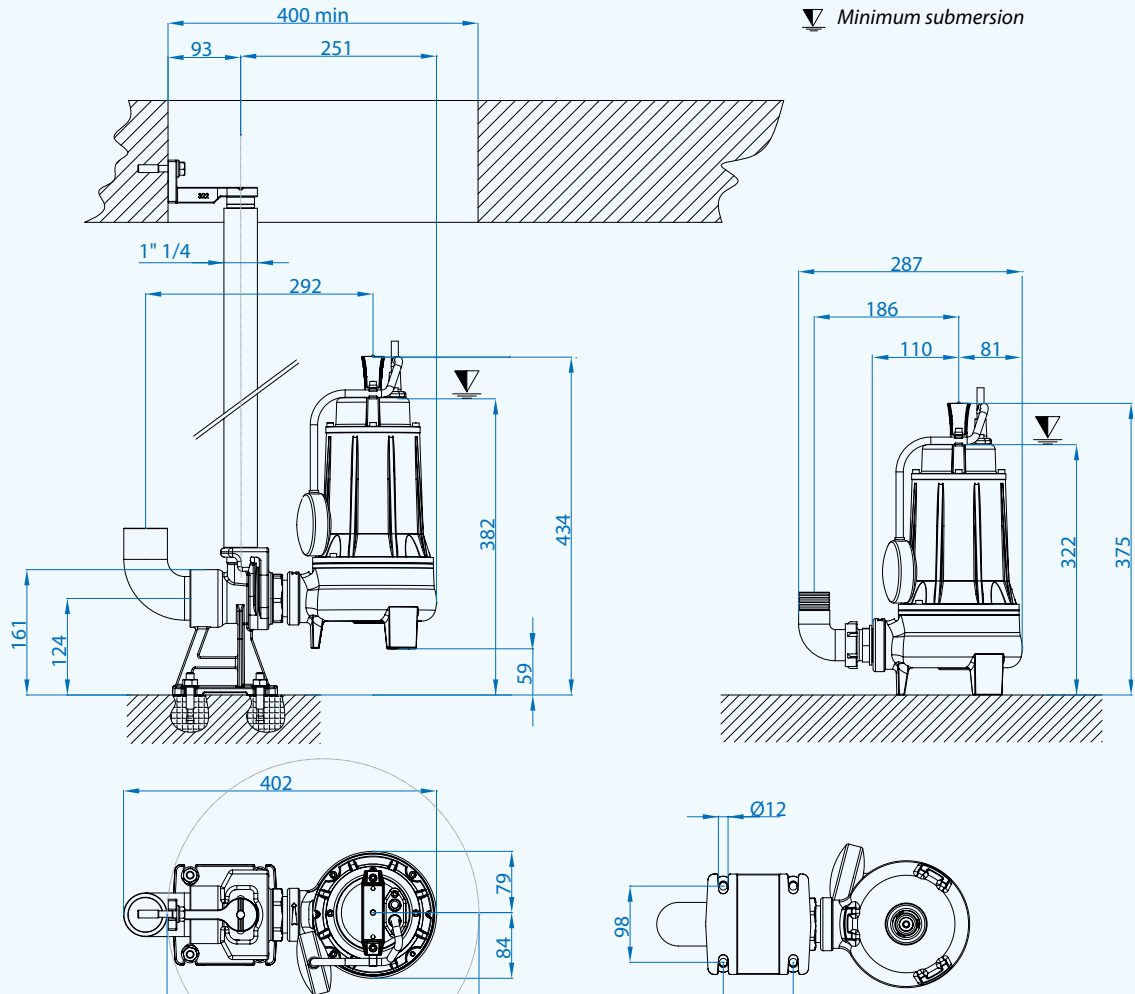

### Cables

Single phase 230V  
H07RN8F 3x1 Ø9 - Schuko plug  
Length 10 mt

Threephase 400V  
H07RN8F 4x1 Ø10 - Free terminals  
Length 10 mt

### Packaging dimension

Tipo - Type	X mm	Y mm	Z mm	Kg
Compatta 1 M				11
Compatta 1.5 M/T	160	330	210	12
Compatta 2 M/T				17
Compatta 3 M/T	200	380	230	17,5

### Optional



Vertical hose connection  
(only Compatta 1-1.5, 1 1/4)



Thread hose connection  
(only Compatta 2-3, 1 1/2)



Automatic coupling foot type:  
EASY E2.1 or E2.2  
(only Compatta 2-3)



For single phase pumps: Control-box with  
external main capacitor

Horizontal Outlet G 2" -  
RPM 2850 1/min 2 poles



### Performance Curve

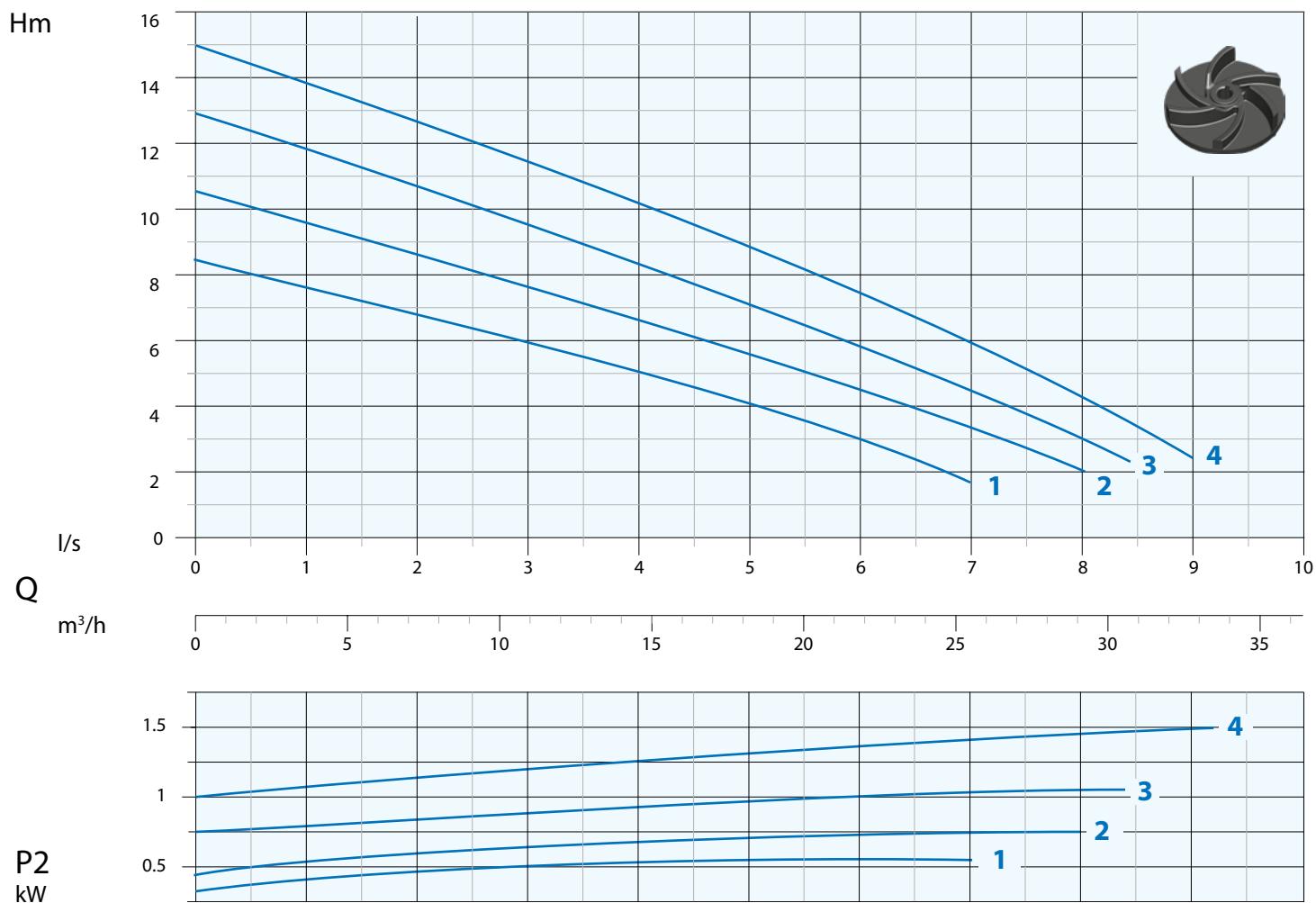

N°	Type	l/s	1	2	3	4	5	6	7	8	9
			l/m	60	120	180	240	300	360	420	480
		m³/h	3,6	7,2	10,8	14,4	18	21,6	25,2	28,8	32,4
1	Compatta 22 M/T	mt	7,5	6,8	6	5	4	2,5	1,5		
2	Compatta 32 M/T		9,5	8,5	7,5	6,5	5,5	4,5	3,4	2	
3	Compatta 4 M/T		11,8	10,5	9,5	8,5	7	5,8	4,5	3	
4	Compatta 55 M/T		13,8	12,5	11,5	10,2	8,9	7,5	6	4,3	2,5

N°	Type	EVO	Delivery	Free Passage	kW			R.P.M. 1/min	A			Hz
					P1	P2	HP		1 Phase - 230V	µf	3 Phase - 400V	
1	Compatta 22 M/T	•	G 2"	40 mm	0,79	0,56	0,75	2850	3,6	16	1,8	50
2	Compatta 32 M/T	•			1,0	0,75	1		5,2	20	2,0	
3	Compatta 4 M/T	•		50 mm	1,6	1,1	1,5		7,6	30	2,9	
4	Compatta 55 M/T	•			2,1	1,5	2		9,9	32	3,7	

• Available EVO version

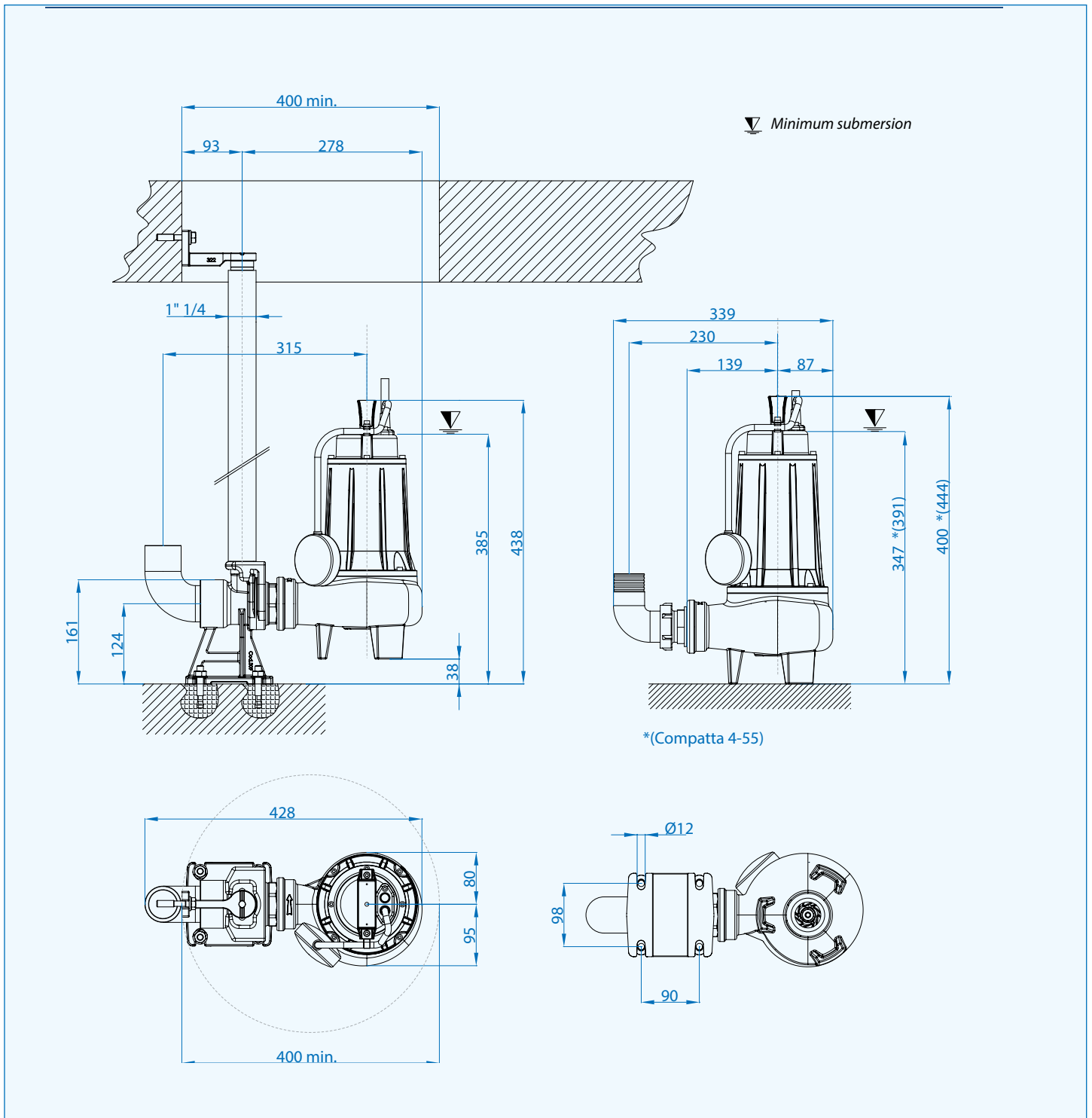

### Cables

Single phase 230V  
H07RN8F 3x1 Ø9 - Schuko plug  
Length 10 mt

Threephase 400V  
H07RN8F 4x1 Ø10 - Free terminals  
Length 10 mt

### Optional



For single phase pumps: Control box with external main capacitor



Automatic coupling foot  
Type: EASY 3.1 or 3.2



Thread hose connection 2"

### Packaging dimension

Type	X mm	Y mm	Z mm	Kg
Compatta 22 M/T	230	450	270	18,5
Compatta 32 M/T				19
Compatta 4 M/T				21
Compatta 55 M/T				22

### Submersible electropumps with Vortex impeller ATEX approved

Power:	<b>0.6÷2.2 kW</b>
Delivery	<b>G 2"</b>



#### Application

The Compatta PRO Series is ideal to pump resi-dential sewage thanks to it's small size and me-chemical characteristics.

The pumps with

0477 II 2G Ex db IIB T4 Gb  
 EPT 17 ATEX 2701 X Ex h IIB T4 Gb  
 0° Ta - 40°

can be used in potentially explosive environments, available on request.

#### Characteristic

The main components are fabricated in cast iron GG20 In the standard configuration a lip seal is fitted to the motor side, and a mechanical seal to the impeller side.

#### Motor range

- Squirrel cage motor in 2 poles version
- Thermal protection T1-T2 embedded in the wind-ing, to be wired to the control panel
- Insulation class F 155°C
- Motor protection IP 68

#### Motor cooling

The cooling of the motor is ensured by the liquid where the pump is submerged

#### Limits of use

- Max. permissible liquid temperature: 40°C with pump fully submerged
- On request, special version (excluded ATEX) to withstand liquid temperature up to 60°C with pump fully submerged, no S1 service
- Maximum depth of immersion: 20 mt
- Permissible pH value: 6-10
- Hydraulic features suitable for liquids with density <math>< 1,1 \text{ kg/dm}^3</math>
- Allowed voltage: 230V/400V  $\pm 5\%$
- Allowed frequency: 50Hz  $\pm 2\%$

#### Designation

**Compatta PRO EX 50 - 2 / 150 M/T G**

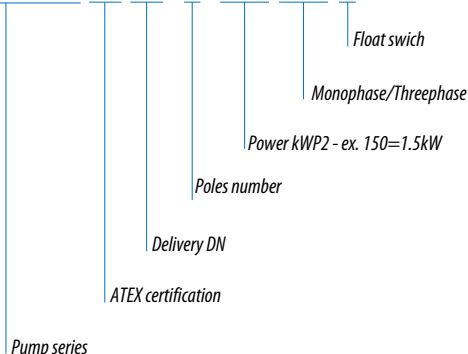

#### Performance Overview

#### Curves Identification

#### Norms

■ G 2"

According to ISO 9906:2012 3B2

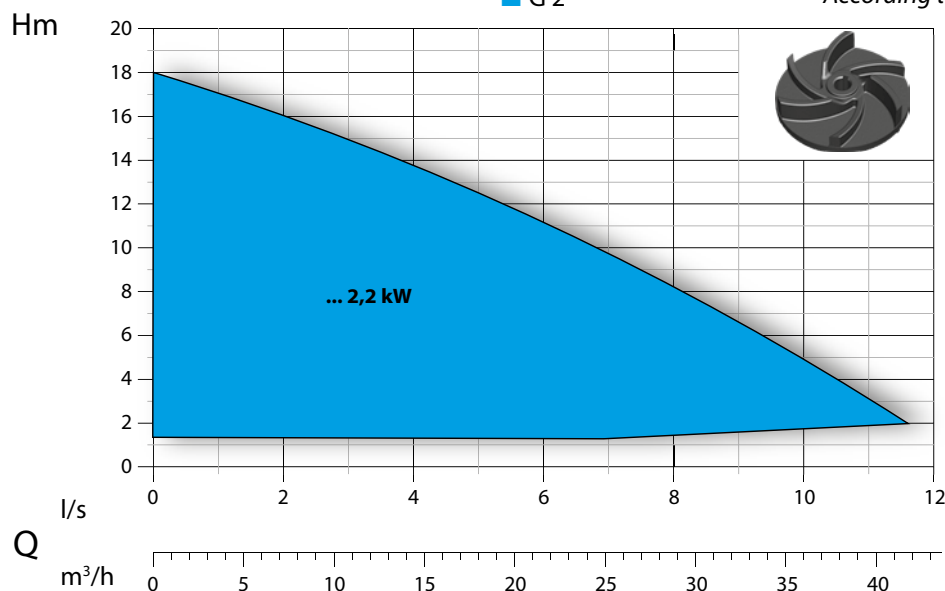



### List of components and materials

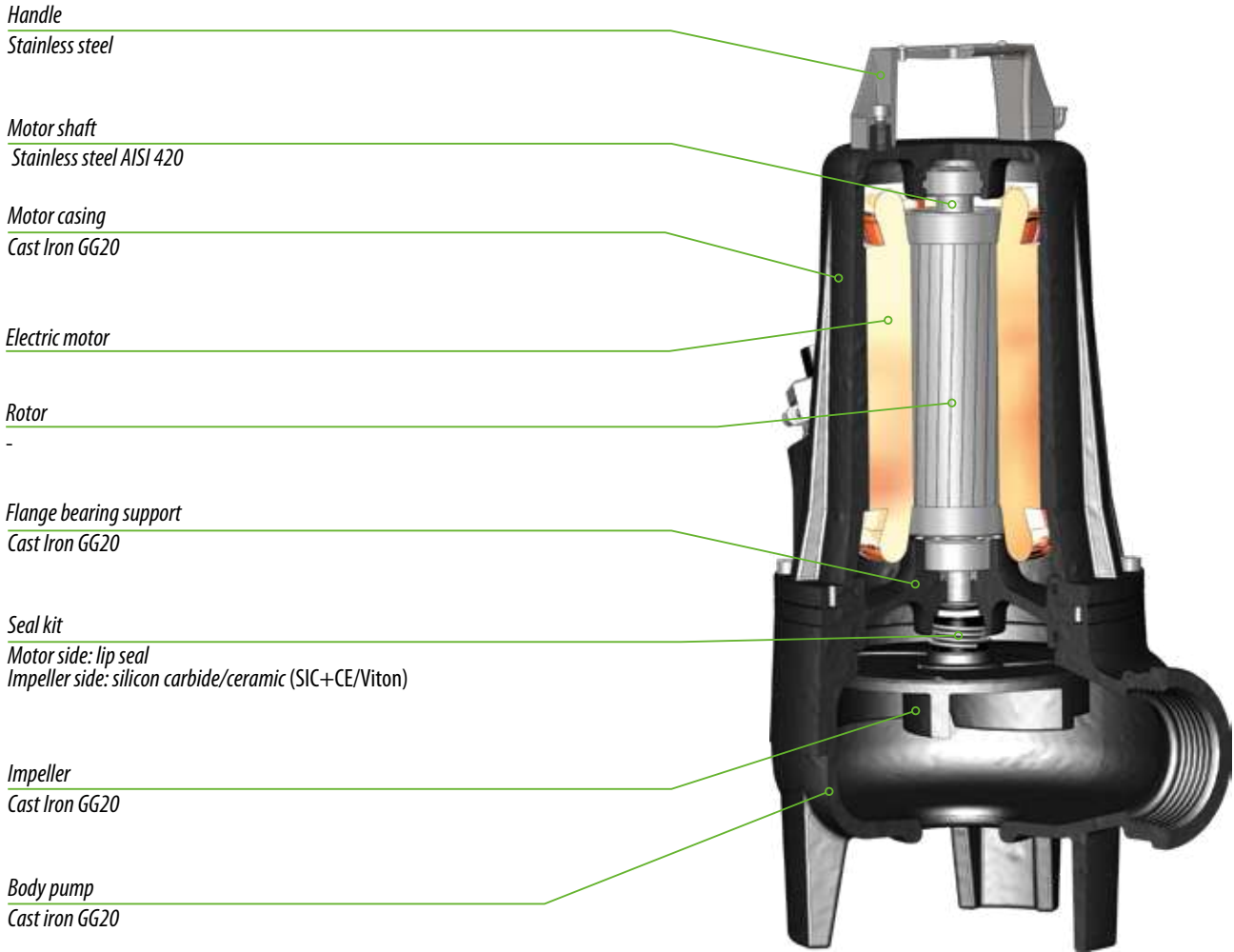

### Technology and Features

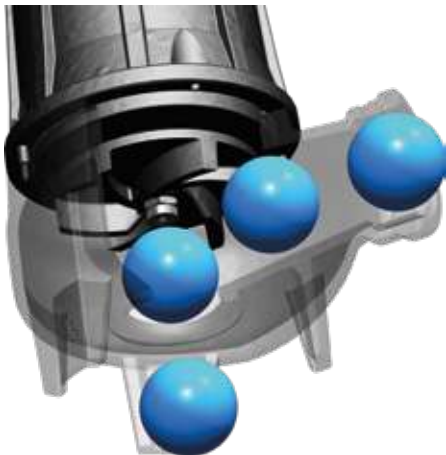

**Solids Handling**  
Full free passage of solids.



**Explosion proof pumps**  
Pumps with explosion proof available on request.



0477 II 2G



Ex db IIB T4 Gb

EPT 17 ATEX 2701 X 0° Ta - 40°



**Cable gland**

The cable gland is made of stainless steel AISI 316 and certified according to the norm ATEX EN 60079-0, EN 60079-1. Standard on all series.

Horizontal Outlet G 2"  
RPM 2850 1/min 2 poles



### Performance Curve

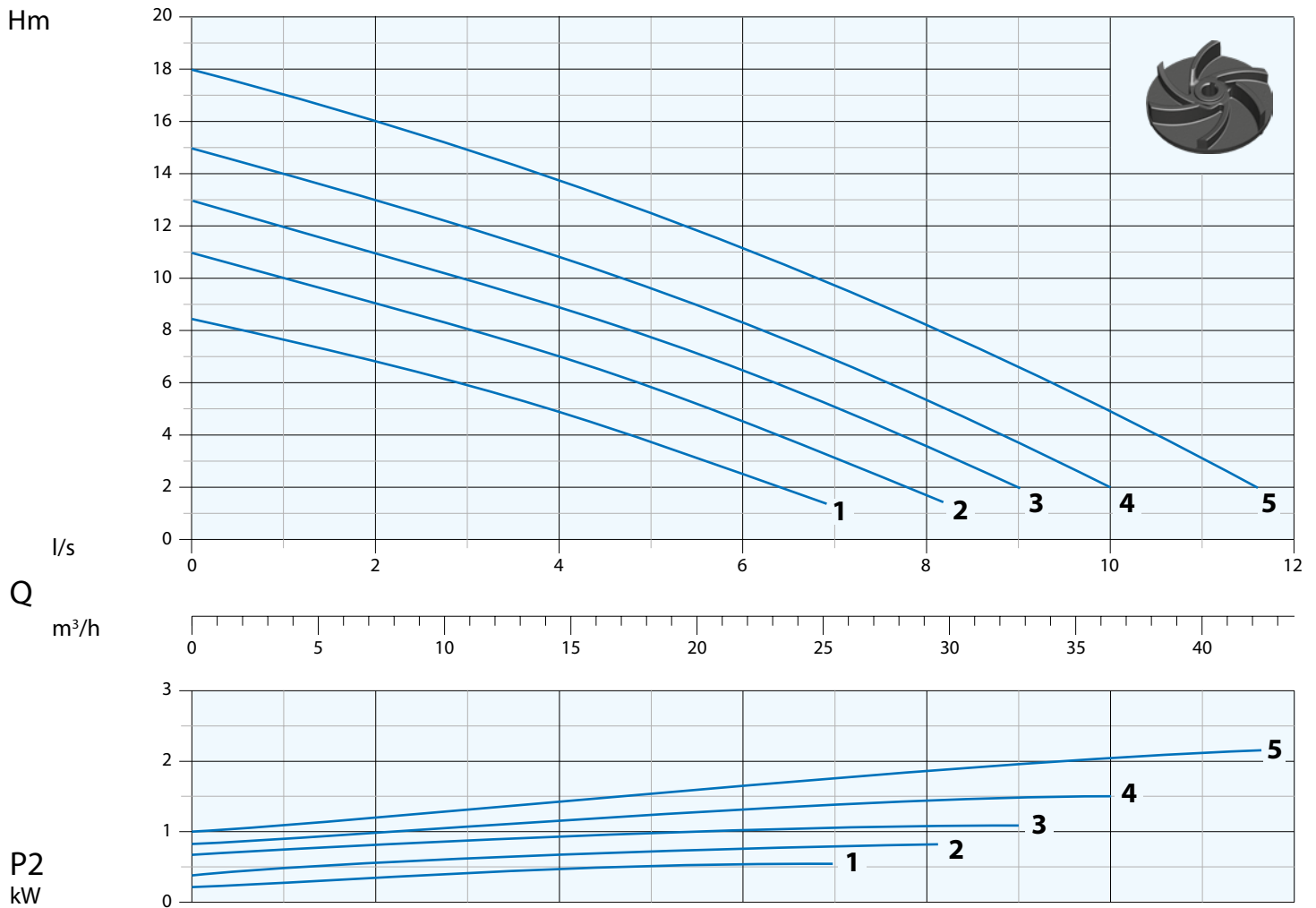

N°	Type	Q (m³/h)									
		1	2	3	4	5	6	7	8	10	11
		60	120	180	240	300	360	420	480	600	660
		3,6	7,2	10,8	14,4	18	21,6	25,2	28,8	36	39,6
1	Compatta PRO 50-2/060 M/T	7,8	7	6	5	3,8	2,5	1			
2	Compatta PRO 50-2/080 M/T	10	9	8	7	5,8	4,5	3	1,5		
3	Compatta PRO 50-2/110 M/T	12	11	10	9	7,8	6,5	5	3,5		
4	Compatta PRO 50-2/150 M/T	14	13	12	10,8	9,5	8,5	7	5,5	2	
5	Compatta PRO 50-2/220 T	17	16	15	13,8	12,5	11	9,5	8,2	5	3

N°	Type	EX	Delivery	Free Passage	kW			R.P.M. 1/min	A			Hz
					P1	P2	HP		1 Phase - 230V	µf	3 Phase - 400V	
1	Compatta PRO 50-2/060 M/T	•	G 2"	50 mm	0,9	0,6	0,8	2850	4,8	20	2,1	50
2	Compatta PRO 50-2/080 M/T	•			1,1	0,8	1		6,0	25	2,4	
3	Compatta PRO 50-2/110 M/T	•			1,4	1,1	1,5		7,4	30	2,7	
4	Compatta PRO 50-2/150 M/T	•			2,0	1,5	2		9,6	40	3,7	
5	Compatta PRO 50-2/220 T	•			2,7	2,2	3				5,2	

• Available explosion proof pump

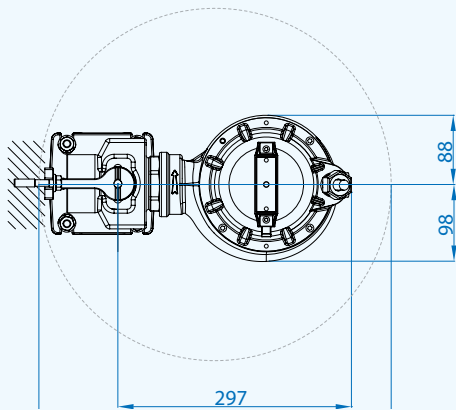
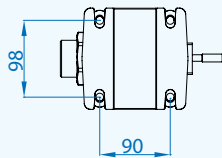
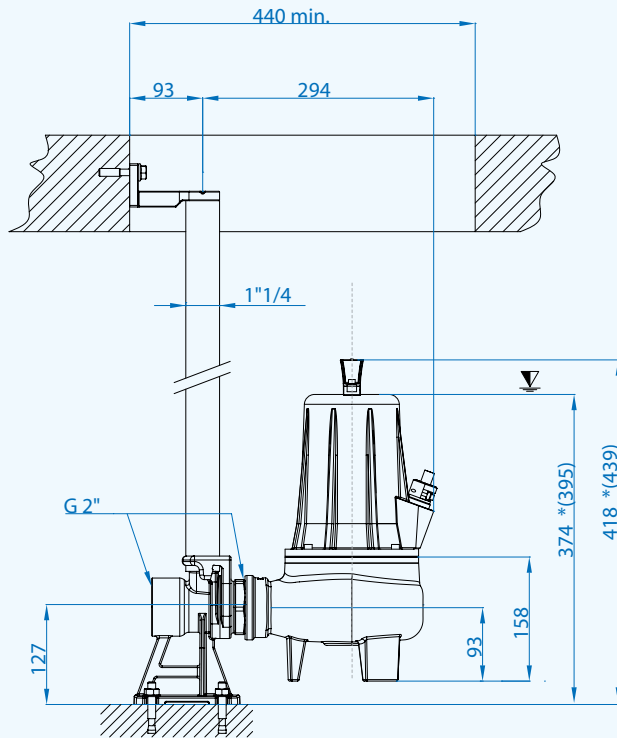

▽ Minimum submersion

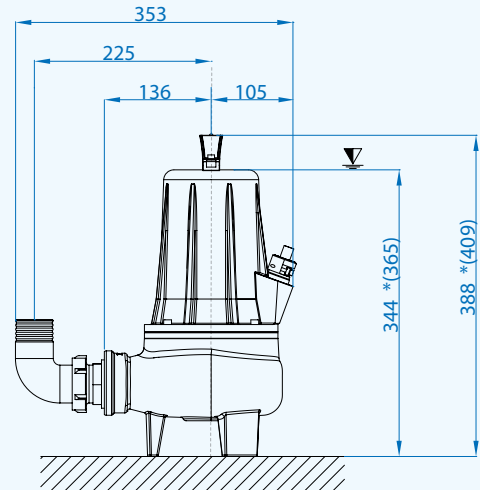

\*(Compatta PRO 50-2/150 M  
Compatta PRO 50-2/220 T)

### Cables

Version	Phases	Cable	Cable cross section mm <sup>2</sup>	mt
Standard	1 ~ 230V	H07RN8F	4x1,5+2x0,50 Ø12*	10
	3 ~ 400V	H07RN8F	4x1,5+2x0,50 Ø12**	10
Verioni/Versions ATEX	1 ~ 230V	NSSHÖU-J	4x1,5+2x0,50 Ø14*	10
	3 ~ 400V	NSSHÖU-J	4x1,5+2x0,50 Ø14**	10

\* Standard with Control-box

\*\*Free terminals

### Packaging dimension

Type	X mm	Y mm	Z mm	Kg
Compatta PRO 50-2/060 M/T	230	450	270	24
Compatta PRO 50-2/080 M/T				24,5
Compatta PRO 50-2/110 M/T				24,5
Compatta PRO 50-2/150 M/T				24,5
Compatta PRO 50-2/220 T				25

### Optional



Automatic coupling foot Type:  
EASY 3.1 or 3.2



Thread hose connection 2"



Explosion proof control  
box available on request

## Submersible electropumps with Vortex impeller

Power:	<b>0.56 ÷ 1.5 kW</b>
Delivery	<b>G 1 1/2" - G 2"</b>



### Application

The Alpha V Series is ideal to pump residential sewage thanks to its small size and mechanical characteristics.

### Characteristic

The main components are fabricated in cast iron GG20. In the standard configuration a lip seal is fitted to the motor side, and a mechanical seal to the impeller side. Also available on request in the new "EVO" version with Double Mechanical seal back to back, located in the oil chamber.

### Motor range

- Squirrel cage motor in 2 poles version
- Thermal protection embedded in the winding
- Insulation class F 155°C
- Motor protection IP 68

### Motor cooling

The cooling of the motor is ensured by the liquid where the pump is submerged.

### Designation

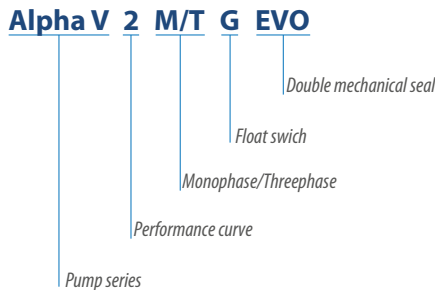

### Limits of use

- Max. permissible liquid temperature: 40°C with pump fully submerged
- Maximum depth of immersion: 20 mt.
- Permissible pH value: 6-10
- Hydraulic features suitable for liquids with density <math>< 1,1 \text{ kg/dm}^3</math>
- Allowed voltage: 230V/400V  $\pm 5\%$
- Allowed frequency: 50Hz  $\pm 2\%$

### Performance Overview

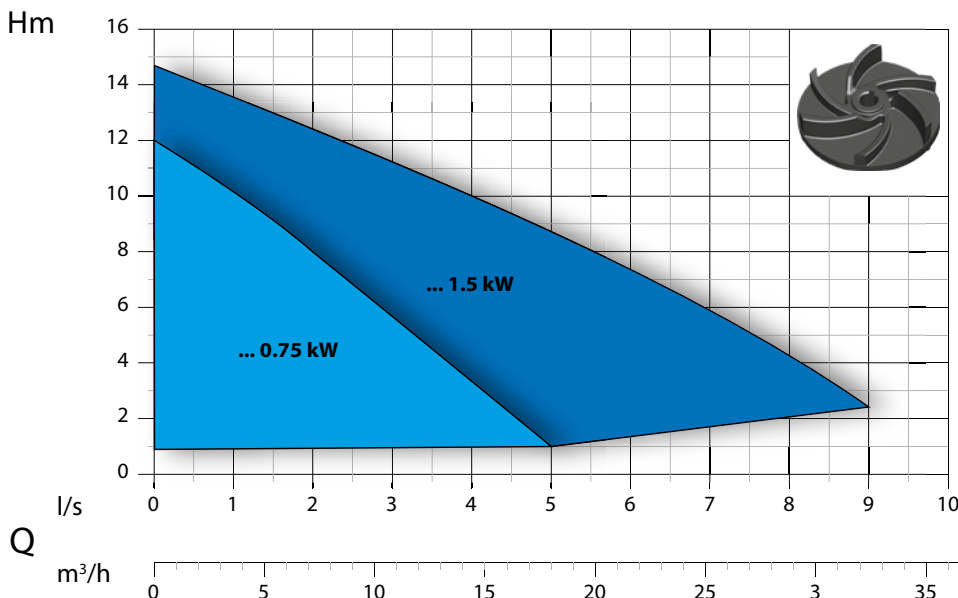

### Curves Identification

- G 1 1/2"
- G 2"

### Norms

According to ISO 9906:2012 3B2

### List of components and materials

Handle  
Hard nylon

Motor cover  
Cast Iron GG20

Motor casing  
Cast Iron GG20

Motor shaft Stainless  
steel AISI 420

Electric motor

Rotor

Flange bearing support  
Cast Iron GG20

Seal kit  
Motor side: lip seal  
Impeller side: silicon carbide/ceramic (SIC+CE/Viton)

Impeller  
Cast Iron GG20

Body pump  
Cast iron GG20

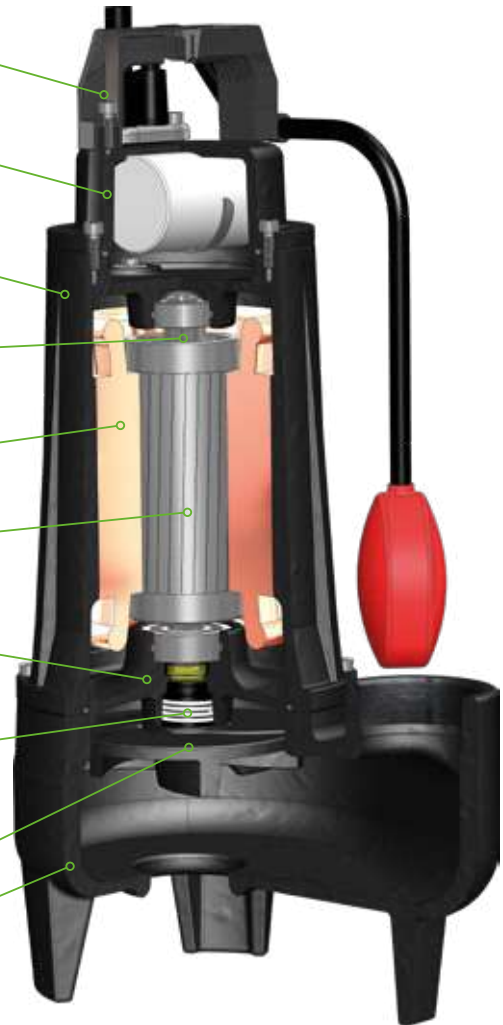

### Technology and Features



**EVO Version**  
With Double Mechanical Seal in oil chamber  
Motor side: Carbon/Ceramic (CA/CE/Viton)  
Impeller side: Silicon carbide (SIC/SIC/Viton)  
Inspectional oil chamber



**Relay**  
For the correct operation of the float switch on the three-phase version.



**Solids handling**  
Excellent free passage of solids

Vertical Outlet G 1"1/2 -  
RPM 2850 1/min 2 poles

Picture for illustration purposes only



### Performance Curve

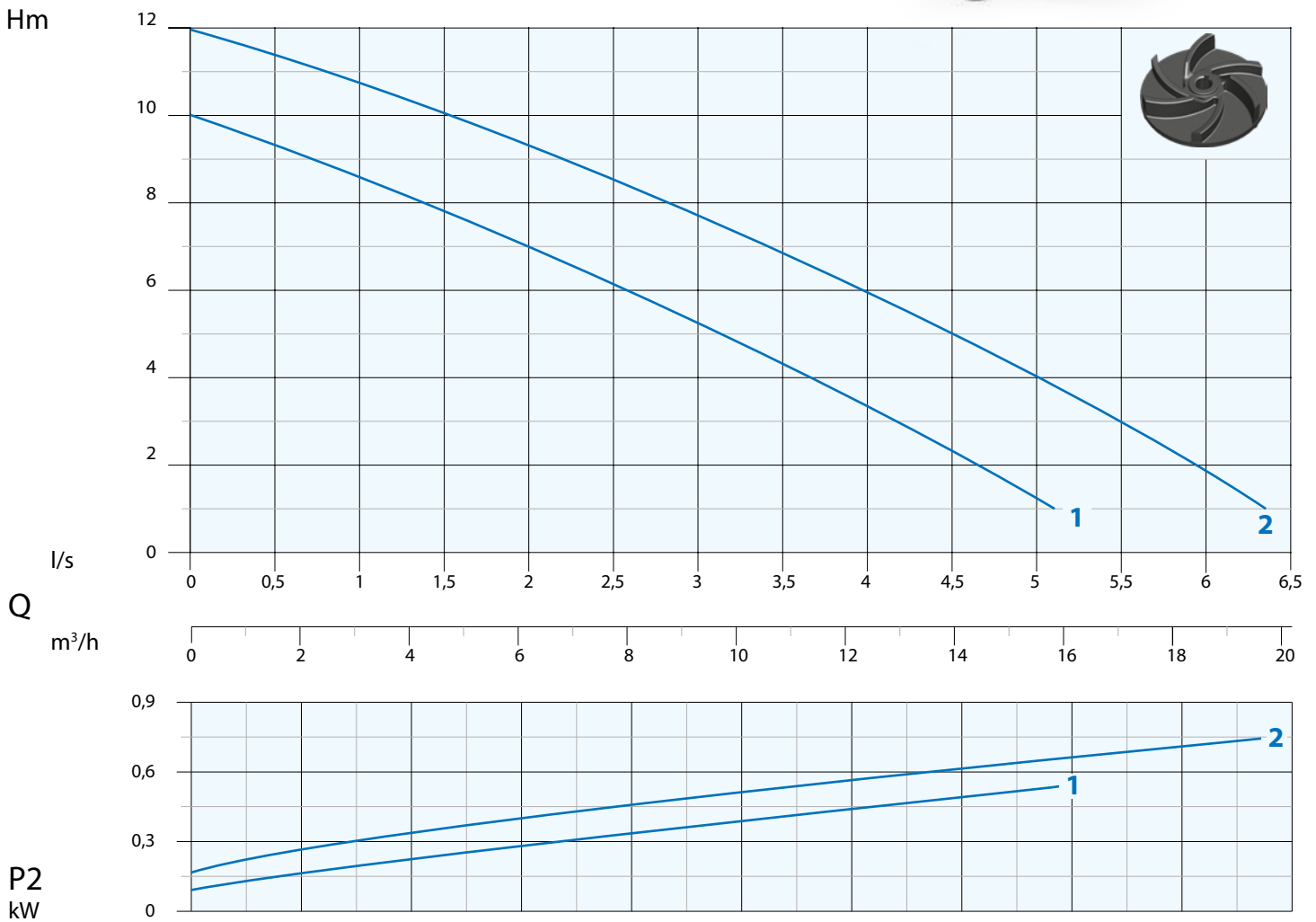

N°	Type	I/s	0,5	1	1,5	2	2,5	3	3,5	4	4,5	5	5,5	6
		l/m	30	60	90	120	150	180	210	240	270	300	330	360
		m³/h	1,8	3,6	5,4	7,2	9	10,8	12,6	14,4	16,2	18	19,8	21,6
1	Alpha V 2 M/T	mt	9,5	8,5	7,5	7	6	5,5	4,5	3,5	2,5	1		
2	Alpha V 3 M/T	mt	11,5	10,5	10	9,5	8,5	7,5	7	6	5	4	3	2

N°	Type	EVO	Delivery	Free Passage	kW			HP	R.P.M. 1/min	A		Hz
					P1	P2	1 Phase - 230V			µf	3 Phase - 400V	
1	Alpha V 2 M/T	•	G 1"1/2	35 mm	0,79	0,56	0,75	2850	4	16	2,1	50
2	Alpha V 3 M/T	•			1,1	0,75	1		5,3	20	2,3	

• Available EVO version

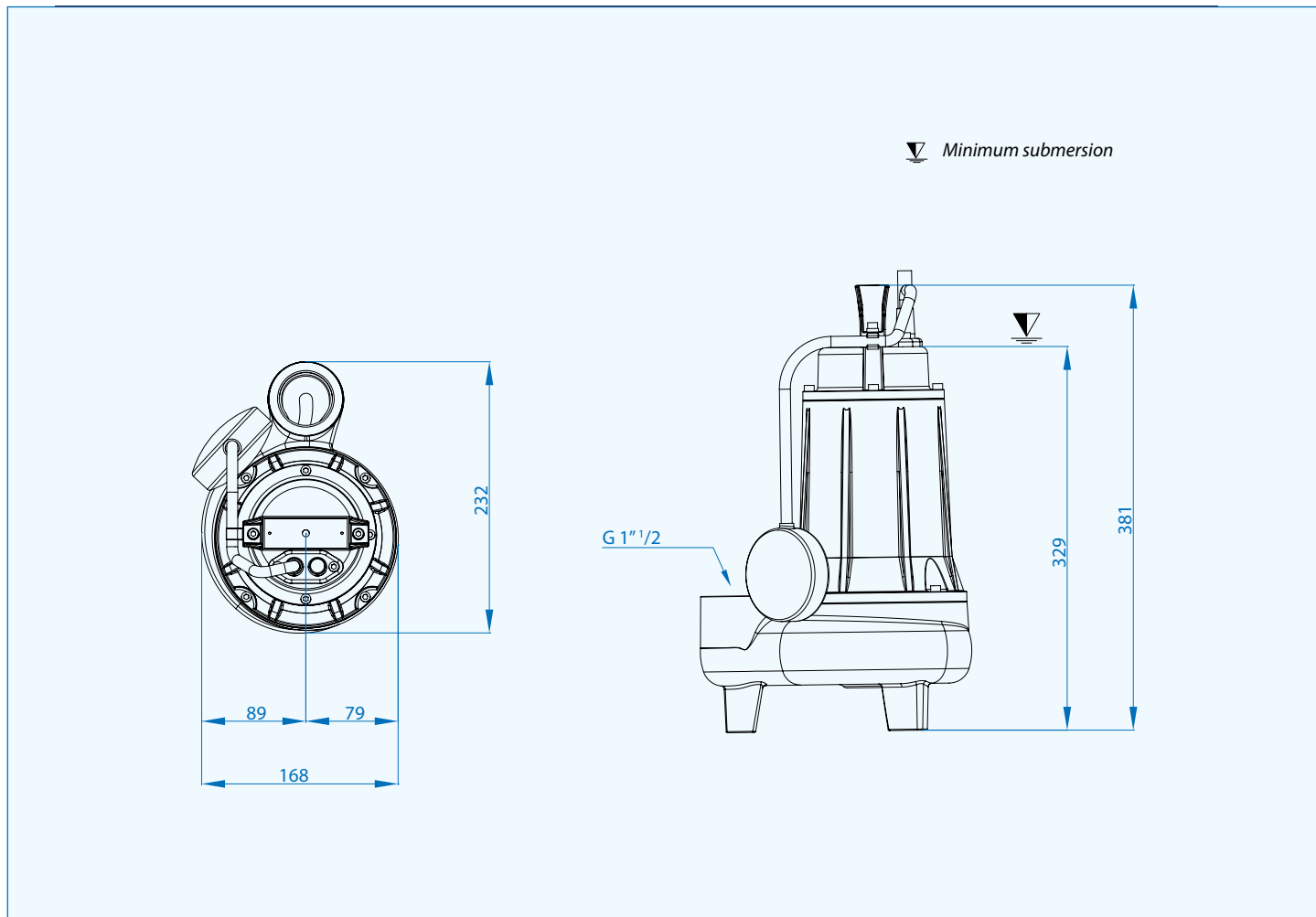

### Cables

Single phase 230V

H07RN8F 3x1 Ø9 Schuko plug Lunghezza - Length 10 mt

Threephase 400V

H07RN8F 4x1 Ø10 - Free terminals - Length 10 mt

### Optional



Hose connection 1"1/2



For single phase pumps: Control-box with external main capacitor

### Packaging dimension

Type	X mm	Y mm	Z mm	Kg
Alpha V 2 M/T	200	380	230	17,5
Alpha V 3 M/T				18



Vertical Outlet G 2" -  
RPM 2850 1/min 2 poles

Picture for illustration purposes only



### Performance Curve

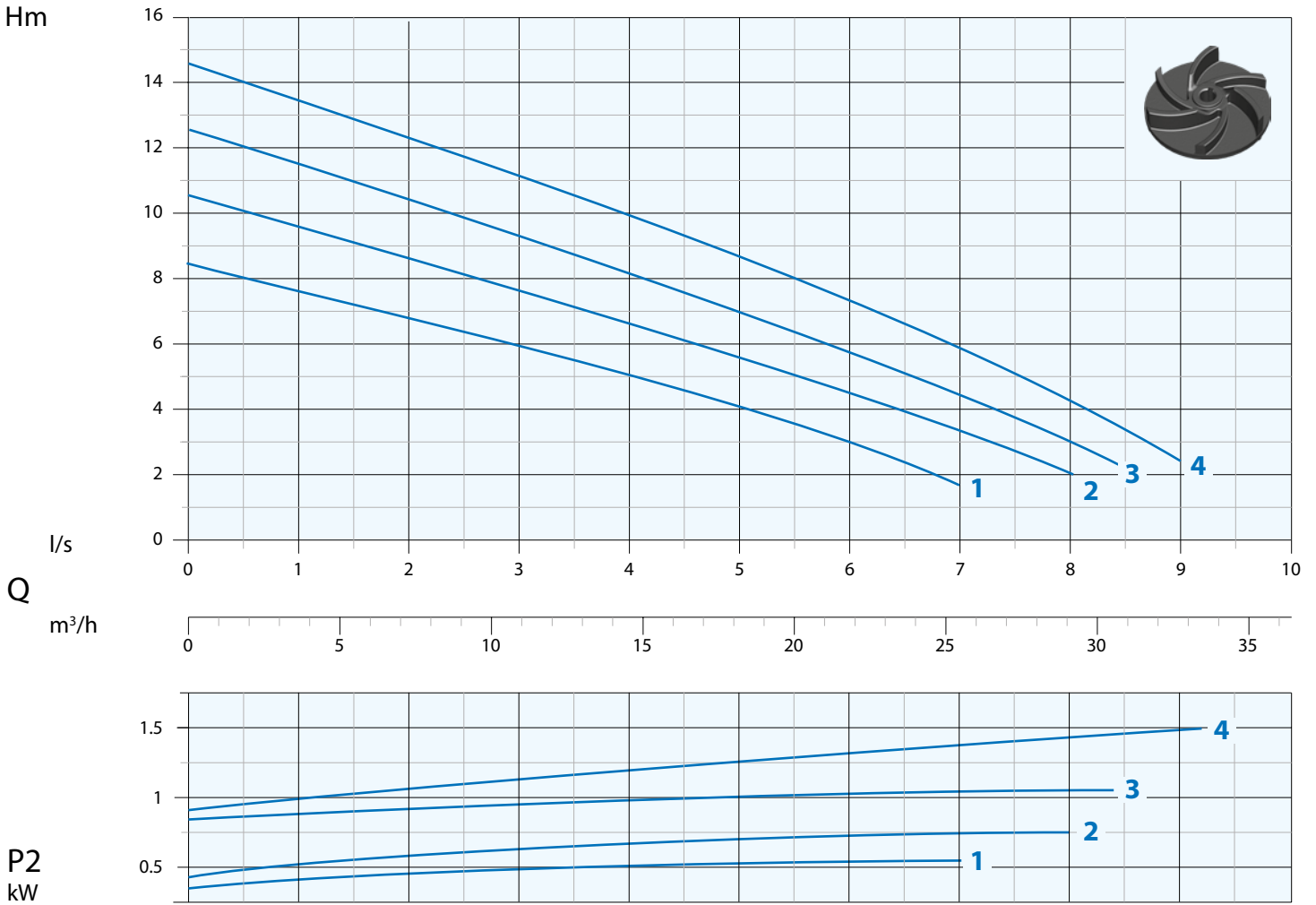

N°	Type	l/s	0,5	1	2	3	4	5	6	7	8	9
			l/m	30	60	120	180	240	300	360	420	480
		m³/h	1,8	3,6	7,2	10,8	14,4	18	21,6	25,2	28,8	32,4
1	Alpha V 22 M/T	mt	8	7,5	6,8	6	5	4	3	2		
2	Alpha V 32 M/T		10	9,5	8,5	7,5	6,5	5,5	4,5	3,5	2	
3	Alpha V 4 M/T		12	11,5	10,5	9,5	8	7	5,8	4,5	3	
4	Alpha V 55 M/T		14	13,5	12,5	11	10	8,5	7,5	6	4,2	2,5

N°	Type	EVO	Delivery	Free Passage	kW			R.P.M. 1/min	A			Hz
					P1	P2	HP		1 Phase - 230V	µf	3 Phase - 400V	
1	Alpha V 22 M/T	•	G 2"	40 mm	0,84	0,56	0,75	2850	3,9	16	2,1	50
2	Alpha V 32 M/T	•			1,1	0,75	1		4,9	20	2,3	
3	Alpha V 4 M/T	•		45 mm	1,5	1,1	1,5		7,6	30	2,9	
4	Alpha V 55 M/T	•			2,2	1,5	2		9,9	32	3,6	

• Available EVO version



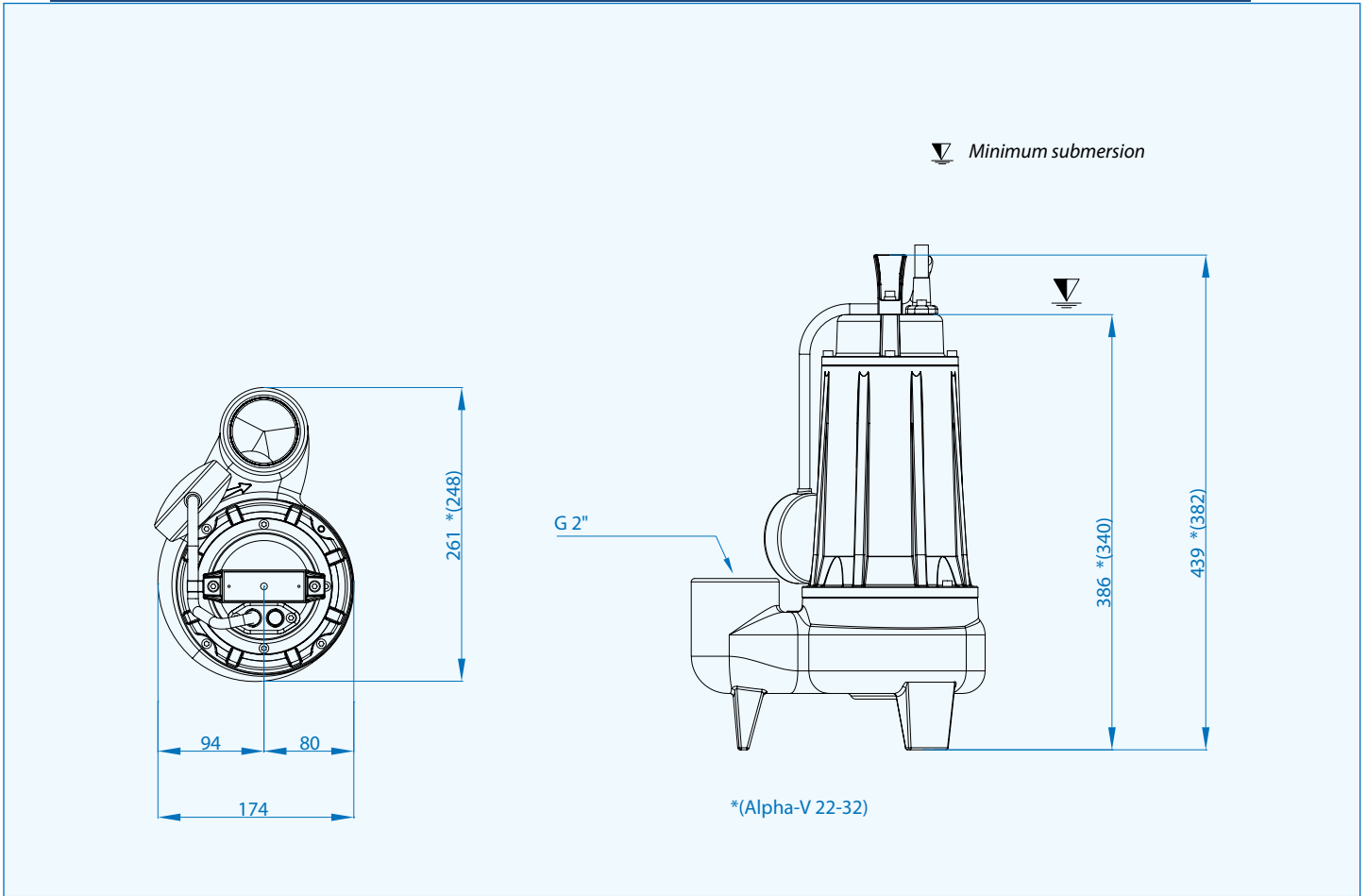

### Cables

Single phase 230V  
H07RN8F 3x1 Ø9 Schuko plug Length 10 mt

Threephase 400V  
H07RN8F 4x1 Ø10 Free terminals Length 10 mt

### Optional



Hose connection 2"



For single phase pumps: Control-box with external main capacitor

### Packaging dimension

Type	X mm	Y mm	Z mm	Kg
Alpha V 22 M/T	230	450	270	18
Alpha V 32 M/T				19
Alpha V 4 M/T				23
Alpha V 55 M/T				24



**List of components and materials**



**Technology and Features**



**Solids Handling**  
 Full free passage of solids.



**Explosion proof pumps**  
 Pumps with explosion proof available on request.

CE 0477  
 EPT 17 ATEX 2701 X

Ex II 2G  
 Ex db IIB T4 Gb  
 Ex h IIB T4 Gb  
 0° Ta ~ 40°



**Cable gland**  
 The cable gland is made of stainless steel AISI 316 and certified according to the norm ATEX EN 60079-0, EN 60079-1. Standard on all series.

Horizontal Outlet G 2"  
RPM 2850 1/min 2 poles

Picture for illustration purposes only



### Performance Curve

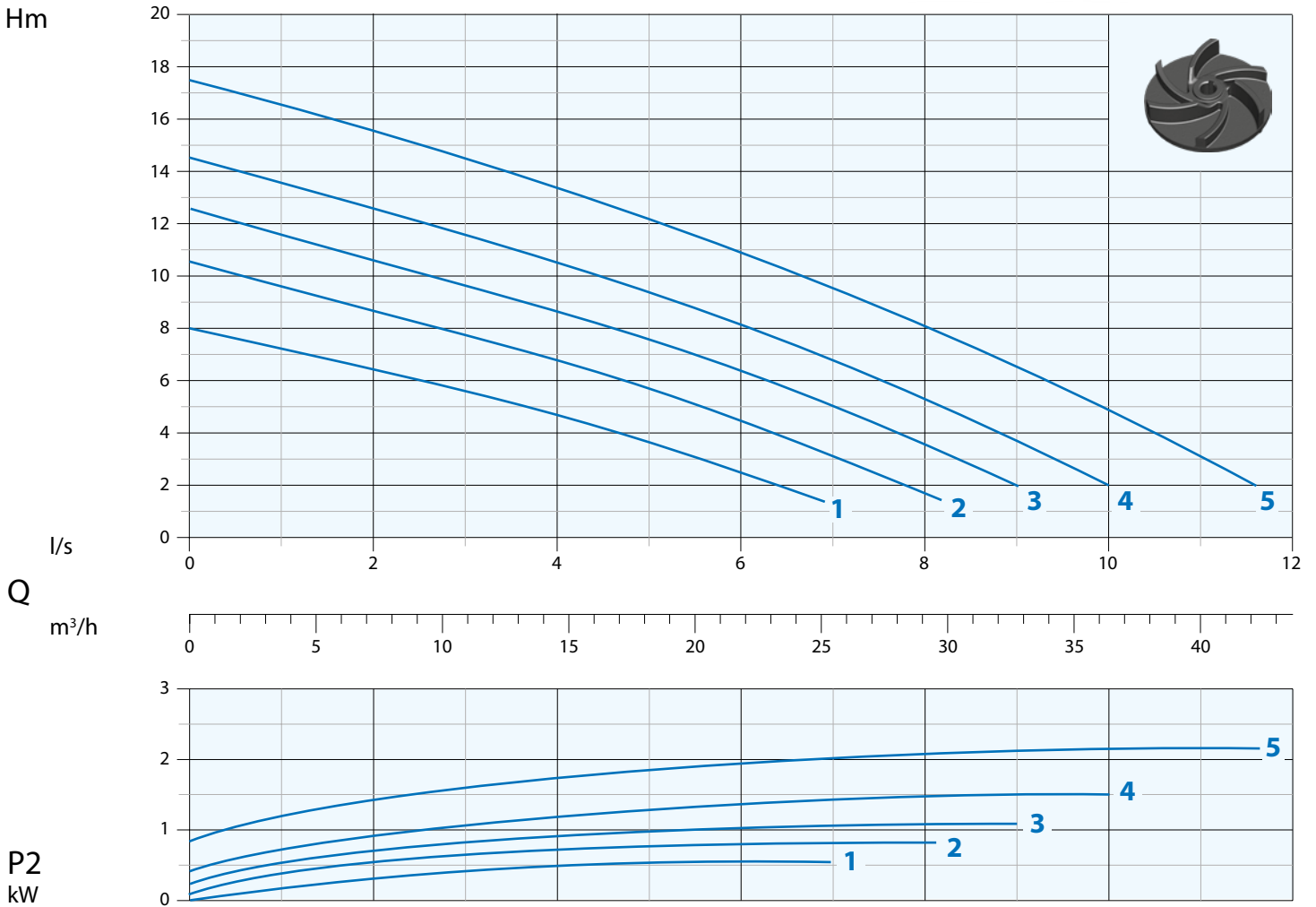

N°	Type	l/s l/m m³/h	1	2	3	4	5	6	7	8	10	11
			60	120	180	240	300	360	420	480	600	660
1	Alpha V PRO 50-2/060 M/T	mt	7	6,5	5,5	4,5	3,5	2,5	1			
2	Alpha V PRO 50-2/080 M/T		9,5	8,5	7,6	6,5	5,8	4,5	3	1,5		
3	Alpha V PRO 50-2/110 M/T		11,5	10,5	9,5	8,5	7,5	6,5	5	3,5		
4	Alpha V PRO 50-2/150 M/T		13,5	12,5	11,5	10,5	9,5	8	7	5,5	2	
5	Alpha V PRO 50-2/220 T		16,5	15,5	14,5	13,5	12,5	11	9,5	8	5	3

N°	Type	EX	Delivery	Free Passage	kW			R.P.M. 1/min	A		Hz
					P1	P2	HP		1 Phase - 230V	µf	
1	Alpha V PRO 50-2/060 M/T	•	G 2"	50 mm	0,9	0,6	0,8	2850	4,8	20	2,1
2	Alpha V PRO 50-2/080 M/T	•			1,1	0,8	1		6,0	25	2,4
3	Alpha V PRO 50-2/110 M/T	•			1,4	1,1	1,5		7,4	30	2,7
4	Alpha V PRO 50-2/150 M/T	•			2,0	1,5	2		9,6	40	3,7
5	Alpha V PRO 50-2/220 T	•			2,7	2,2	3				5,2

• Available explosion proof pump

CE 0477  
EPT 17 ATEX 2701 X

Ex II 2G Ex db IIB T4 Gb  
Ex h IIB T4 Gb  
0° Ta - 40°

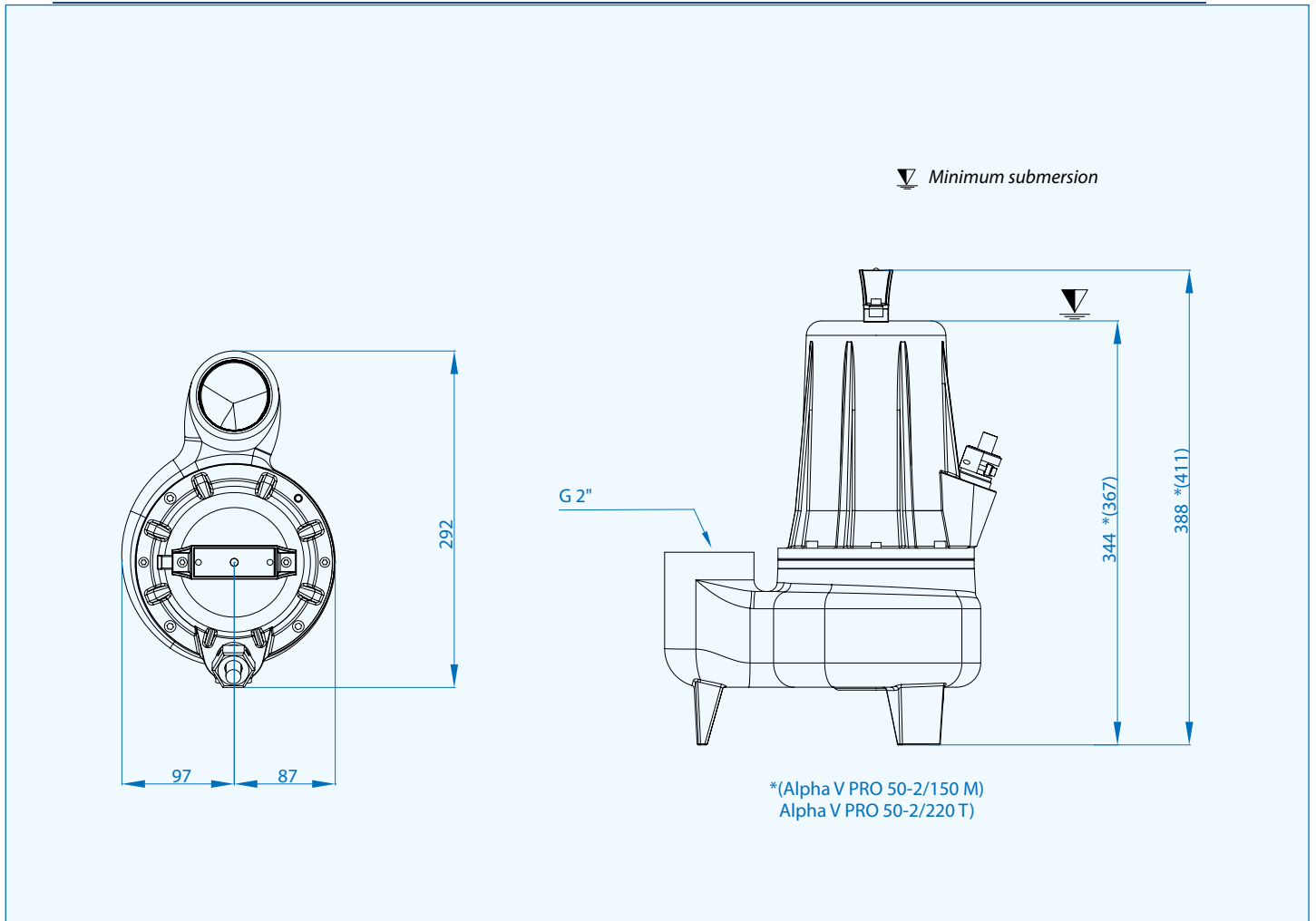

### Cables

Version	Phases	Cable	Cable cross section mm <sup>2</sup>	mt
Standard	1 ~ 230V	H07RN8F	4x1,5+2x0,50 Ø12*	10
	3 ~ 400V		4x1,5+2x0,50 Ø12**	10
Versioni/Versions ATEX	1 ~ 230V	NSSHÖU-J	4x1,5+2x0,50 Ø12*	10
	3 ~ 400V		4x1,5+2x0,50 Ø12**	10

\* Standard with Control-box \*\* Free terminals

### Optional



Hose connection 2"



Explosion proof control box available on request

### Packaging dimension

Type	X mm	Y mm	Z mm	Kg
Alpha V PRO 50-2/060	230	450	270	25,5
Alpha V PRO 50-2/080				25,5
Alpha V PRO 50-2/110				25,5
Alpha V PRO 50-2/150				25,5
Alpha V PRO 50-2/220				28

## Submersible electropumps with Vortex impeller

Power:	0.9÷2.2 kW
Delivery:	DN50 - 65 - 80



### Application

The DNA Series is used for sewage and waste water. Its wide channel permits the free passage of solids rendering it particularly useful in water treatment plants, domestic, municipal and farming applications. The 4 pole version can be used in applications where continuous S1 service is needed and are characterised by their quiet operation.

### Characteristic

The main components are fabricated in cast iron GG20. The Double mechanical seal in a back to back configuration located in the oil chamber guarantee long durability to the product.

### Motor range

- Squirrel cage motor in 2 poles version
- Thermal protection embedded in the winding (In the DNA ...-2/220 and DNA ...-4/090 model the thermal protection T1 and T2 conductor to be wired to the control panel)
- Insulation class F 155°C
- Motor protection IP 68

### Motor cooling

The cooling of the motor is ensured by the liquid where the pump is submerged.

### Limits of use

- Max. permissible liquid temperature: 40°C with pump fully submerged
- Maximum depth of immersion: 20 mt.
- Permissible pH value: 6-10
- Hydraulic features suitable for liquids with density <math>< 1,1 \text{ kg/dm}^3</math>
- Allowed voltage: 230V/400V  $\pm 5\%$
- Allowed frequency: 50Hz  $\pm 2\%$

### Designation

**DNA EX 80 - 2 / 150 M/T G**

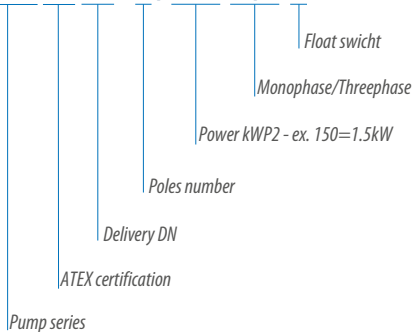

### Performance Overview

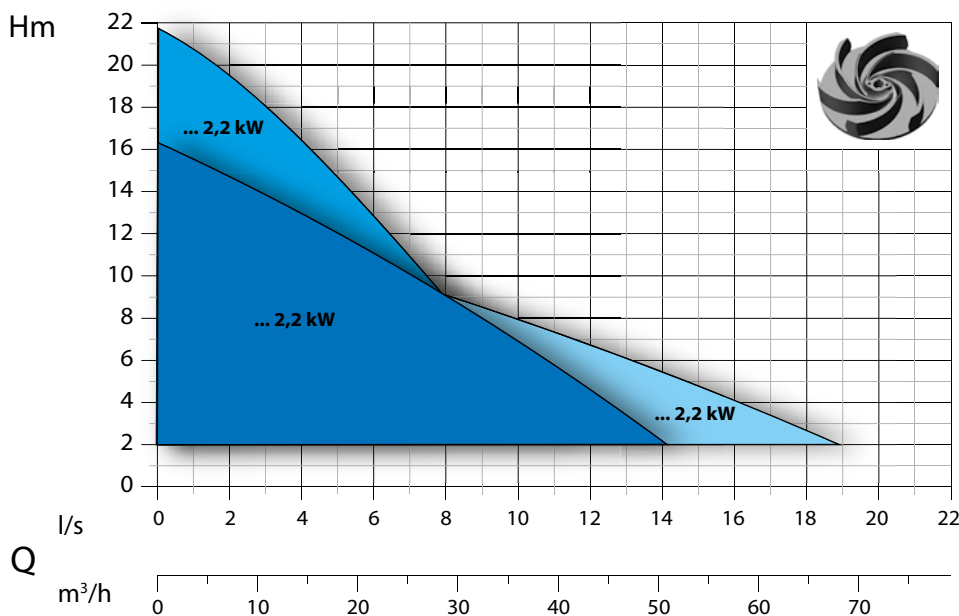

### Curves Identification

- DN50
- DN65
- DN80

### Norms

According to ISO 9906:2012 3B2

## List of components and materials

Handle  
Stainless steel

Motor Cover  
Cast Iron GG20

Motor Casing  
Cast Iron GG20

Motor Shaft  
Stainless steel AISI 420

Electric Motor  
-

Flange Bearing Support  
Cast Iron GG20

Double Mechanical Seal  
Motor side: Carbon/Ceramic (CA/CE/Viton)  
Impeller side: Silicon carbide (SIC/SIC/Viton)

ATEX Configuration  
Motor side: Lip seal  
Impeller side: Silicon carbide (SIC/SIC/Viton)

Impeller  
Cast Iron GG20

Body Pump  
Cast Iron GG20

Wearing Plate  
Cast Iron GG20

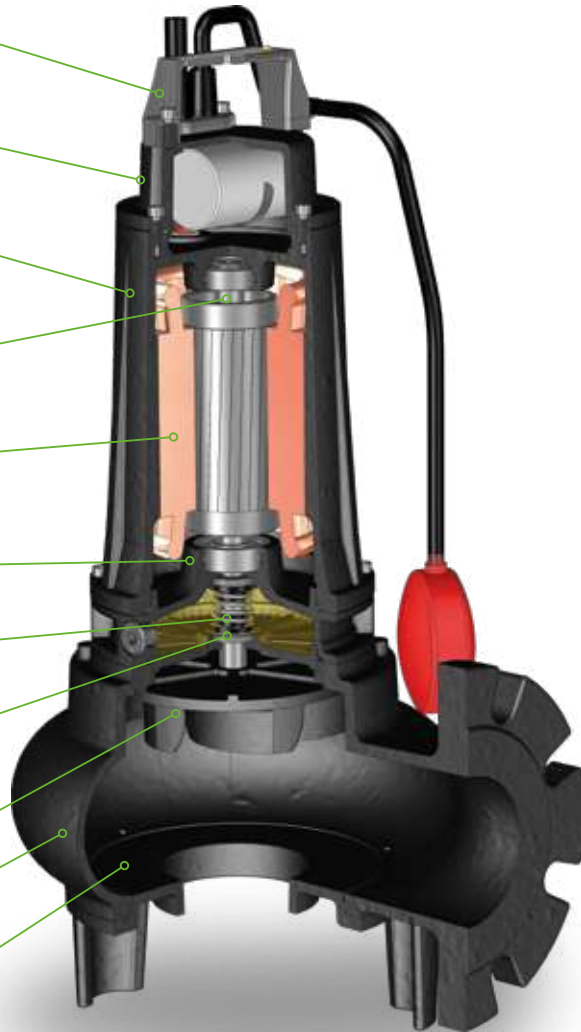

## Technology and Features



**Explosion proof pumps**  
Pumps with explosion proof available on request.



**Relay**  
For the correct operating of the float switch on the three-phase version, up to 1,5 kW 2 poles. ATEX excluded.

CE 0477  
EPT 17 ATEX 2701 X

Ex II 2G Ex db IIB T4 Gb  
Ex h IIB T4 Gb  
0°~ Ta ~ 40°



**Solids Handling**  
Full free passage of solids.



**Oil Chamber**  
Excellent lubrication of the mechanical seals even in the harshest pumping conditions. Inspectional oil chamber.

### Horizontal Outlet DN50 PN10 - G 2" - RPM 2850 1/min 2 poles

Picture for illustration purposes only



### Performance Curve

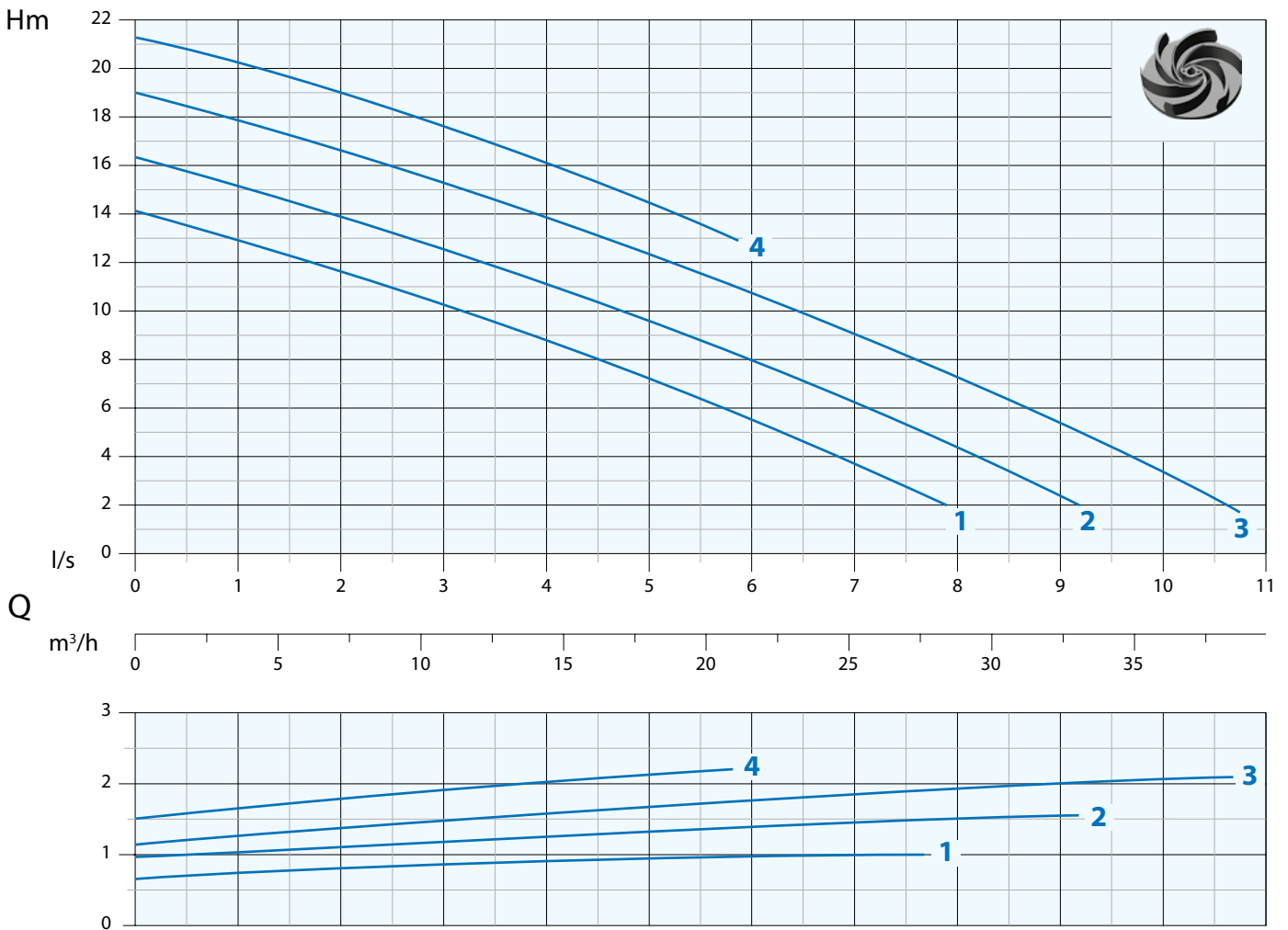

N°	Type		l/s	0,5	1	2	3	4	5	6	7	8	9	10
			l/m	30	60	120	180	240	300	360	420	480	540	600
		m³/h	1,8	3,6	7,2	10,8	14,4	18	21,6	25,2	28,8	32,4	36	
1	DNA 50-2/110 M/T	mt	13,5	13	11,5	10,5	8,8	7	5,5	3,5	2			
2	DNA 50-2/150 M/T		15,8	15	14	12,5	11	9,5	8	6,5	4,5	2,5		
3	DNA 50-2/220 T		18,5	18	16,5	15,2	14	12,5	10,8	9	7,2	5,5	3,5	
4	DNA 50-2/220-1 T		20,8	20	19	17,5	16	14,5						

N°	Type	EX	Delivery	Free Passage	kW			HP	R.P.M. 1/min	A		Hz
					P1	P2				1 Phase - 230V	µf	
1	DNA 50-2/110 M/T	•	DN50 PN10 - G 2"	50 mm	1,6	1,1	1,5	2850	7,8	30	2,9	50
2	DNA 50-2/150 M/T	•			2,1	1,5	2		9,9	32	3,6	
3	DNA 50-2/220 T	•			3,0	2,2	3				5,3	
4	DNA 50-2/220-1 T	•			3,0	2,2	3				5,3	

• Available explosion proof pump

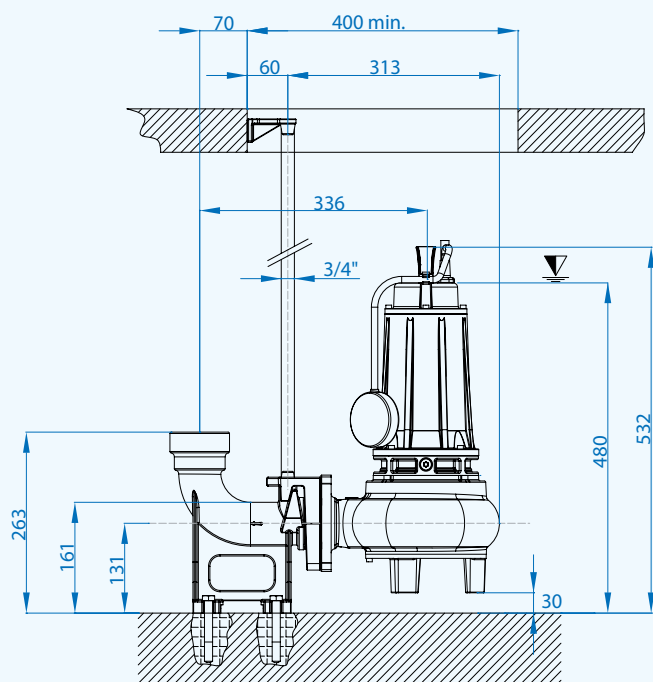

\*DNA(EX) 50-2/220 - \*DNA(EX) 50-2/220-1  
 \*\*VERSIONI ATEX ýno a 1,5kW - \*\*ATEX VERSION up to 1,5kW

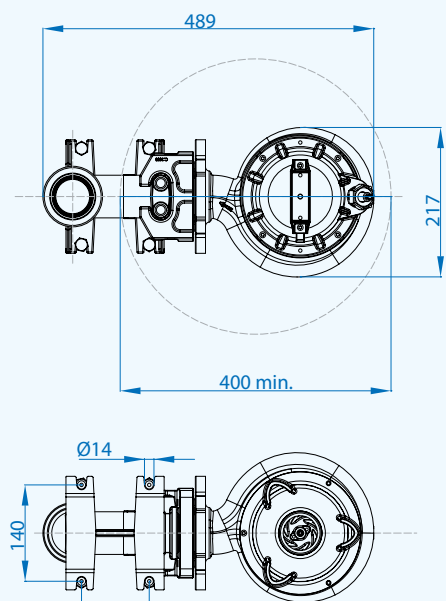
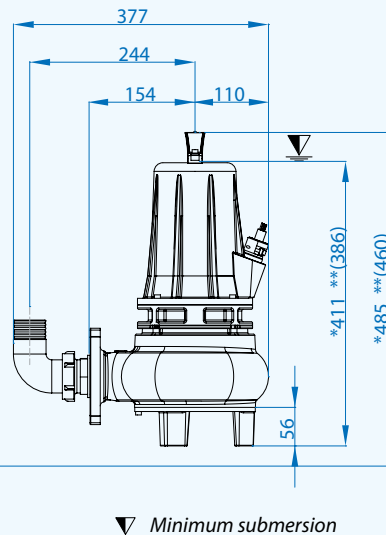

\*(DN50 PN10  
 ex UNI 2278  
 G 2")

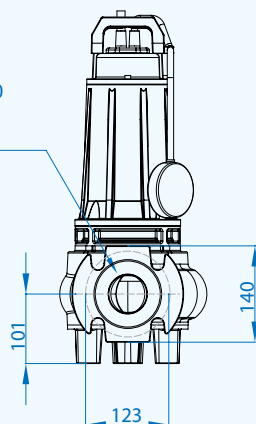

### Cables

Pumps	Phases	Cable	Cable cross section mm <sup>2</sup>	mt
DNA 50-2/110-150	1 ~ 230V	H07RN8F	3x1 Ø9*	10
	3 ~ 400V		4x1 Ø10**	10
DNA 50-2/220-220-1	3 ~ 400V	H07RN8F	4x1,5+2x0,50 Ø12**	10
Versioni /Versions ATEX	1 ~ 230V	NSSHÖU-J	4x1,5+2x0,50 Ø12***	10
	3 ~ 400V		4x1,5+2x0,50 Ø12**	10

\* Schuko plug

\*\* Free terminals \*\*\* Standard with control-box

### Packaging dimension

Type	X mm	Y mm	Z mm	Kg
DNA 50-2/110 M/T	260	585	315	28
DNA 50-2/150 M/T				29
DNA 50-2/220 T				30
DNA 50-2/220-1 T				30

### Optional

Explosion proof control box available on request



For single phase pumps:  
 Control-box with external  
 main capacitor

Automatic coupling foot  
 Type: DUTY 50 Easy 3.2 or E3.1

Thread hose  
 connection 2"



Horizontal Outlet DN50 PN10 - G 2" -  
RPM 1450 1/min 4 poles

Picture for illustration purposes only



### Performance Curve

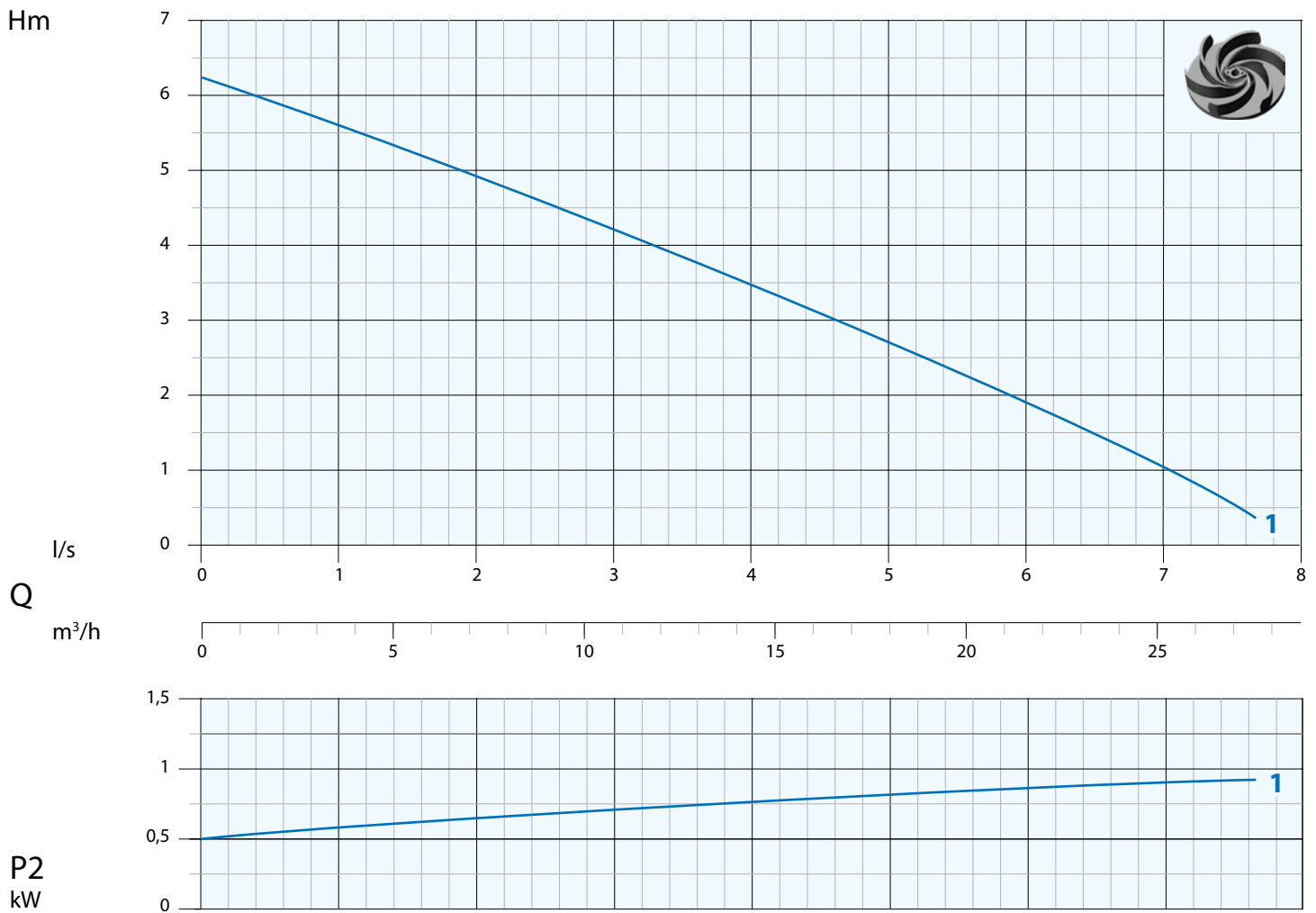

N°	Type	l/s	0,5	1	2	3	4	5	6	7	7,5
		l/m	30	60	120	180	240	300	360	420	450
		m³/h	1,8	3,6	7,2	10,8	14,4	18	21,6	25,2	27
1	DNA 50-4/090 M/T	mt	5,8	5,2	4,8	4,5	3,5	2,7	1,8	1	0,5

N°	Type	EX	Delivery	Free Passage	kW		HP	R.P.M. 1/min	A			Hz
					P1	P2			1 Phase - 230V	µf	3 Phase - 400V	
1	DNA 50-4/090 M/T	•	DN50 PN10 - G 2"	50 mm	1,1	0,9	1,2	1450	4,7	20	2,5	50

• Available explosion proof pump



Ex db IIB T4 Gb  
Ex h IIB T4 Gb  
0° Ta + 40°

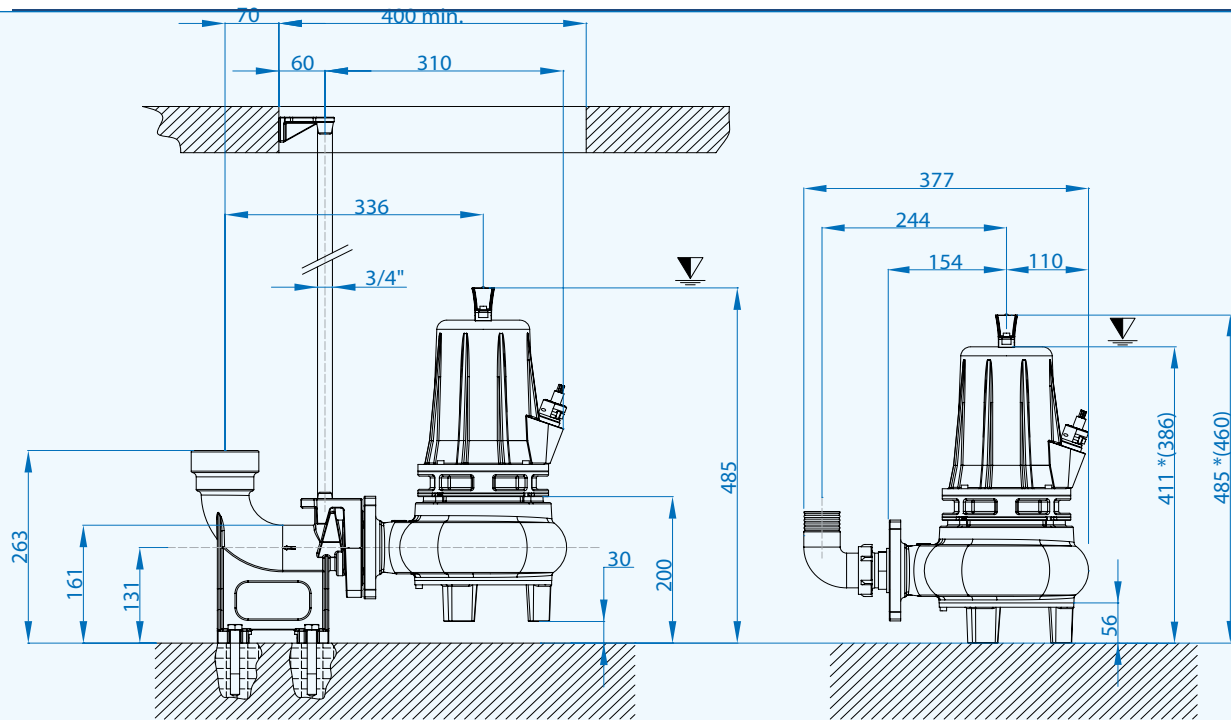

\* VERSIONI ATEX - ATEX VERSION

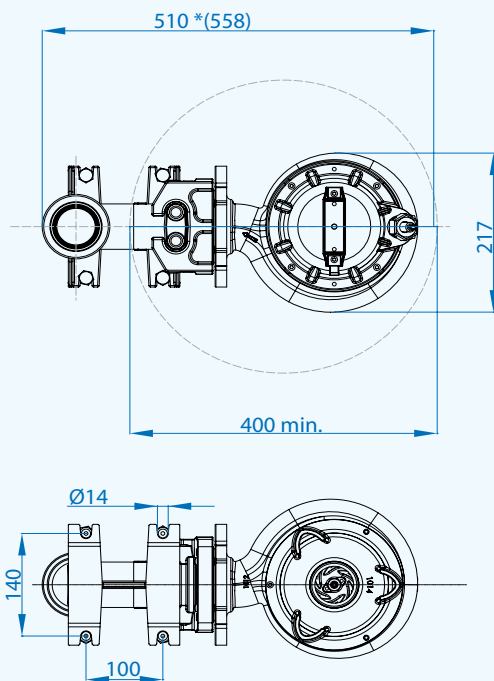

Minimum submersion

(DN50 PN10  
ex UNI 2278  
G 2")

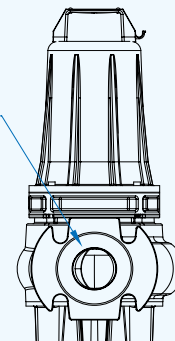

### Cables

	Phases	Cable	Cable cross section mm <sup>2</sup>	mt
Standard	1 ~ 230V	H07RN8F	4x1,5+2x0,50 Ø12*	10
	3 ~ 400V		4x1,5+2x0,50 Ø12**	10
Versioni - Versions ATEX	1 ~ 230V	NSSHÖU-J	4x1,5+2x0,50 Ø12*	10
	3 ~ 400V		4x1,5+2x0,50 Ø12**	10

\* Standard with Control Box \*\* Free terminals

### Packaging dimension

Type	X mm	Y mm	Z mm	Kg
DNA 50-4/090 M/T	260	585	315	30

### Optional



Explosion proof control box available on request



Automatic coupling foot  
Type: DUTY 50 Easy 3.2 or Easy 3.1



Thread hose connection 2"

### Horizontal Outlet DN65 PN10 - RPM 2850 1/min 2 poles

Picture for illustration purposes only



### Performance Curve

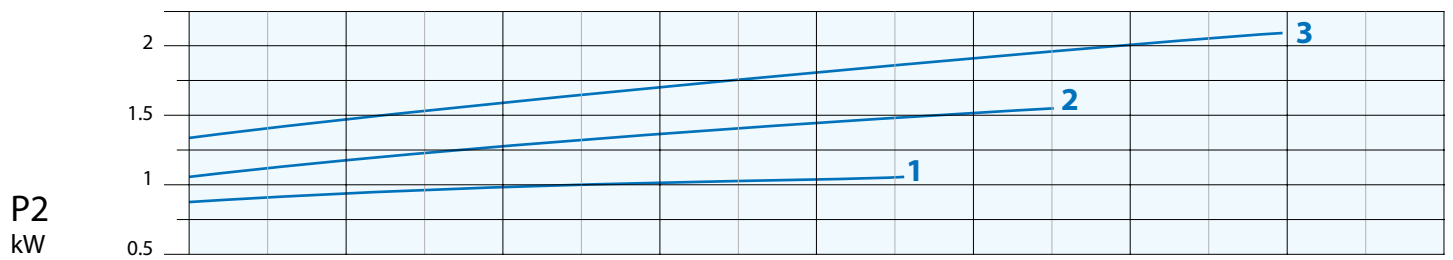
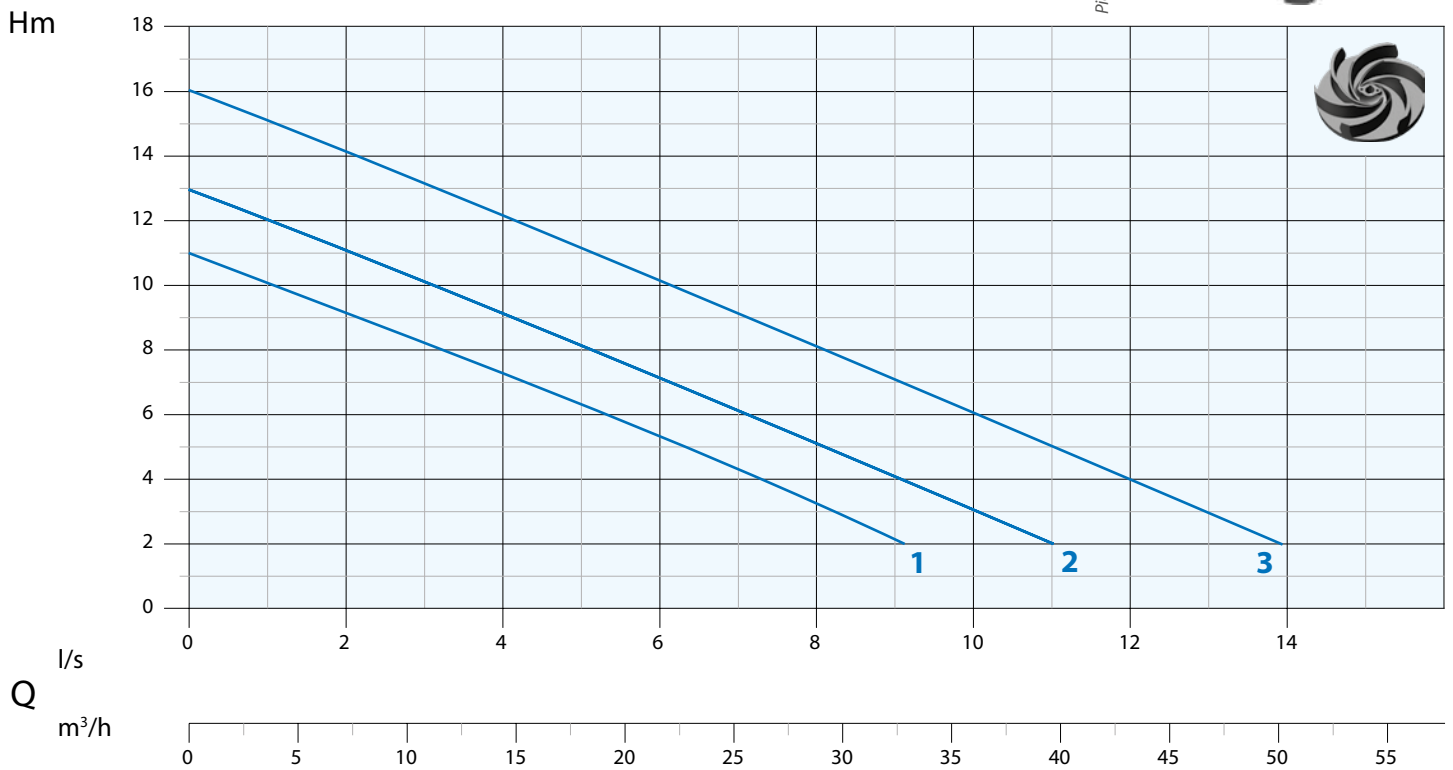

N°	Type	l/s	1	2	4	6	8	10	11	12	14
		m³/h	3,6	7,2	14,4	21,6	28,8	36,0	39,6	43,2	50,4
1	DNA 65-2/110 M/T	mt	10	9	7,5	5,5	3,2				
2	DNA 65-2/150 M/T		12	11	9	7	5	3	2		
3	DNA 65-2/220 T		15	14	12	10	8	6	5	4	2

N°	Type	EX	Delivery	Free Passage	kW			R.P.M. 1/min	A		Hz
					P1	P2	HP		1 Phase - 230V	µf	
1	DNA 65-2/110 M/T	•	DN65 PN10	65 mm	1,6	1,1	1,5	2850	7,4	30	2,7
2	DNA 65-2/150 M/T	•			1,9	1,5	2		9,9	32	3,4
3	DNA 65-2/220 T	•			2,6	2,2	3				5,2

• Available explosion proof pump

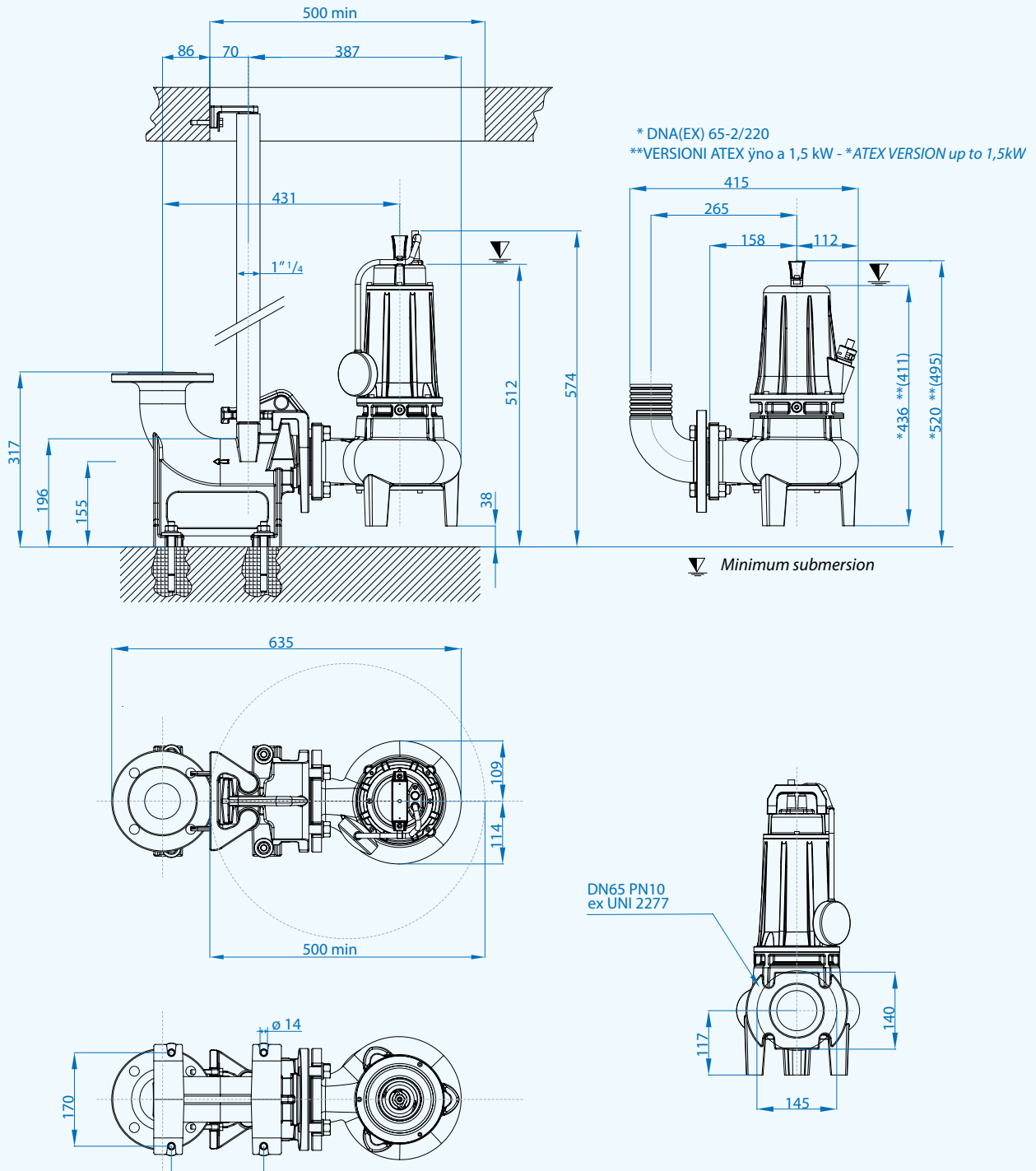

### Cables

Pumps	Phases	Cable	Cable cross section mm <sup>2</sup>	mt
DNA 65-2/110-150	1 ~ 230V	H07RN8F	3x1 Ø9*	10
	3 ~ 400V	H07RN8F	4x1 Ø10**	10
DNA 65-2/220 T	3 ~ 400V	H07RN8F	4x1,5+2x0,50 Ø12**	10
Versions ATEX	1 ~ 230V	NSSHÖU-J	4x1,5+2x0,50 Ø12***	10
	3 ~ 400V	NSSHÖU-J	4x1,5+2x0,50 Ø12**	10

\* Schuko plug

\*\* Free terminals \*\*\* Standard with control-box

### Packaging dimension

Type	X mm	Y mm	Z mm	Kg
DNA 65-2/110 M/T				28
DNA 65-2/150 M/T	260	585	315	30
DNA 65-2/220 T				30,5

### Optional



Explosion proof control box available on request



For single phase pumps:  
Control-box with external  
main capacitor



Automatic coupling foot  
Type: DUTY 65



Flanged hose connection N5

Horizontal Outlet DN80 PN16  
 RPM 2850 1/min 2 poles RPM  
 1450 1/min 4 poles

Picture for illustration purposes only



### Performance Curve

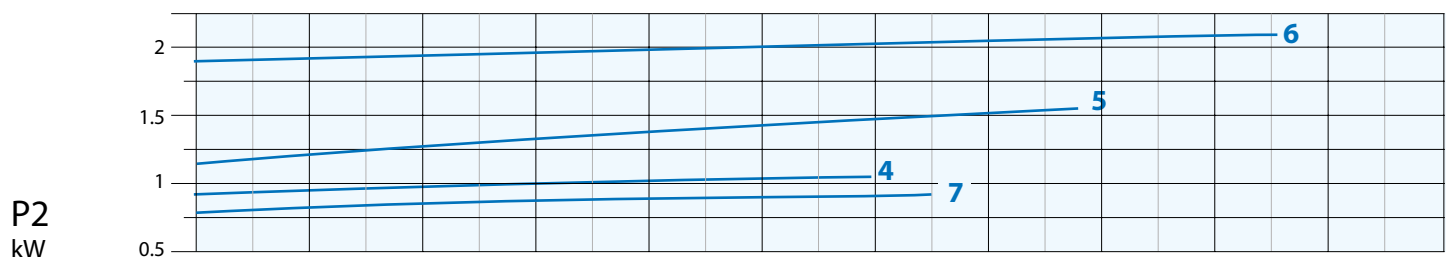
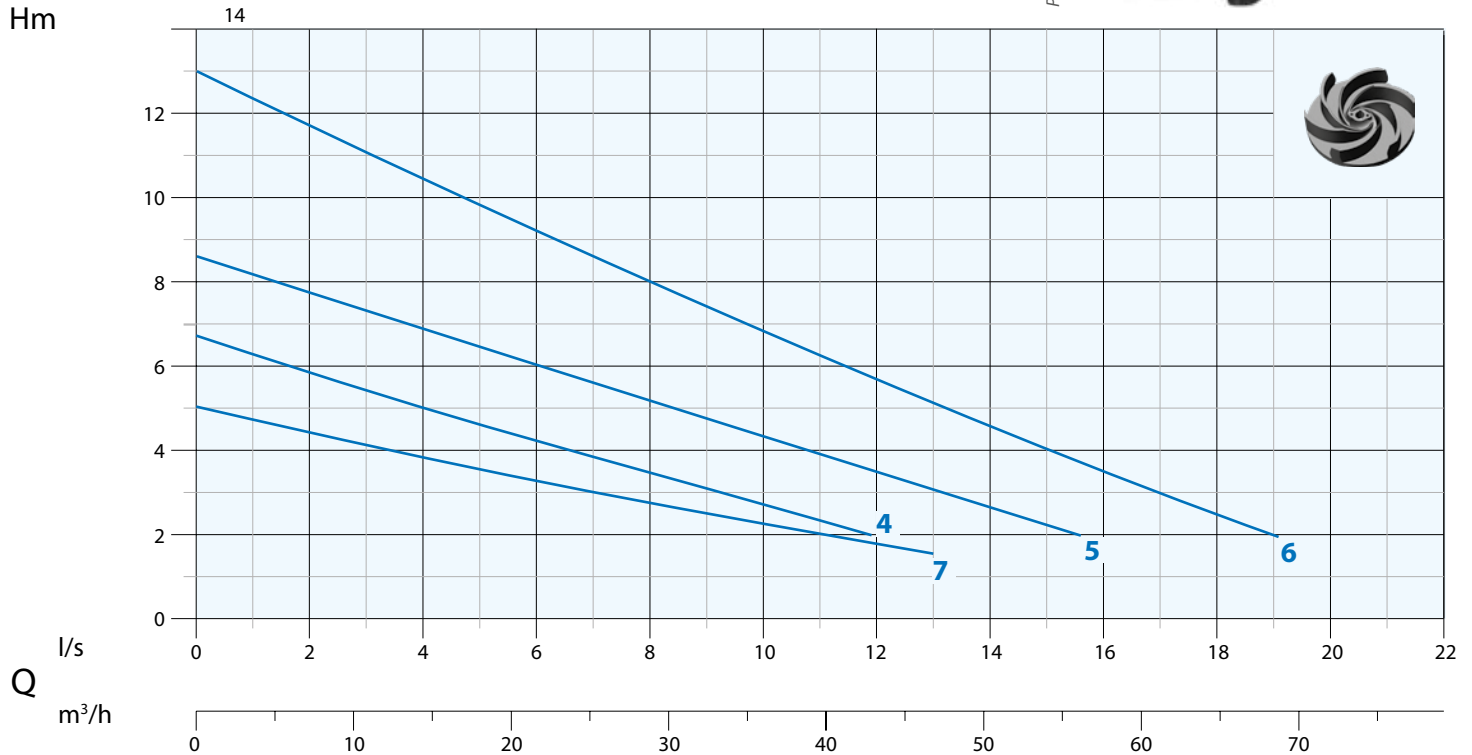

N°	Type	l/s										
			1	2	4	6	8	10	12	14	16	
			l/m	60	120	140	360	480	600	720	840	960
		m³/h	3,6	7,2	14,4	21,6	28,8	36,0	43,2	50,4	57,6	
4	DNA 80-2/110 M/T	mt	6,5	5,8	5	4,5	3,5	2,8	2			
5	DNA 80-2/150 M/T		8,2	7,5	7	6	5,3	4,5	3,5	2,5		
6	DNA 80-2/220 T		12,5	11,5	10,5	9,2	8	6,8	5,8	4,5	3,5	
7	DNA 80-4/090 M/T		4,8	4,5	3,9	3,2	2,8	2,5	1,8			

N°	Type	EX	Delivery	Free Passage	kW			R.P.M. 1/min	A			Hz
					P1	P2	HP		1 Phase - 230V	µf	3 Phase - 400V	
4	DNA 80-2/110 M/T	•	DN80 PN16	80 mm	1,6	1,1	1,5	2850	7,4	30	2,8	50
5	DNA 80-2/150 M/T	•			1,9	1,5	2		9,9	32	3,6	
6	DNA 80-2/220 T	•			2,7	2,2	3				5,3	
7	DNA 80-4/090 M/T	•			75 mm	1,1	0,9	1,2	1450	4,7	20	

• Available explosion proof pump

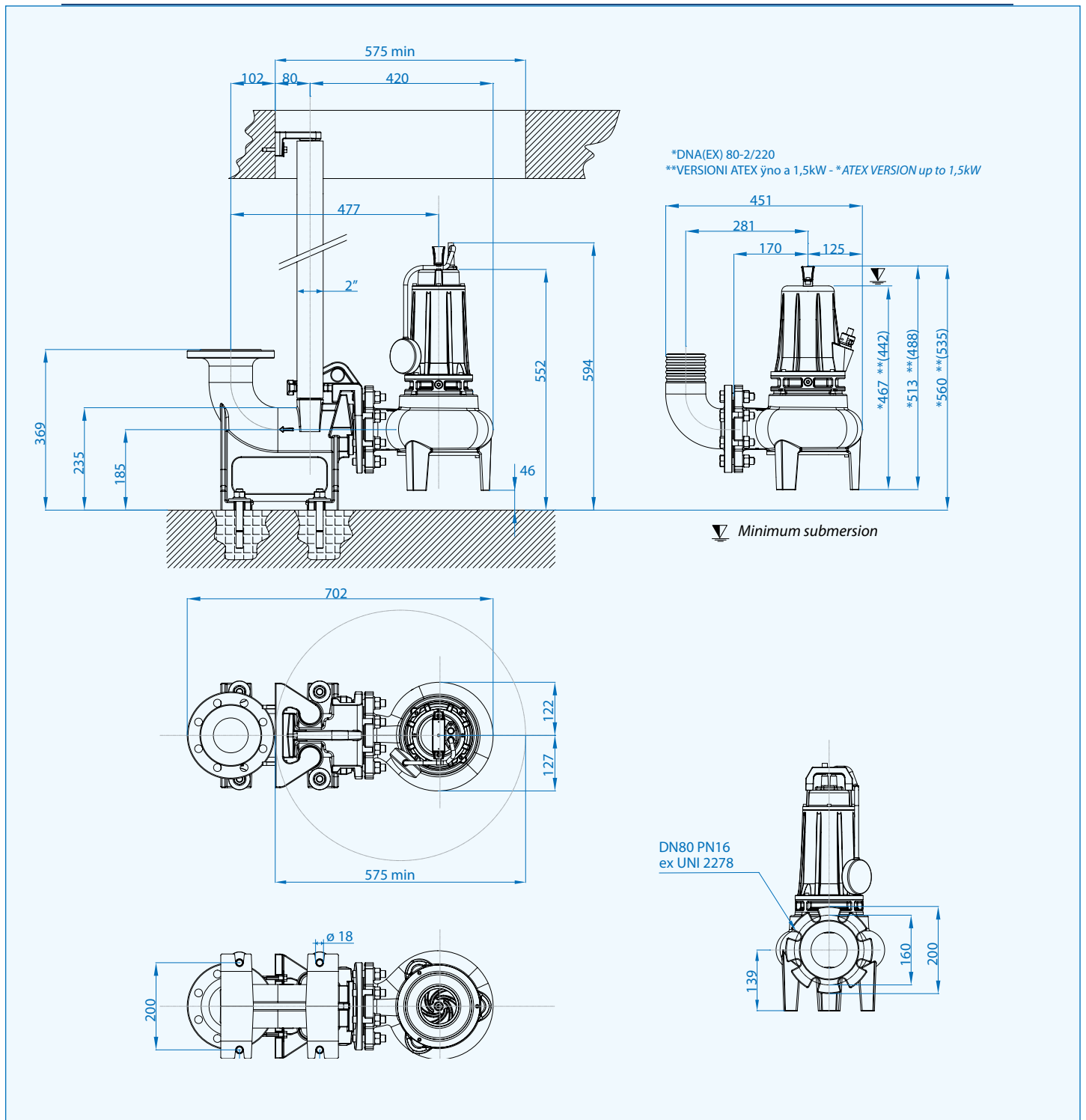

## Cables

Pumps	Phases	Cable	Cable cross section mm <sup>2</sup>	mt
DNA 80-2/110/150	1 ~ 230V	H07RN8F	3x1 Ø9*	10
	3 ~ 400V	H07RN8F	4x1 Ø10**	10
DNA 80-2/220	3 ~ 400V	H07RN8F	4x1,5+2x0,50 Ø12**	10
	1 ~ 230V	H07RN8F	4x1,5+2x0,50 Ø12***	10
DNA 80-4/090	3 ~ 400V	H07RN8F	4x1,5+2x0,50 Ø12**	10
	1 ~ 230V	H07RN8F	4x1,5+2x0,50 Ø12***	10
Versioni/Version ATEX	1 ~ 230V	NSSHÖU-J	4x1,5+2x0,50 Ø12***	10
	3 ~ 400V	NSSHÖU-J	4x1,5+2x0,50 Ø12**	10

\* Schuko plug

\*\* Free terminals \*\*\* Standard with control-box

## Packaging dimension

Type	X mm	Y mm	Z mm	Kg
DNA 80-2/110 M/T	260	585	315	32
DNA 80-2/150 M/T				34,5
DNA 80-2/220 T				35
DNA 80-4/090 M/T				38

## Optional



Explosion proof control box available on request



For single phase pumps:  
Control-box with external main capacitor

Automatic coupling foot  
Type: DUTY 80 and B5

Flanged hose connection N2

### Submersible electropumps with Vortex impeller

Power:	<b>1.5÷9 kW</b>
Delivery	<b>DN65 - 80</b>



#### Application

The V 2 poles Series is used for pumping sewage with suspended solids. High performance renders it useful in a variety of applications including water treatment plants, industrial plants, farming and sewage.

#### Characteristic

All main components are made of grey cast iron GG25. Two individual mechanical seals (motor side in the oil chamber, impeller side in contact with the liquid) and high quality parts, ensure the perfect functioning and reliability of the product.

#### Motor range

- Squirrel cage motor in 2 poles version
- Thermal protection T1 and T2 embedded in the motor winding (to be wired to the three pole contactor in the control panel)
- Class F insulation (155°C)
- IP 68 protection

#### Motor cooling

The cooling of the motor is ensured by the liquid where the pump is submerged.

#### Limits of use

- Max. permissible liquid temperature: 40°C with pump fully submerged
- On request, special version (excluded ATEX) to withstand liquid temperature up to 60°C with pump fully submerged, no S1 service
- Maximum depth of immersion: 20 mt.
- Permissible pH value: 6-10
- Hydraulic features suitable for liquids with density <math>< 1,1 \text{ kg/dm}^3</math>
- Allowed voltage: 230V/400V - 400V-690V  $\pm 5\%$
- Allowed frequency: 50Hz  $\pm 2\%$

#### Designazione / Designation

**VT-EX 80 / 2 / 173 C.354**

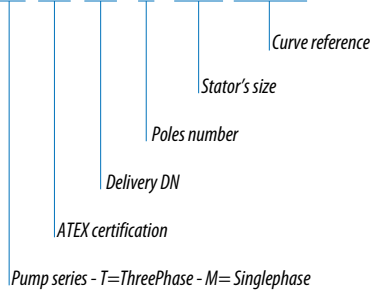

#### Performance Overview

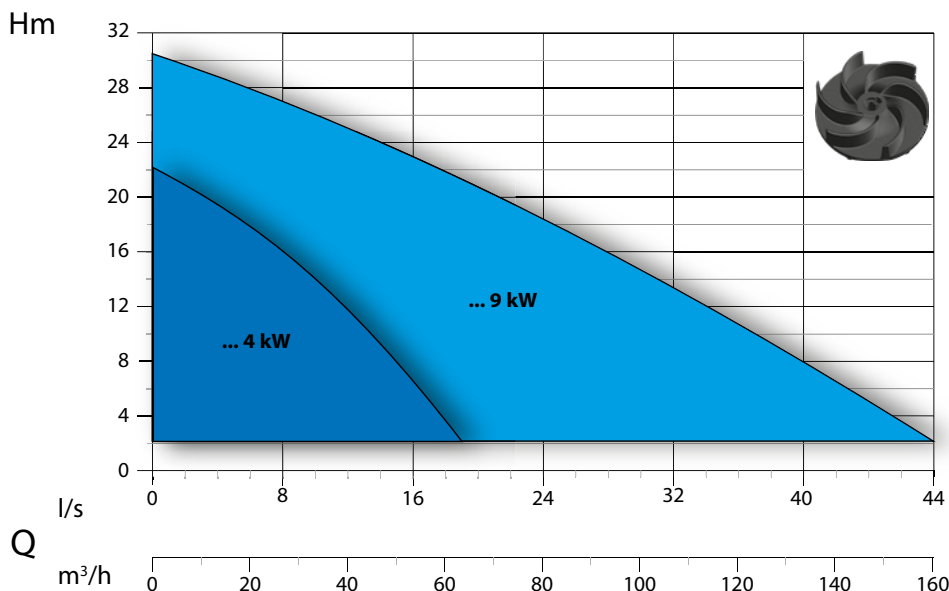

#### Curves Identification

- DN65
- DN80

#### Norms

According to ISO 9906:2012 3B2

## List of components and materials

Chain ring

Stainless steel AISI 416

Motor casing

Cast iron GG25

Upper bearing

Motor shaft Stainless

steel AISI 420

Electric motor

Rotor

Lower bearing

Motor holder

Cast iron GG25

Mechanical seal

Carbon/Ceramic (CA/CE/Viton)

Motor holder

Cast iron GG25

Mechanical seal

Silicon/Carbide (SIC/SIC/Viton)

Body pump

Cast iron GG25

Impeller

Cast iron GG25

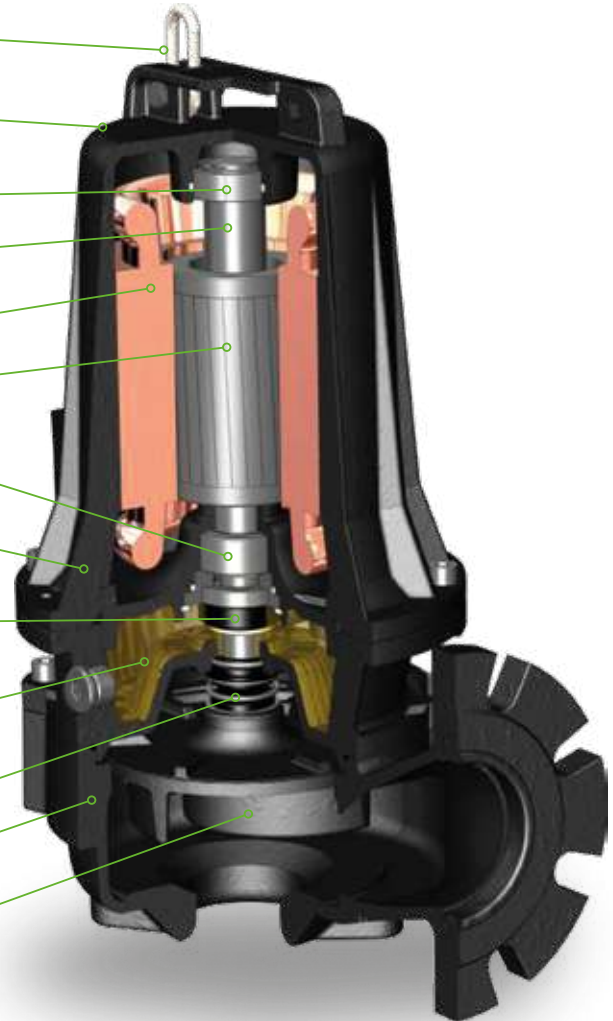

## Technological Features

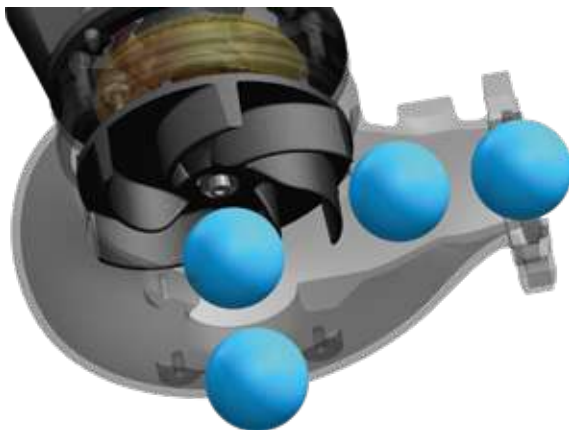

### Impellers

Impellers have been studied to grant excellent performances and ample solid handling.



### Explosion proof pumps



Ex db IIB T4 Gb  
Ex h IIB T4 Gb  
0°~ Ta ~ 40°

EPT 17 ATEX 2702 X

Pumps with explosion proof available on request.



### Seal leak detector

The seal leak detector is certified according to the norm ATEX EN 60079-0, EN 60079-1 (through safety barrier) and fitted standard on all series.



### Cable gland

The cable gland is made of stainless steel AISI 316 and certified according to the norm ATEX EN 60079-0, EN 60079-1. Standard on all series.



### Horizontal Outlet DN65 PN10 - RPM 2850 1/min 2 poles

Picture for illustration purposes only



maximum pump efficiency

### Performance Curve

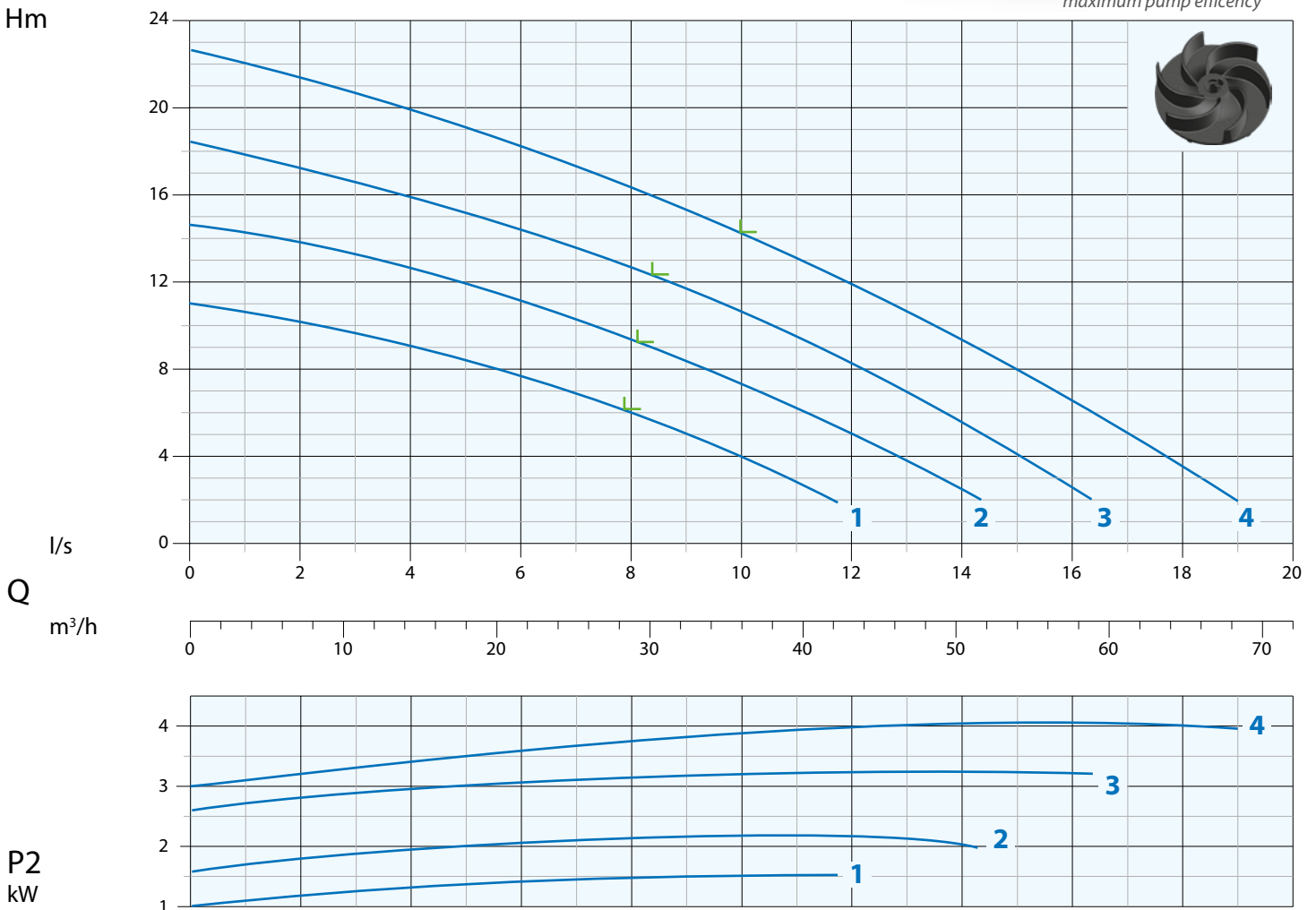

N°	Tipo Type	l/s	Flow Rate (m³/h)											
			1	2	4	6	8	10	12	14	16	19		
1	VM-VT 65/2/125 C.336	10,5	10	9	7,5	6	4	2						
2	VT 65/2/125 C.337	14,5	14	12,5	11	9,5	7,5	5	2,5					
3	VT 65/2/152 C.346	18	17,5	16	14,5	12,5	10,5	8,2	5,5	2,5				
4	VT 65/2/152 C.347	22	21,5	20	18	16,5	14	12	9,5	6,5	2			

N°	Tipo Type	EX	Mandata Delivery	Passaggio Free Passage	kW			R.P.M. 1/min	A			Hz
					P1	P2	HP		1 Phase - 230V	µf	3 Phase - 400V	
1	VM-VT 65/2/125 C.336	•	DN65 PN10	50 mm	1,7	1,5	2	2850	9,4	35	3,1	50
2	VT 65/2/125 C.337	•			3,1	2,2	3		5,3			
3	VT 65/2/152 C.346	•		55 mm	3,9	3,2	4		6,7			
4	VT 65/2/152 C.347	•			5,5	4,2	5,5		9,2			

• Available explosion proof pump

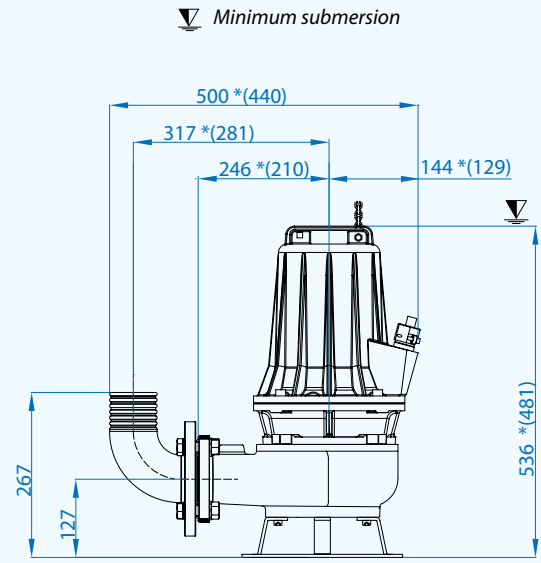
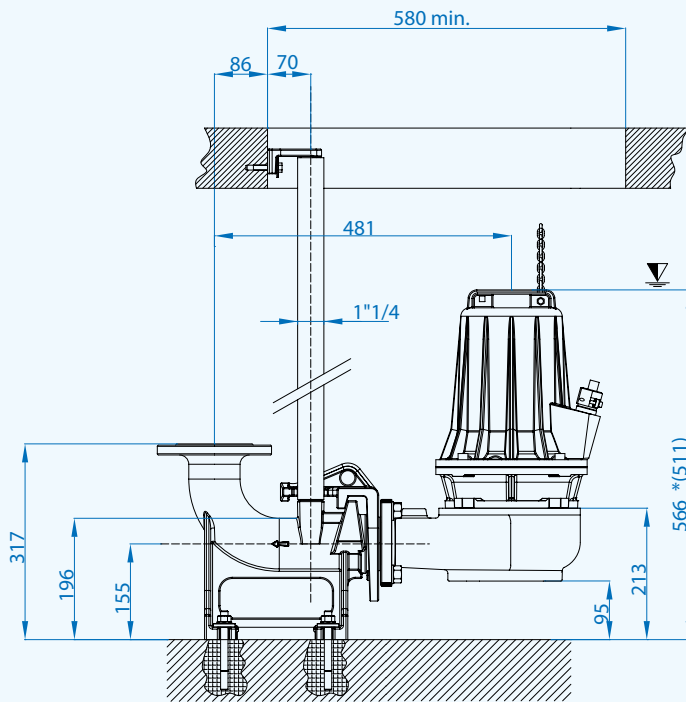

\*(VT 65/2/125 C.336-337)

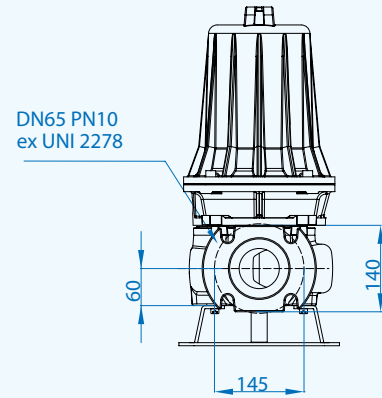
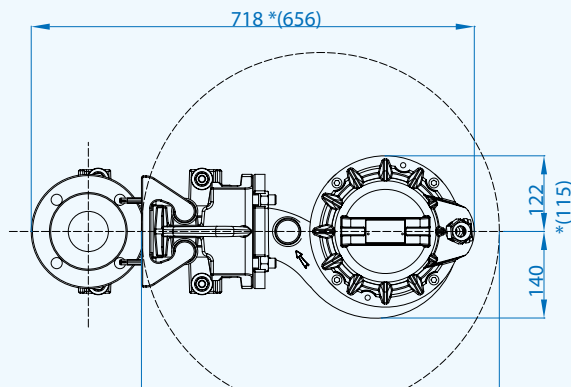
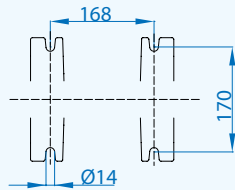

### Cables

Pumps	Version	Phases	Cable	Cable cross section mm <sup>2</sup>	mt
65/2/125	Standard	1 ~ 230V	H07RN8F	4x1,5+3x0,50 Ø15*	10
	ATEX		NSSHÖU-J	4x1,5+3x0,50 Ø17*	10
	Standard	3 ~ 400V	H07RN8F	4x1,5+3x0,50 Ø15**	10
	ATEX		D.O.L.	NSSHÖU-J	4x1,5+3x0,50 Ø17**
65/2/152	Standard	3 ~ 400V	H07RN8F	4x1,5+3x0,50 Ø15**	10
	ATEX		D.O.L.	NSSHÖU-J	4x1,5+3x0,50 Ø17**

\* Standard with Control-box \*\* Free terminals

### Packaging dimension

Type	X mm	Y mm	Z mm	Kg
VM-VT 65/2/125 C.336	295	460	330	41,5
VT 65/2/125 C.337				42,5
VT 65/2/152 C.346	355	580	420	59
VT 65/2/152 C.347				62

### Optional



Explosion proof control box available on request

### Horizontal Outlet DN80 PN16 - RPM 2850 1/min 2 poles

Picture for illustration purposes only



### Performance Curve

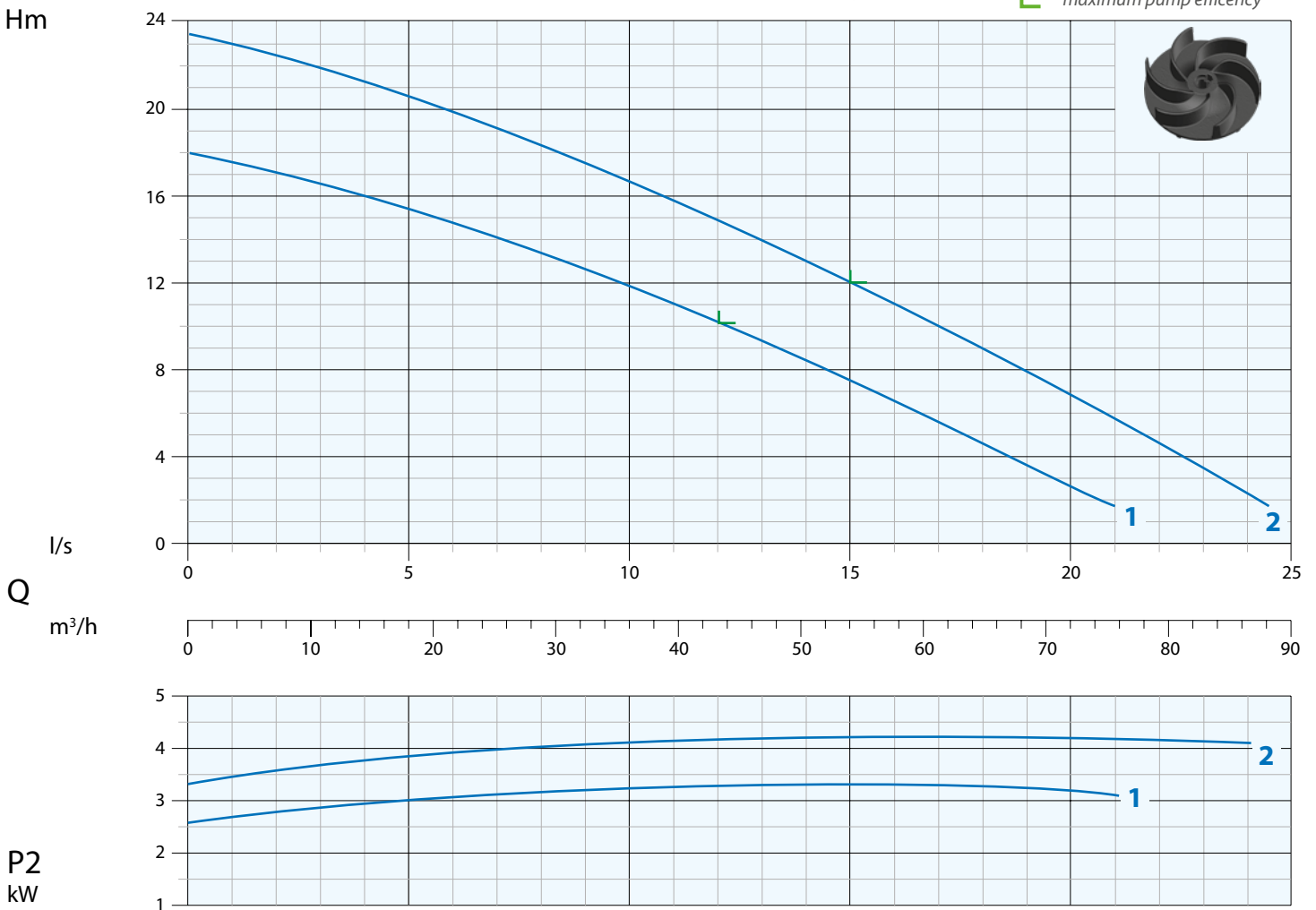

N°	Type		2	4	6	8	10	12	16	20	22	24
			l/s	l/m	m³/h	mt	mt	mt	mt	mt	mt	mt
1	VT 80/2/152 C.346		17	16	15	13,5	12	10	6,5	2,5		
2	VT 80/2/152 C.347		22,5	21	20	18,5	16,5	15	11	7	4,5	2

N°	Type	EX	Delivery	Free Passage	kW		HP	R.P.M. 1/min	A		Hz
					P1	P2			3 Phase - 400V		
1	VT 80/2/152 C.346	•	DN80 PN16	50 mm	3,9	3,2	4,3	2850	6,9		50
2	VT 80/2/152 C.347	•			5,5	4,2	5,7		9,2		

• Available explosion proof pump

CE 0477  
EPT 17 ATEX 2702 X

Ex II 2G Ex db IIB T4 Gb  
Ex h IIB T4 Gb  
0° Ta ° 40°

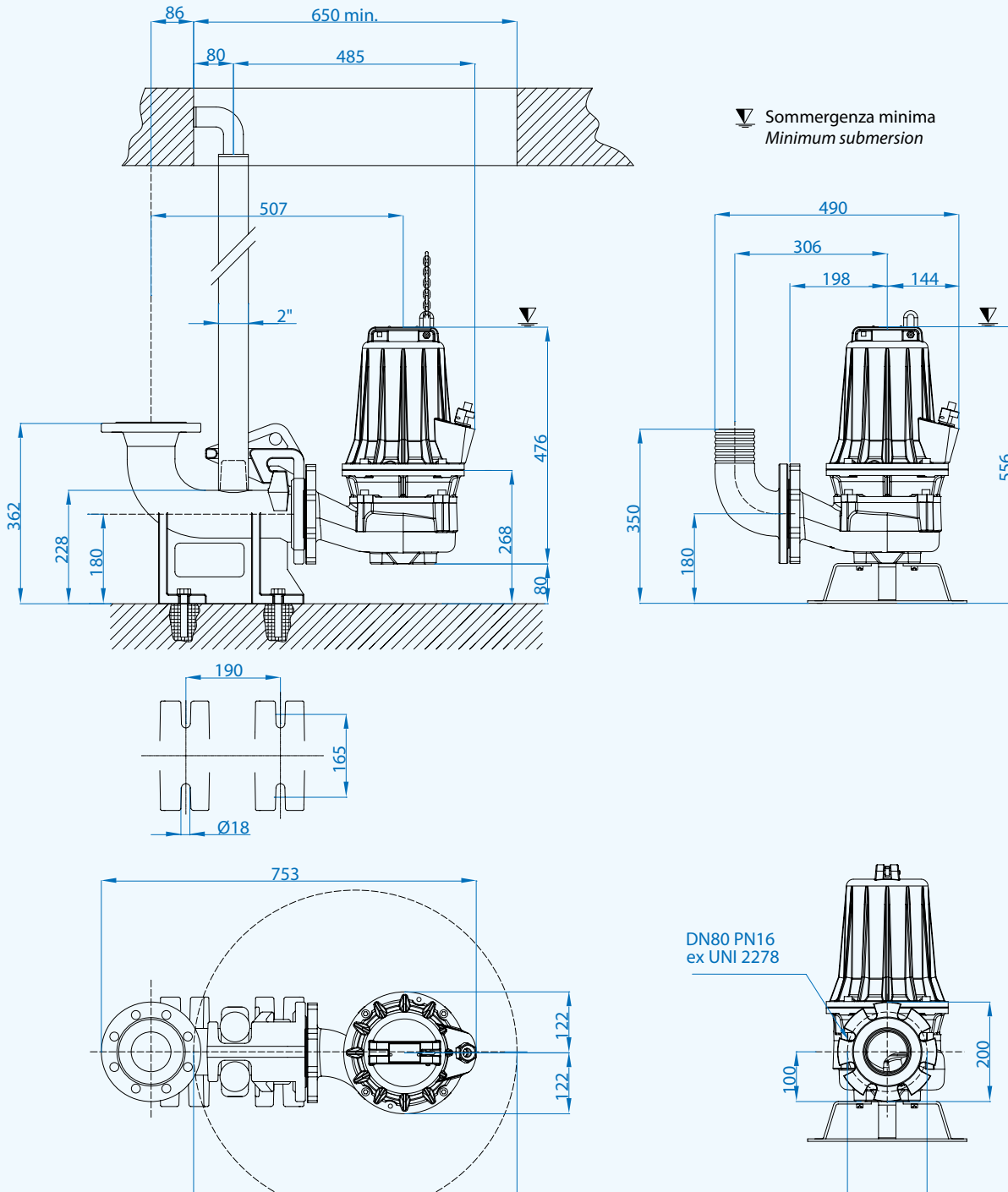

### Cables

Version	Phases	Cable	Cable cross section mm <sup>2</sup>	mt
Standard	3 ~ 400V	H07RN8F	4x1,5+3x0,50 $\varnothing 15^*$	10
ATEX	D.O.L.	NSSHÖU-J	4x1,5+3x0,50 $\varnothing 17^*$	10

\* Free terminals

### Packaging dimension

Type	X mm	Y mm	Z mm	Kg
VT 80/2/152 C.346	355	580	420	60
VT 80/2/152 C.347				63,5

### Optional



Automatic coupling foot  
Type: DUTY 80 and B5



Flanged hose connection N2  
Foot support P4



Stainless steel handle

### Horizontal Outlet DN80 PN16 - RPM 2850 1/min 2 poles

Picture for illustration purposes only



maximum pump efficiency

### Performance Curve

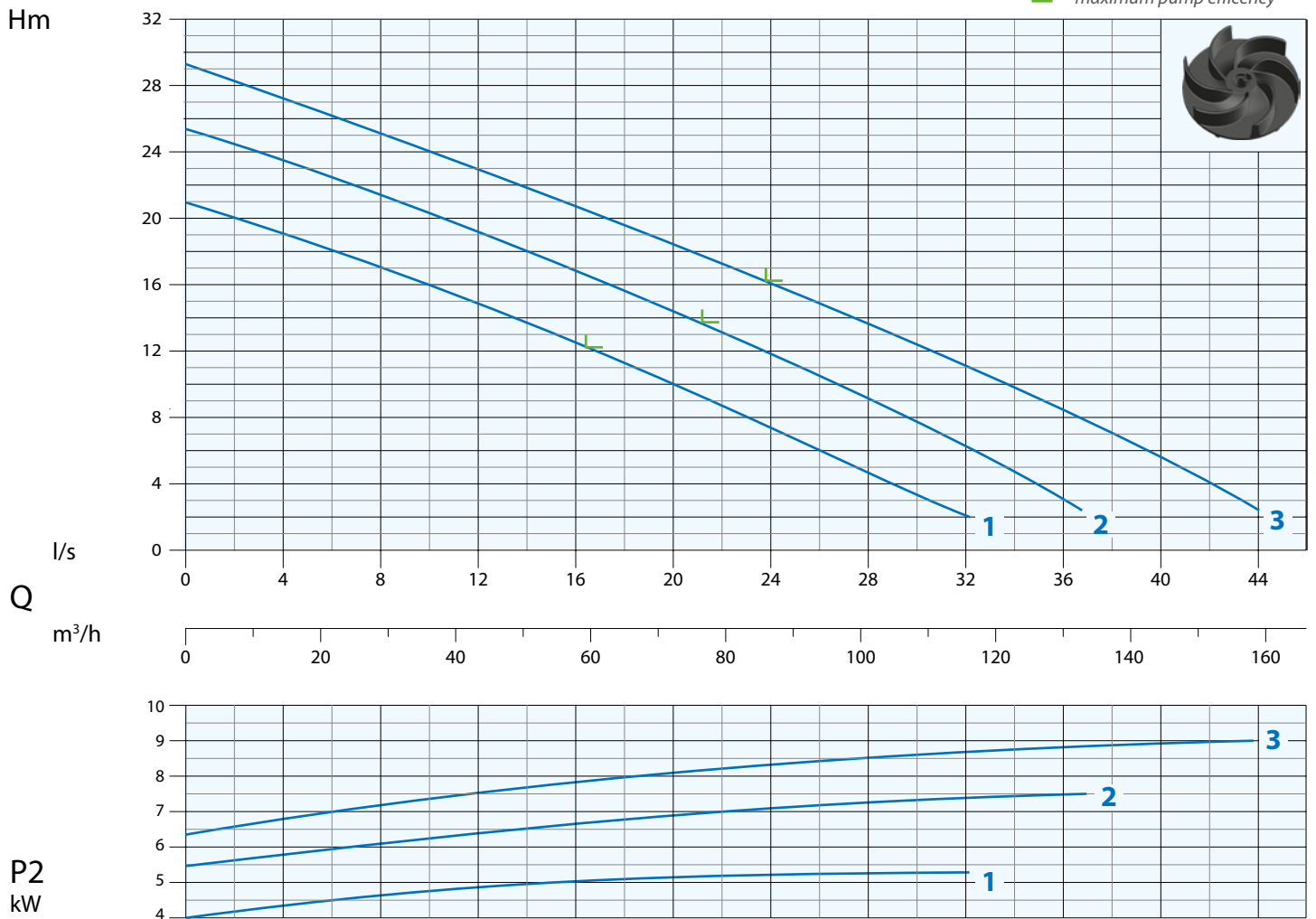

N°	Type		l/s	2	4	8	12	16	20	24	28	32	36	40
			l/m	120	240	480	720	960	1200	1440	1680	1920	2160	2400
			m³/h	7,2	14,4	28,8	43,2	57,6	72	86,4	100,8	115,2	129,6	144
1	VT 80/2/173 C.354	mt	20	19	17	15	12,5	10	7,5	5	2			
2	VT 80/2/173 C.357	mt	24,5	23,5	21,5	19,5	17	14,5	12	9	6	3		
3	VT 80/2/173 C.359	mt	28	27	25	23	21	18,5	16	13,5	11	8,5	5,5	

N°	Type	EX	Delivery	Free Passage	kW			HP	R.P.M. 1/min	A	
					P1	P2	3 Phase - 400V			Hz	
1	VT 80/2/173 C.354	•			6,2	5,2	7			10,8	
2	VT 80/2/173 C.357	•	DN80 PN16	70 mm	9,2	7,5	10	2850		14,5	50
3	VT 80/2/173 C.359				11,2	9,2	12			18,3	

• Available explosion proof pump

CE<sub>0477</sub> EPT 17 ATEX 2702 X II 2G Ex db IIB T4 Gb Ex h IIB T4 Gb 0° Ta° 40°

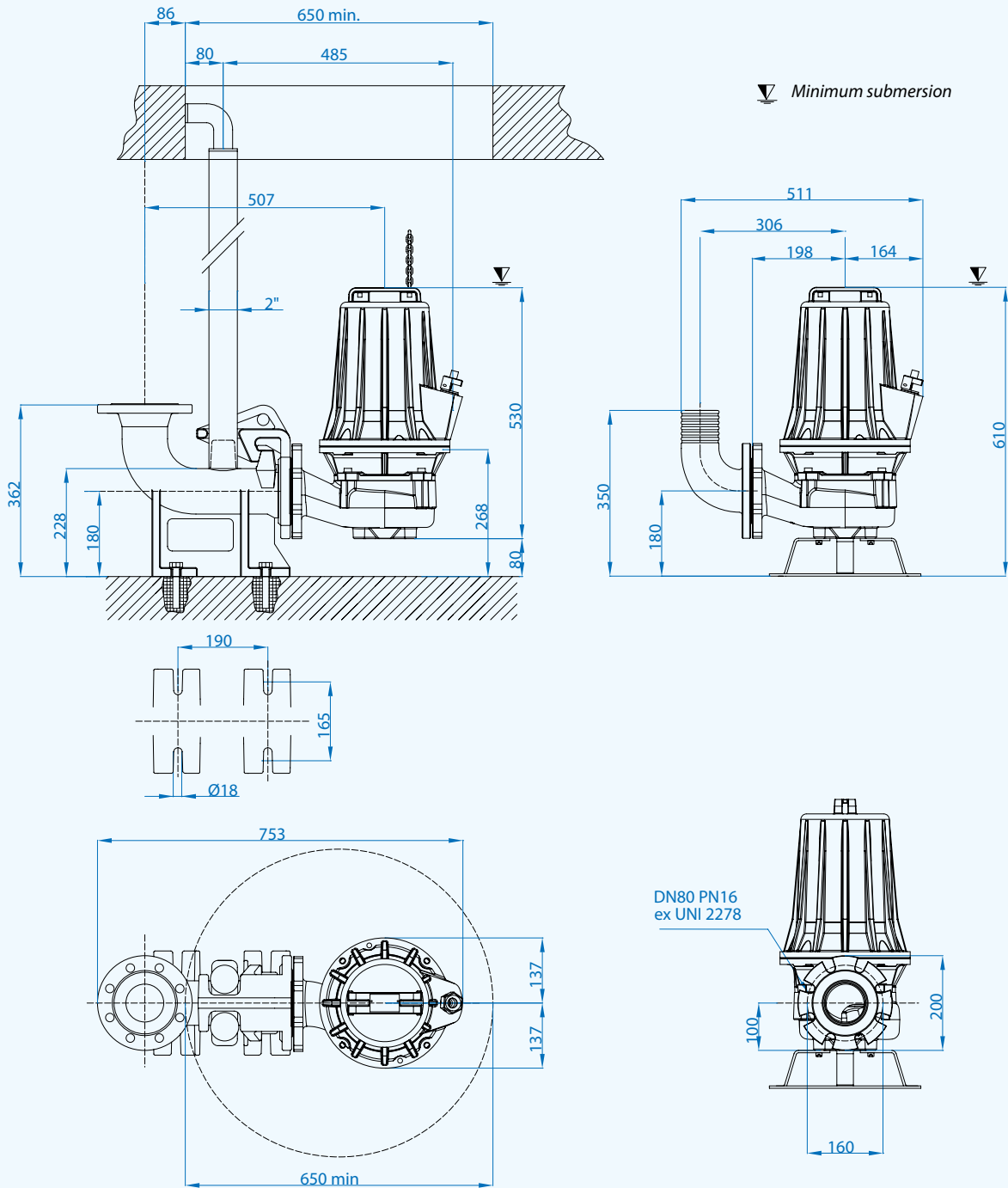

### Cables

Version	Phases	Cable	Cable cross section mm <sup>2</sup>	mt
Standard	3 ~ 400V	H07RN8F	7x1,5+3x0,50 Ø17*	10
ATEX	Y-Δ	NSSHÖU-J	7x1,5+3x0,50 Ø17*	10

\* Free terminals

### Packaging dimension

Type	X mm	Y mm	Z mm	Kg
VT 80/2/173 C.354				86,5
VT 80/2/173 C.357	355	580	420	91
VT 80/2/173 C.359				92

### Optional



Automatic coupling foot  
Type: DUTY 80 and B5



Flanged hose connection N2  
Foot support PS



Stainless steel handle

## Submersible electropumps with Vortex impeller

Power:	12÷40 kW
Delivery	DN80 - 100



### Application

The VTH 2 poles Series is used for pumping sewage with suspended solids. High performance renders it useful in a variety of applications including water treatment plants, industrial plants, farming and sewage.

### Characteristic

All main components are made of grey cast iron GG25. Two individual mechanical seals (motor side in the oil chamber, impeller side in contact with the liquid) and high quality parts, ensure the perfect functioning and reliability of the product.

### Motor range

- Squirrel cage motor 2 poles
- Thermal protection T1 and T2 embedded in the motor winding (to be wired to the three pole contactor in the control panel)
- Class F insulation (155°C)
- IP 68 protection

### Motor cooling

The cooling of the motor is ensured by the liquid where the pump is submerged.

### Limits of use

- Max. permissible liquid temperature: 40°C with pump fully submerged
- On request, special version (excluded ATEX) to withstand liquid temperature up to 60°C with pump fully submerged, no S1 service
- Maximum depth of immersion: 20 mt
- Permissible pH value: 6-10
- Hydraulic features suitable for liquids with density <math>< 1,1 \text{ kg/dm}^3</math>
- Allowed voltage: 230/400V or 400/690V±5% depending on the pump
- Allowed frequency: 50Hz ±2%

### Designation

VTH EX 100 - 2 / 250

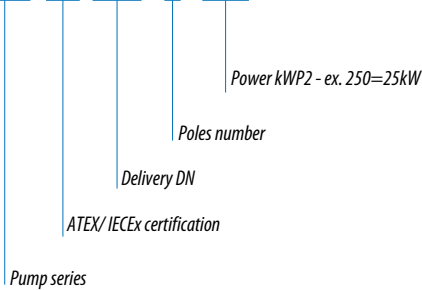

### Performance Overview

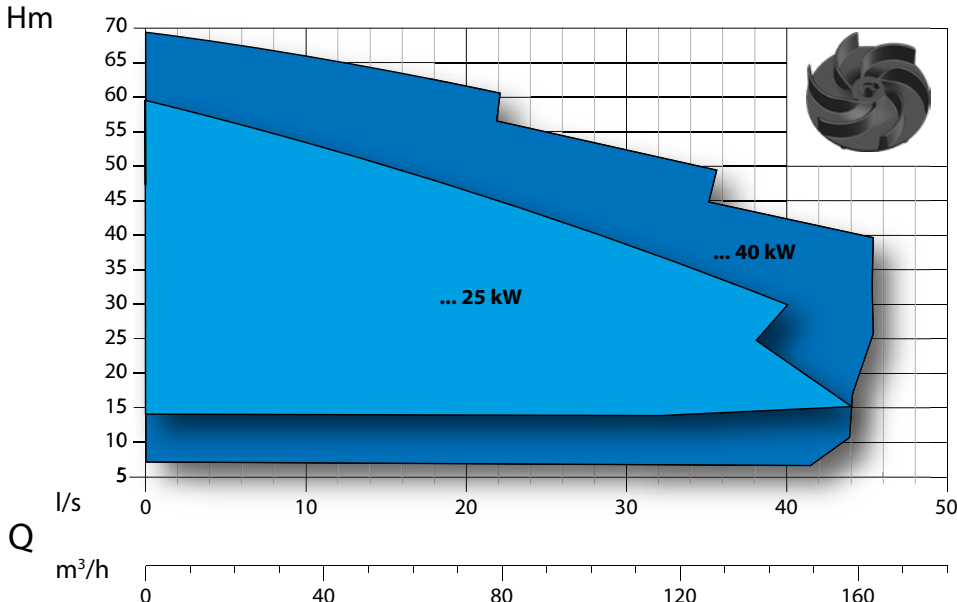

### Curves Identification

- DN80
- DN100

### Norms

According to ISO 9906:2012 3B2

## List of components and materials

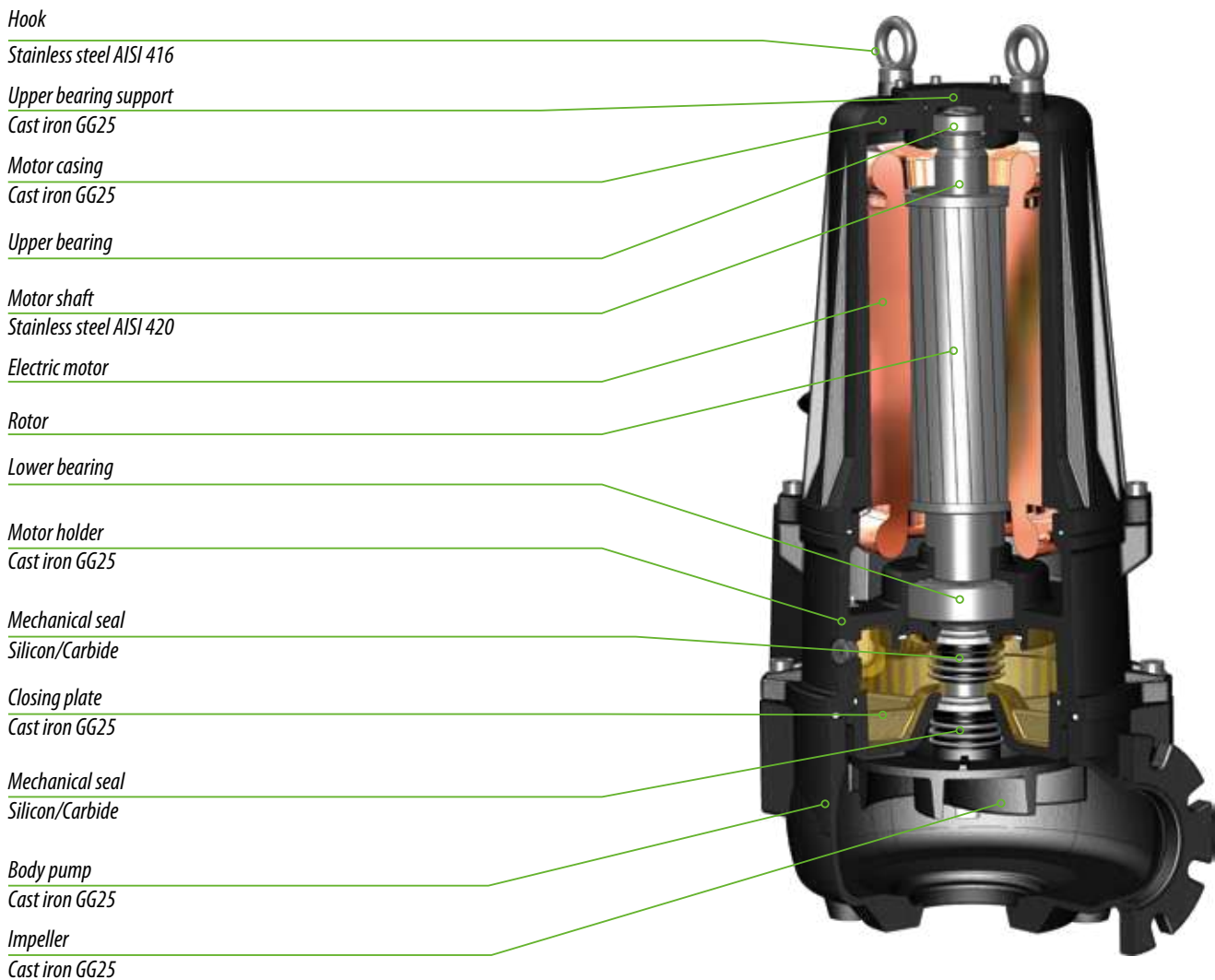

## Technology and Features

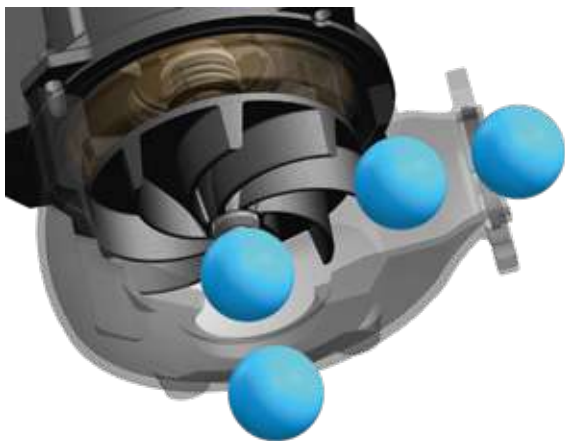

### Impellers

Impellers have been studied to grant excellent performances and ample solid handling.



### Explosion proof pumps



Ex db IIB T4 Gb  
Ex h IIB T4 Gb  
0° ~ Ta ~ 40°

EPT 17 ATEX 2703 X



These certificates grant for the safe use of the product in hazardous area in line with the stringent European and International standards ATEX/IECEX.



### Seal leak detector

The seal leak detector is certified according to the norm EN 60079-0, EN 60079-1 (through safety barrier) and fitted standard on all series (not applicable with IECEX).



### Bearings

The series is fitted with a cylindrical roller bearing (upper bearing) to absorb the thrust and vibration generated by the pump shaft.



### Horizontal Outlet DN80 PN16 - RPM 2850 1/min 2 poles

Picture for illustration purposes only



### Performance Curve

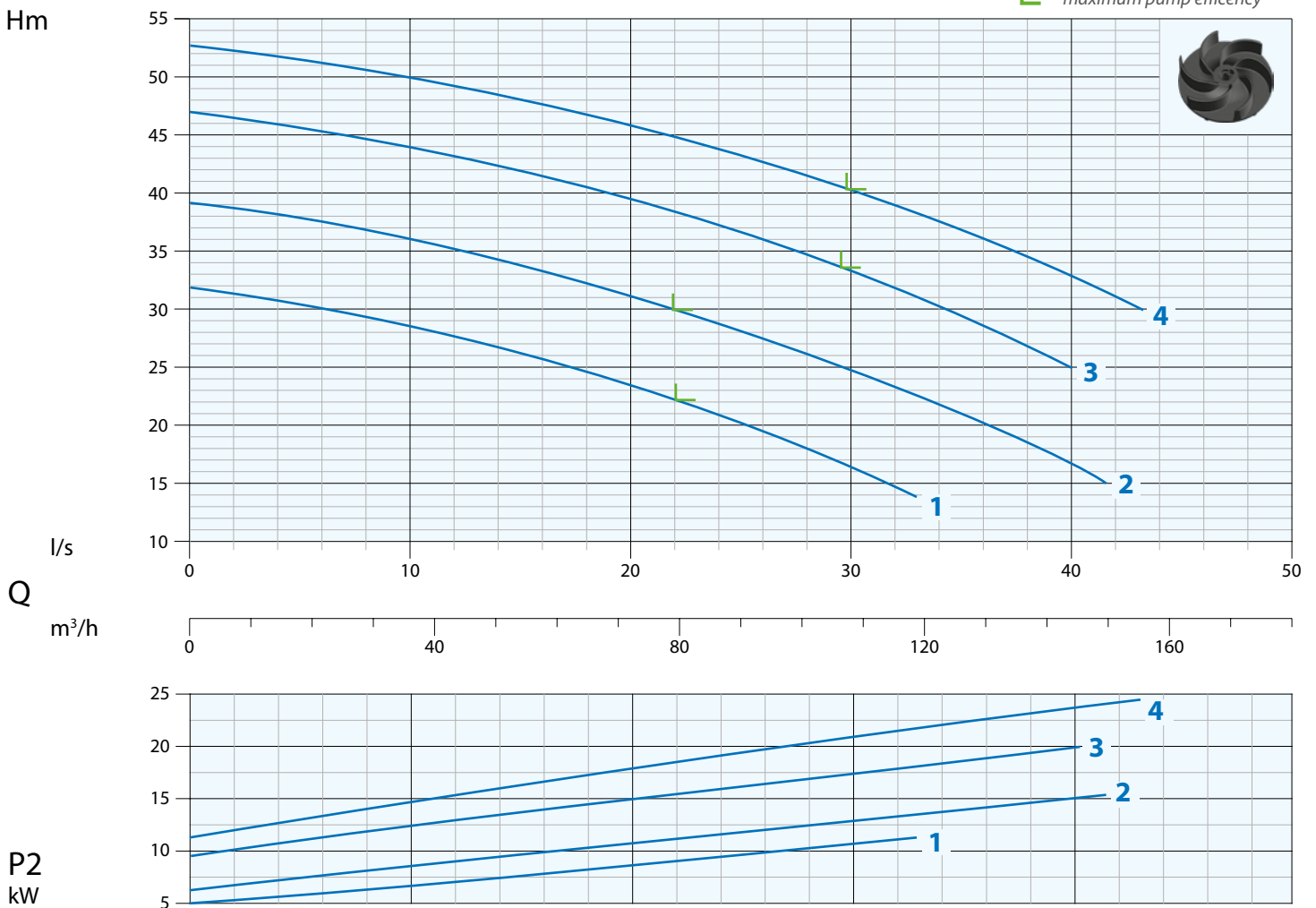

N°	Type	l/s	Q									
			4	8	10	14	20	24	30	34	40	42
		l/m	240	480	600	840	1200	1440	1800	2040	2400	2520
		m <sup>3</sup> /h	14,4	28,8	36	50,4	72	86,4	108	122,4	144	151,2
1	VTH 80-2/120	mt	31	29	28,5	27	23,5	21	16,5			
2	VTH 80-2/150		38	37	36	34	31	29	25	22	17	
3	VTH 80-2/200		46	45	44	42	39,5	37	33	30	25	
4	VTH 80-2/250		52	51	50	48,5	46	44	40	37,5	33	31

N°	Type	EX	Delivery	Free Passage	kW		HP	R.P.M. 1/min	A 3 Phase - 400V	Hz
					P1	P2				
1	VTH 80-2/120	•	DN80 PN16	70 mm	13,4	12	16	2850	22	50
2	VTH 80-2/150	•			17,2	15	20		29,5	
3	VTH 80-2/200	•			23,7	20	27		41	
4	VTH 80-2/250	•			28,2	25	33		47,5	

• Available explosion proof pump with certifications:



Ex db IIB T4 Gb  
Ex h IIB T4 Gb  
0° Ta - 40°

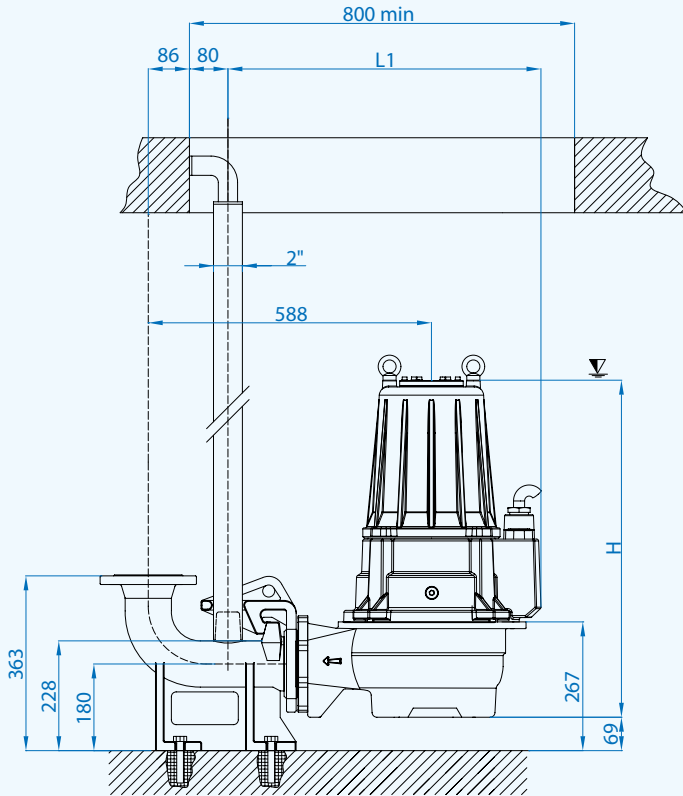

▽ Minimum submersion

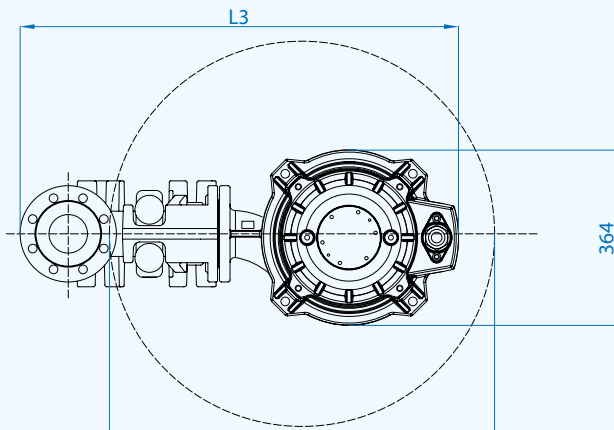
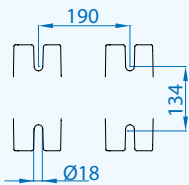
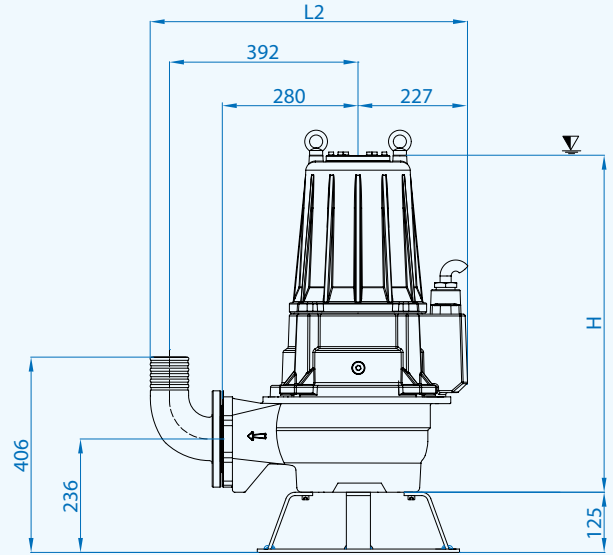

	H	L1	L2	L3
VTH 80-2/120-150	700	650	655	911
VTH 80-2/200-250	741	678	683	934

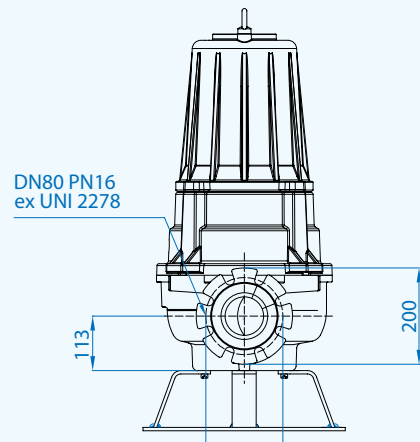

### Cables

Pumps	Version	Phases	Cable	Cable cross section mm <sup>2</sup>	mt
80-2/120-150	Standard	3 ~ 400V	H07RN8F	10x2,5 Ø23*	10
	ATEX	Y-Δ	NSSHÖU-J	7x2,5+3x0,50 Ø20*	10
80-2/200-250	Standard	3 ~ 400V	H07RN8F	7x4+3x1 Ø20,5*	10
	ATEX	Y-Δ	NSSHÖU-J	7x6+3x1 Ø24*	10

\* Free terminals

### Packaging dimension

Tipo - Type	X mm	Y mm	Z mm	Kg
VTH 80-2/120	510	860	420	186
VTH 80-2/150				195
VTH 80-2/200				242
VTH 80-2/250				244

### Optional



Automatic coupling foot  
Type: DUTY 80 and B5



Flanged hose connection N2  
Foot support P7

### Horizontal Outlet DN100 PN16 - RPM 2850 1/min 2 poles

Picture for illustration purposes only



### Performance Curve

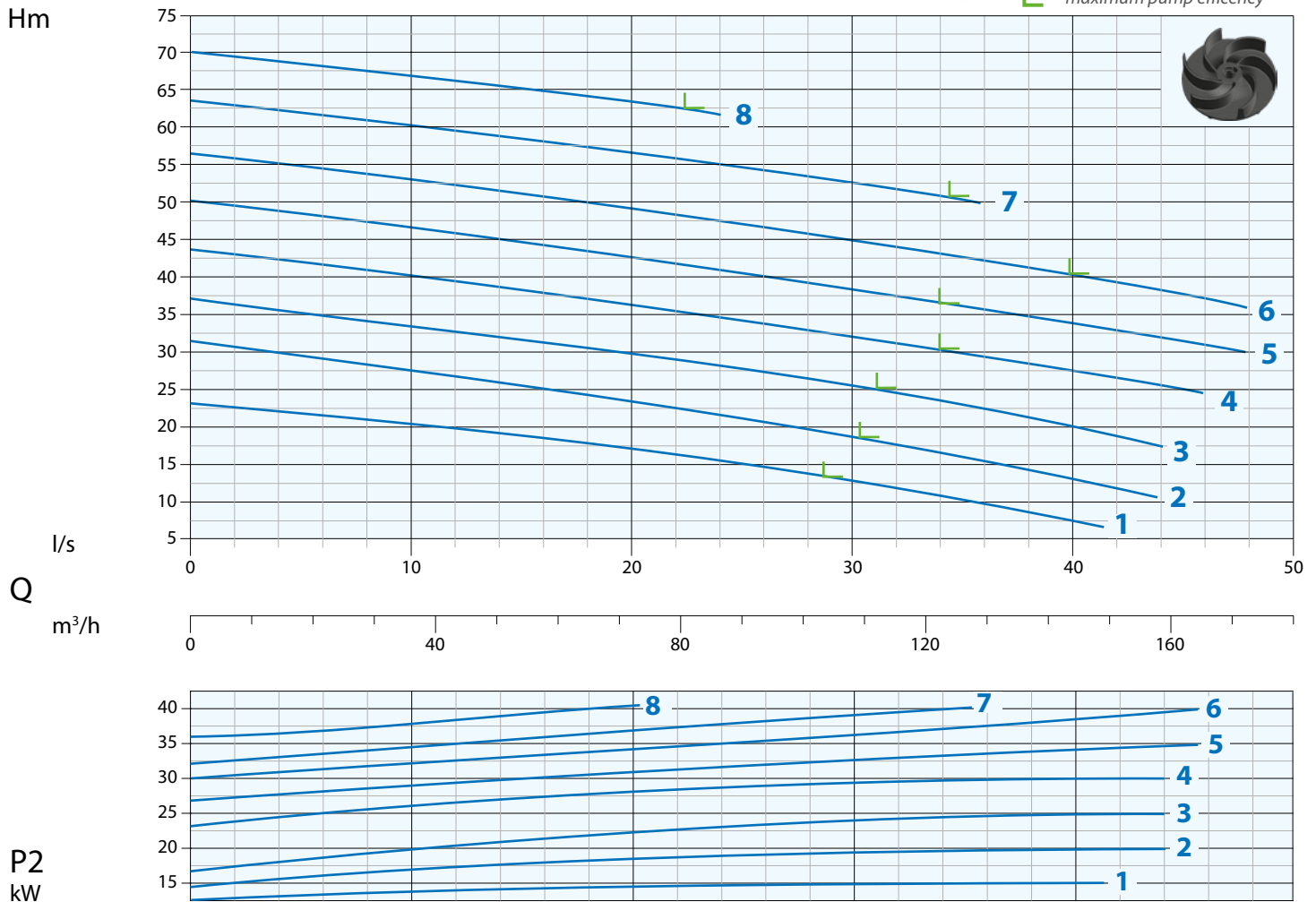

N°	Type	I/s	4	8	10	14	20	24	30	34	40	42
		l/m	240	480	600	840	1200	1440	1800	2040	2400	2520
		m³/h	14,4	28,8	36	50,4	72	86,4	108	122,4	144	151,2
1	VTH 100-2/150	mt	22,5	21	20,5	18	17	15	12,5	11	7,5	
2	VTH 100-2/200		30	28	27,5	26	23,5	22	18,5	16,5	12,5	12
3	VTH 100-2/250		35,5	34,5	33	32,5	30	28	26,5	23,5	20	18
4	VTH 100-2/300		42,5	40,5	40	38,5	36	35	32	31	27,5	27
5	VTH 100-2/350		48,5	47	46	45	42,5	41	38	37	34	32,5
6	VTH 100-2/400		55,5	54	53	52	49	47,5	45	43	40	39
7	VTH 100-2/400-1		62,5	61	60	58,5	57	55	52,5	51		
8	VTH 100-2/400-2		68	67,5	66,5	65	63	62				

N°	Type	EX	Delivery	Free Passage	kW			R.P.M. 1/min	A		
					P1	P2	HP		3 Phase - 400V		
								Hz			
1	VTH 100-2/150	•	DN100 PN16	100 mm	17,2	15	20	2850	30,2		50
2	VTH 100-2/200	•			23,7	20	27		40,4		
3	VTH 100-2/250	•			28,2	25	34		47,4		
4	VTH 100-2/300	•			37,4	30	41		59,7		
5	VTH 100-2/350	•			40,6	35	47,5		65,1		
6	VTH 100-2/400	•			48,2	40	54		76,2		
7	VTH 100-2/400-1	•			48,2	40	54		76,2		
8	VTH 100-2/400-2	•			48,6	40	54		76,5		

• Available explosion proof pump with certifications:



Ex db IIB T4 Gb  
Ex h IIB T4 Gb  
0° Ta 40°

EPT 17 ATEX 2703 X

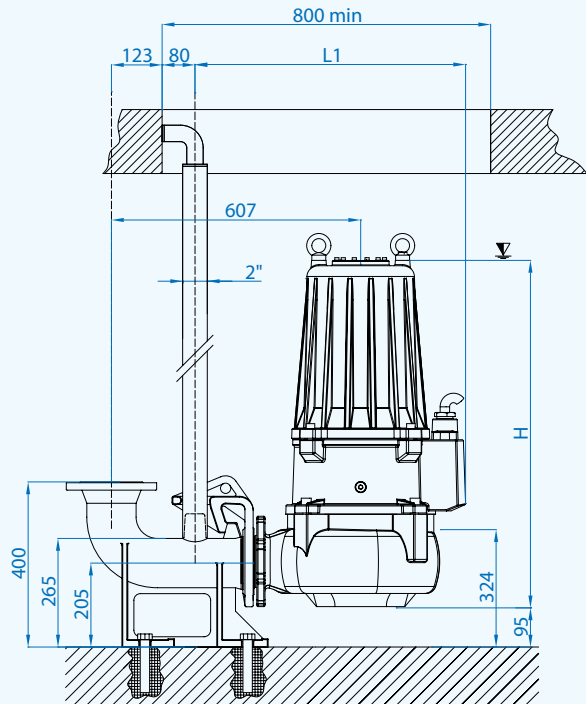

▽ Minimum submersion

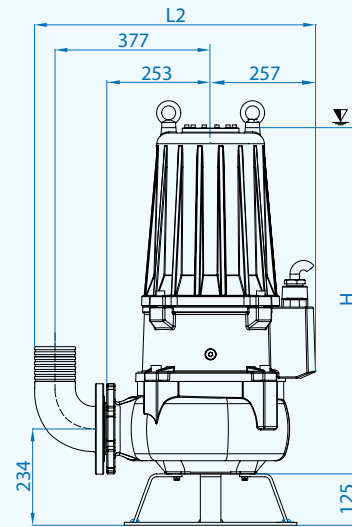

	H	L1	L2	L3
<b>VTH 100-2/150</b>	728	650	659	911
<b>VTH 100-2/200-250</b>	769	659	684	969
<b>VTH 100-2/300-350-400</b>	843	659	684	969

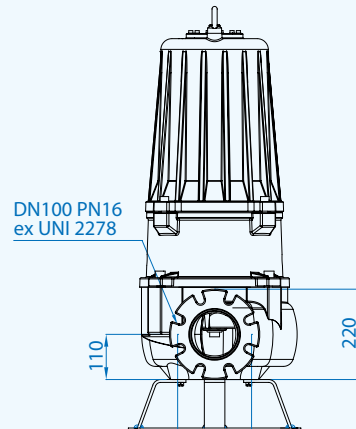
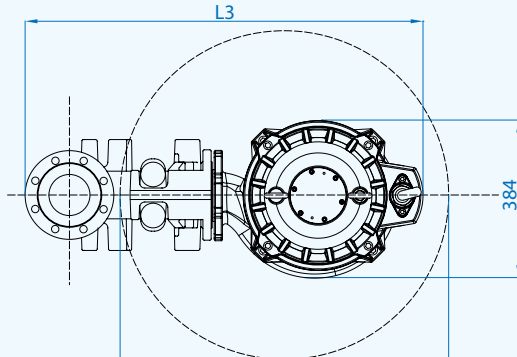
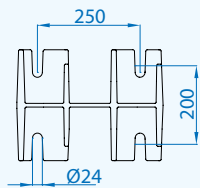

### Cables

Pumps	Version	Phases	Cable	Cable cross section mm <sup>2</sup>	mt
<b>100-2/150</b>	Standard	3 ~ 400V	H07RN8F	10x2,5 Ø23*	10
	ATEX	Y-Δ	NSSHÖU-J	7x2,5+3x0,50 Ø20*	10
<b>100-2/200-250</b>	Standard	3 ~ 400V	H07RN8F	7x4+3x1 Ø20,5*	10
	ATEX	Y-Δ	NSSHÖU-J	7x6+3x1 Ø24*	10
<b>100-2/300-350-400</b>	Standard	3 ~ 400V	NSSHÖU-J	7x6+3x1 Ø24*	10
	ATEX	Y-Δ	NSSHÖU-J	7x6+3x1 Ø24*	10

\* Free terminals

### Packaging dimension

Tipo - Type	X mm	Y mm	Z mm	Kg
<b>VTH 100-2/150</b>	510	860	420	210
<b>VTH 100-2/200</b>				252
<b>VTH 100-2/250</b>				254
<b>VTH 100-2/300</b>				310
<b>VTH 100-2/350</b>				340
<b>VTH 100-2/400</b>				380
<b>VTH 100-2/400-1</b>				382
<b>VTH 100-2/400-2</b>				385



### Optional



Automatic coupling foot  
Type: DUTY 100 and B6

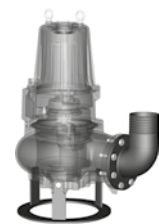

Flanged hose connection N3  
Foot support P7

### Submersible electropumps with Vortex impeller

Power:	<b>1.1 ÷ 7.5 kW</b>
Delivery:	<b>DN80 - 100</b>



#### Application

The VT 4 poles Series is used for transport of water with heavy suspended solids. High performance and a wide channel permits its use in industry, including tanneries and farms, and for the movement of water contaminated with soil, or containing large solid pieces.

#### Characteristic

All main components are made of grey cast iron GG25. Two individual mechanical seals (motor side in the oil chamber, impeller side in contact with the liquid) and high quality parts, ensure the perfect functioning and reliability of the product.

#### Motor range

- Squirrel cage motor 4 poles
- Thermal protection T1 and T2 embedded in the motor winding (to be wired to the three pole contactor in the control panel)
- Class F insulation (155°C)
- IP 68 protection

#### Motor cooling

The cooling of the motor is ensured by the liquid where the pump is submerged.

#### Limits of use

- Max. permissible liquid temperature: 40°C with pump fully submerged
- On request, special version (excluded ATEX) to withstand liquid temperature up to 60°C with pump fully submerged, no S1 service
- Maximum depth of immersion: 20 mt
- Permissible pH value: 6-10
- Hydraulic features suitable for liquids with density <math>< 1,1 \text{ kg/dm}^3</math>
- Allowed voltage: 230/400V or 400/690V  $\pm 5\%$  depending on the pump
- Allowed frequency: 50Hz  $\pm 2\%$

#### Designation

**VT-EX 80 / 4 / 173 C.356**

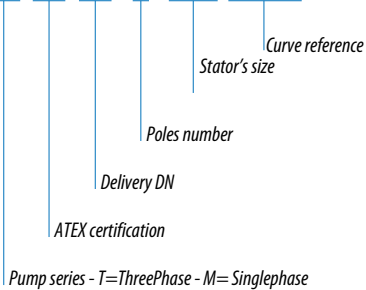

#### Performance Overview

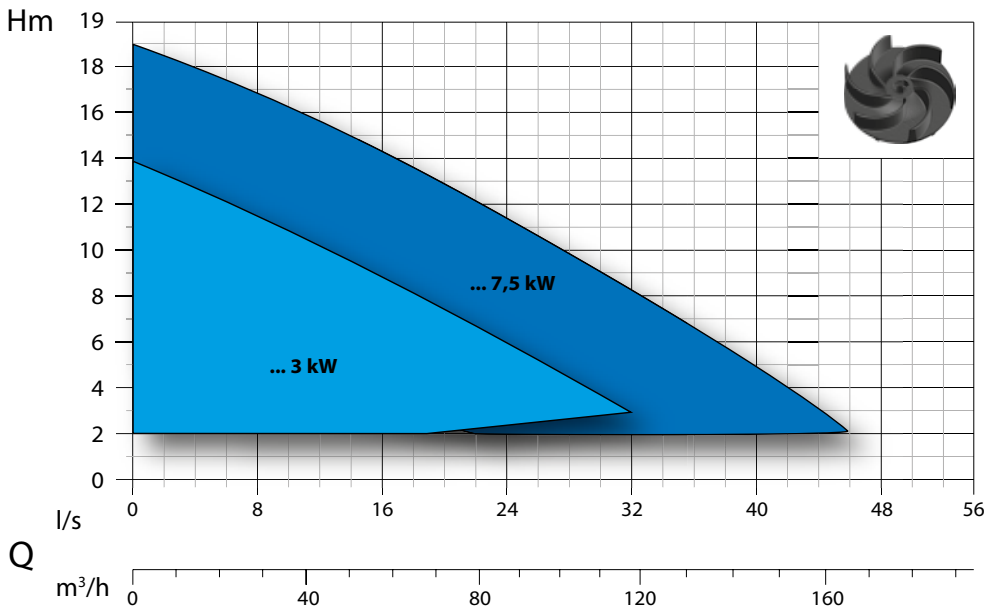

#### Curves Identification

- DN80
- DN100

#### Norms

According to ISO 9906:2012 3B2

## List of components and materials

**Chain ring**  
Stainless steel AISI 416

**Motor casing**  
- Cast iron GG25

**Upper bearing**

**Motor shaft** Stainless steel AISI 420

**Electric motor**

**Rotor**

**Lower bearing**

**Motor holder**  
Cast iron GG25

**Mechanical seal**  
Carbon/Ceramic (CA/CE/Viton)

**Motor holder**  
Cast iron GG25

**Mechanical seal**  
Silicon/Carbide (SIC/SIC/Viton)

**Body pump**  
Cast iron GG25

**Impeller**  
Cast iron GG25

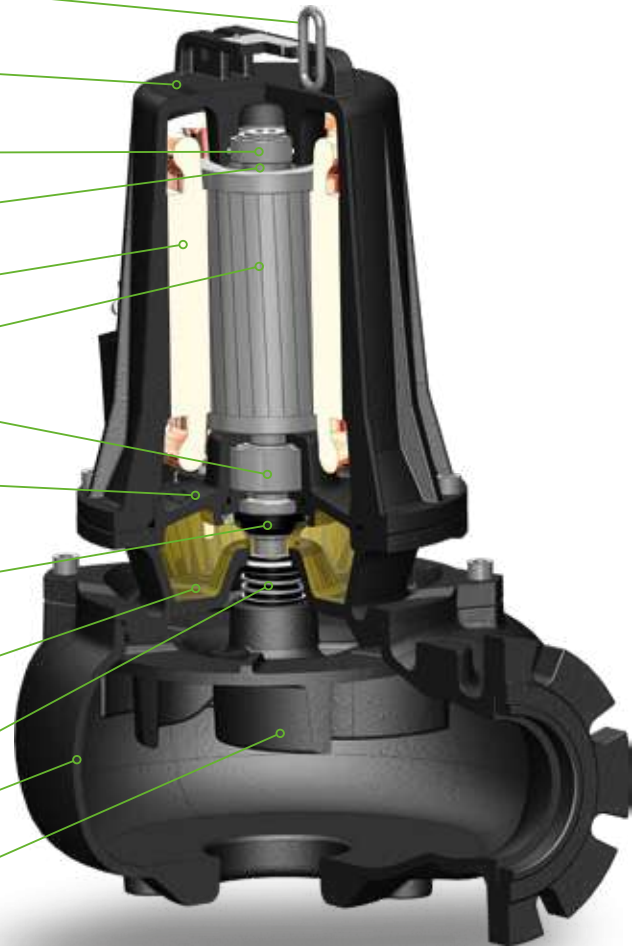

## Technology and Features

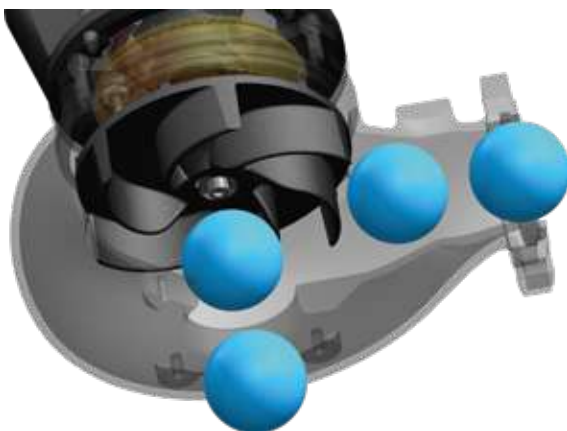

### Impellers

Impellers have been studied to grant excellent performances and ample solid handling.



### Explosion proof pumps



0477  
EPT 17 ATEX 2702 X



II 2G Ex db IIB T4 Gb  
Ex h IIB T4 Gb  
0° Ta ~ 40°

Pumps with explosion proof available on request.



### Seal leak detector

The seal leak detector is certified according to the norm ATEX EN 60079-0, EN 60079-1 (through safety barrier) and fitted standard on all series.



### Cable gland

The cable gland is made of stainless steel AISI 316 and certified according to the norm ATEX EN 60079-0, EN 60079-1. Standard on all series.

### Horizontal Outlet DN65 PN10 - RPM 1450 1/min 4 poles

Picture for illustration purposes only



maximum pump efficiency

#### Performance Curve

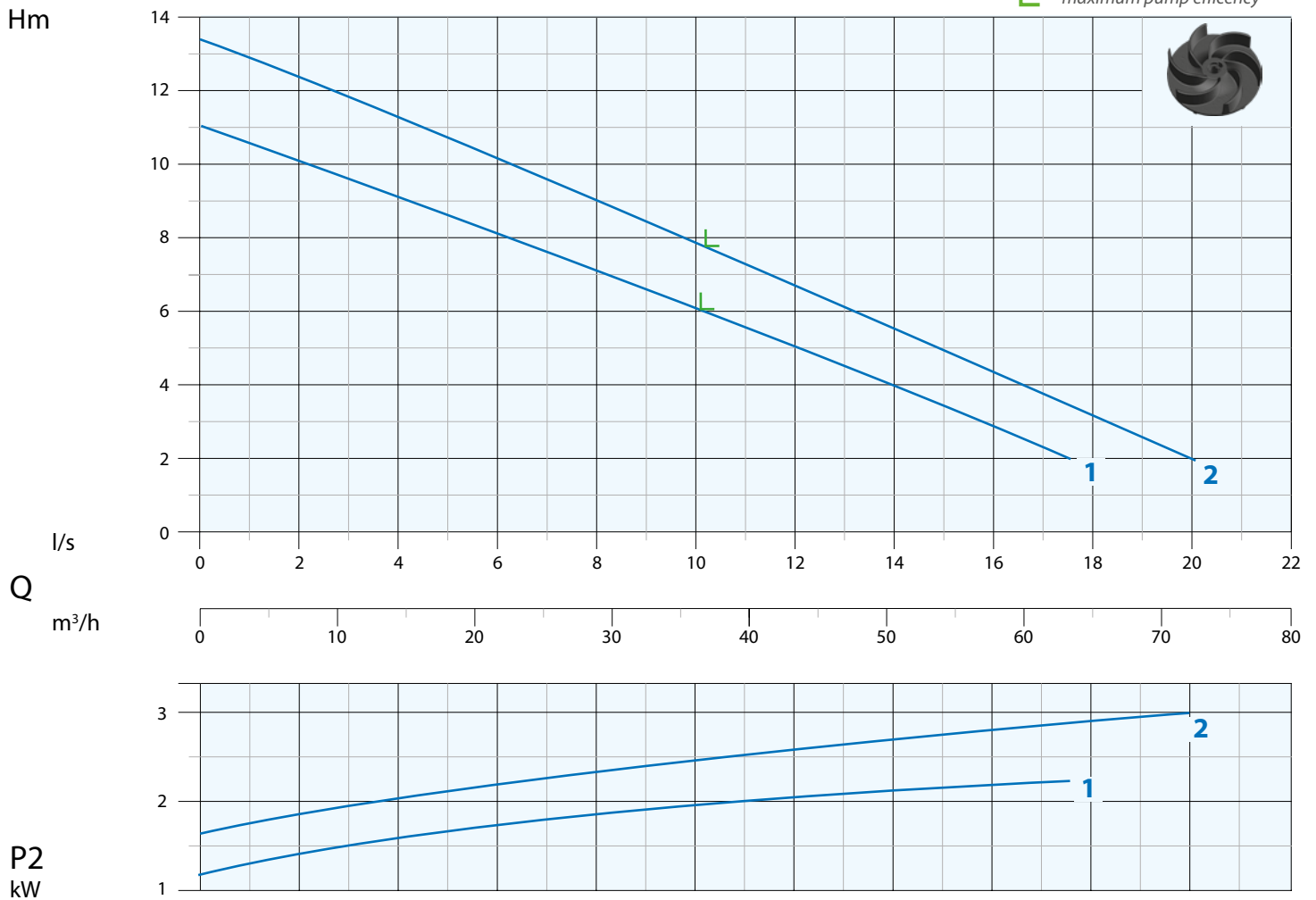

N°	Type	Flow (Q)										
		l/s	2	4	6	8	10	12	14	16	18	20
		l/m	120	140	360	480	600	720	840	960	1080	1320
		m³/h	7,2	14,4	21,6	28,8	36,0	43,2	72	57,6	64,8	86,4
1	VT 65/4/152 C.344	mt	10	9	8,5	8	6	5	4	3		
2	VT 65/4/152 C.345	mt	12,5	11,2	10,5	10	7,8	7,5	6,5	4,5	3	2

N°	Type	EX	Delivery	Free Passage	kW		HP	R.P.M. 1/min	A 3 Phase - 400V	Hz
					P1	P2				
1	VT 65/4/152 C.344		DN65 PN10	65 mm	2,8	2,2	3	1450	5,2	50
2	VT 65/4/152 C.345				3,8	3	4		7,2	

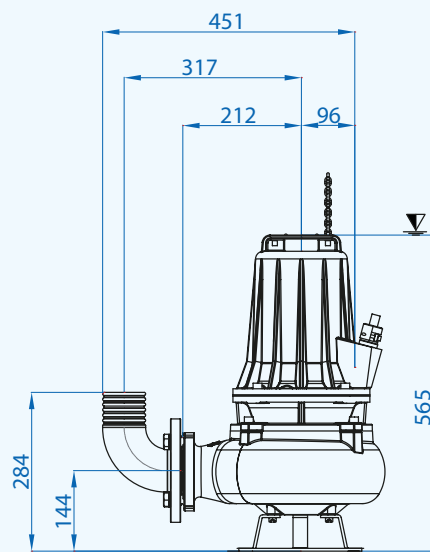
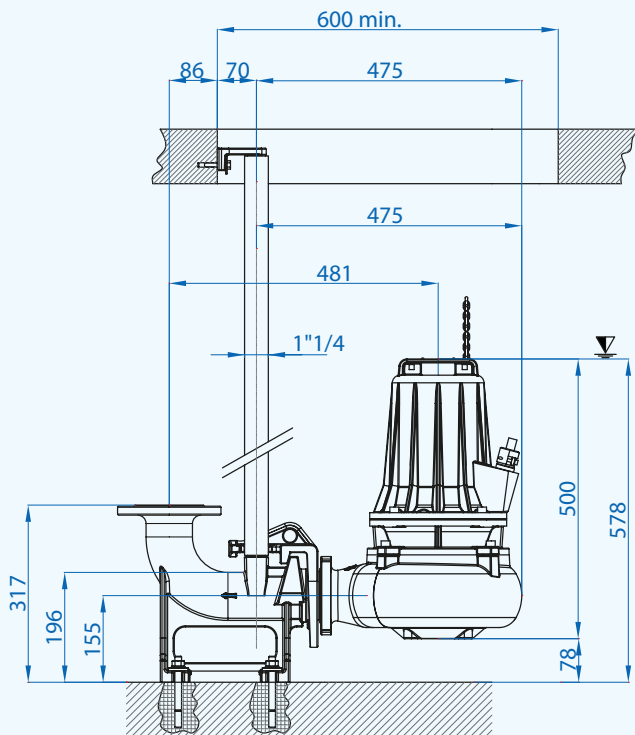

▽ Minimum submersion

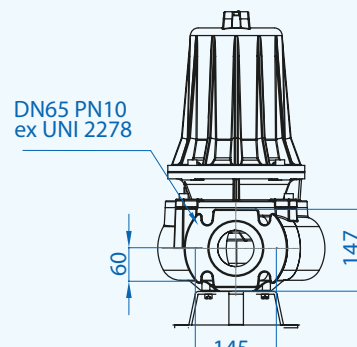
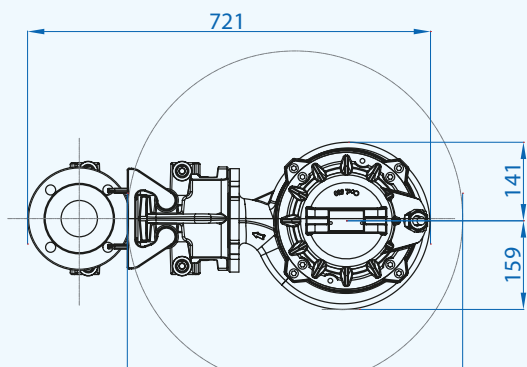
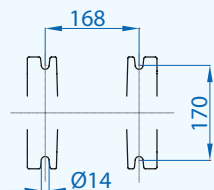

### Cables

Pumps	Phases	Cable	Cable cross section mm <sup>2</sup>	mt
65/4/152	3 ~ 400V D.O.L.	H07RN8F	4x1,5+3x0,50 Ø15*	10

\* Free terminals

### Packaging dimension

Tipo - Type	X mm	Y mm	Z mm	Kg
VT 65/4/152 C.344	355	580	420	66
VT 65/4/152 C.345				70

### Optional



Automatic coupling foot  
Type: DUTY 65 and B4 PN10



Flanged hose connection N5  
Foot support P4



Stainless steel handle



### Horizontal Outlet DN80 PN16 - RPM 1450 1/min 4 poles

Picture for illustration purposes only



### Performance Curve

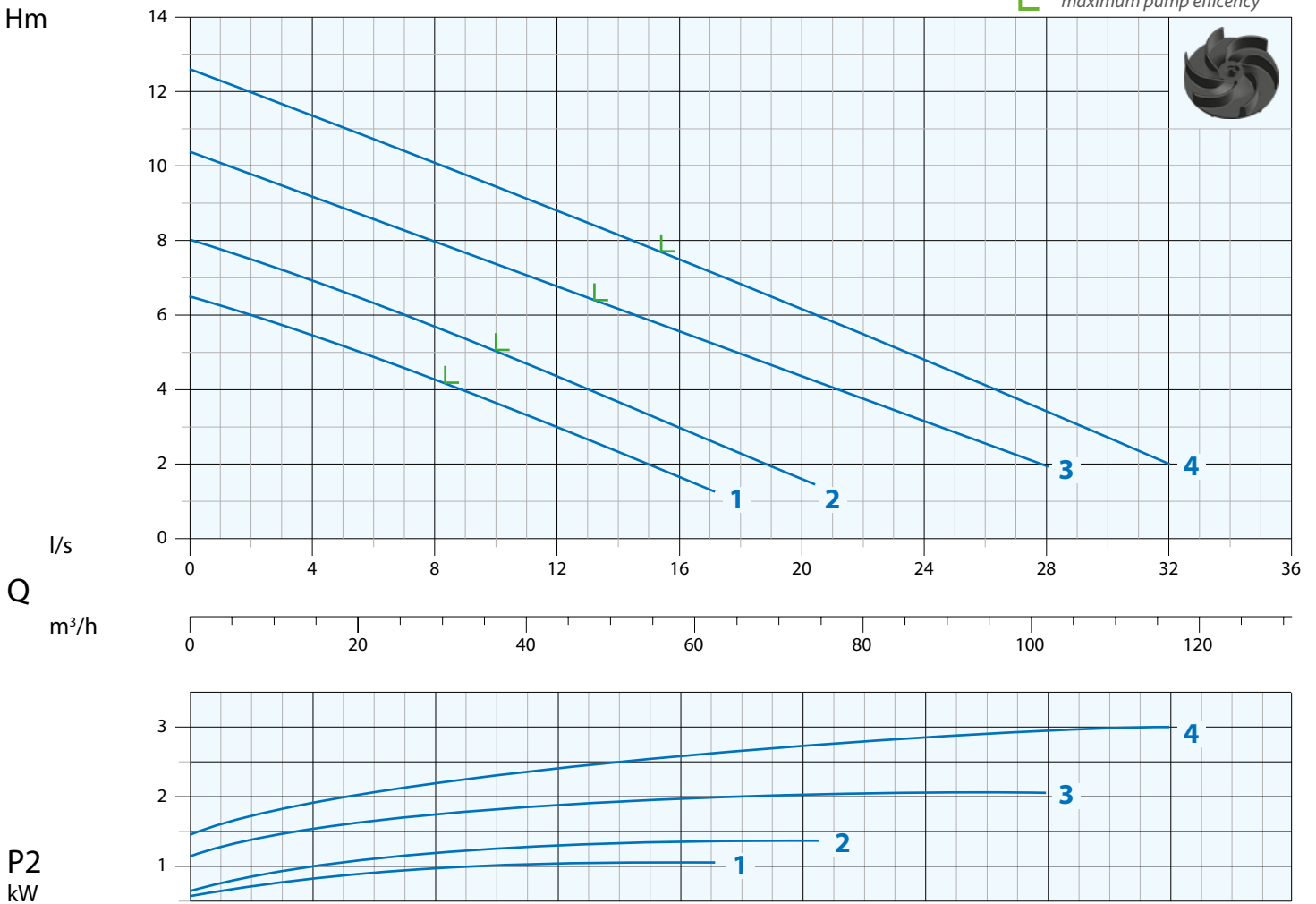

N°	Type	Flow (Q)										
		l/s	2	4	6	8	12	16	20	24	28	32
		l/m	120	240	360	480	720	960	1200	1440	1680	1920
		m³/h	7,2	14,4	21,6	28,8	43,2	57,6	72	86,4	100,8	115,2
1	VM-VT 80/4/125 C.341	mt	6	5,5	5	4,5	3	1,5				
2	VM-VT 80/4/125 C.342		7,5	7	6,5	5,5	4,5	3	1,5			
3	VT 80/4/152 C.344		9,5	9,2	8,5	8	6,8	5,5	4,5	3,2	2	
4	VT 80/4/152 C.345		12	11,5	10,5	10	8,8	7,5	6,2	4,8	3,5	2

N°	Type	EX	Delivery	Free Passage	kW			R.P.M. 1/min	A		Hz
					P1	P2	HP		1 Phase - 230V	µf	
1	VM-VT 80/4/125 C.341	•	DN80 PN16	75 mm	1,3	1,1	1,5	1450	7,3	45	2,8
2	VM-VT 80/4/125 C.342	•			1,7	1,25	1,7		8,7	45	3,3
3	VT 80/4/152 C.344	•			2,8	2,2	3				5,2
4	VT 80/4/152 C.345	•			3,8	3	4				7,2

• Available explosion proof pump

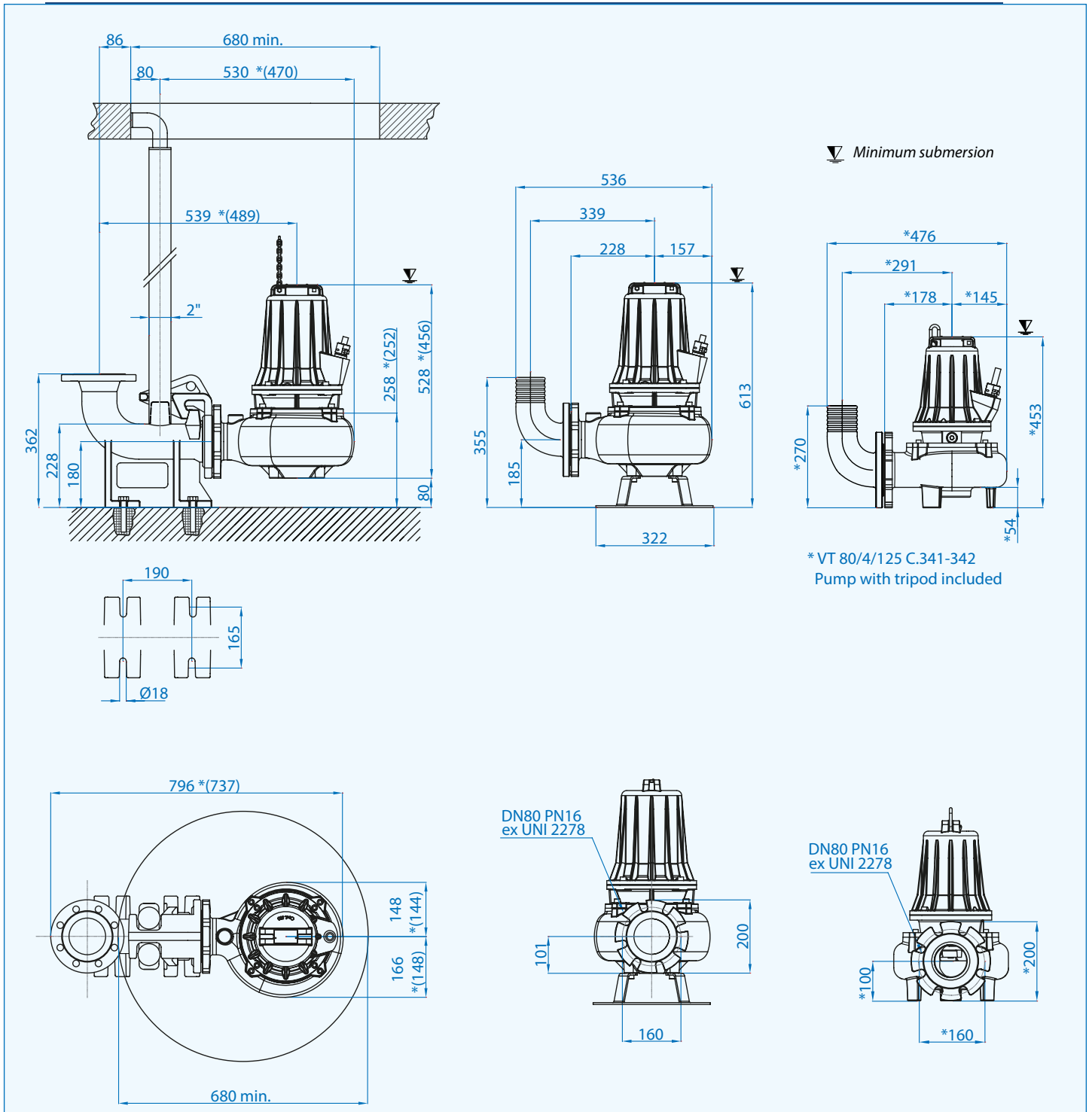

▽ Minimum submersion

\* VT 80/4/125 C.341-342  
Pump with tripod included

### Cables

Pumps	Version	Phases	Cable	Cable cross section mm <sup>2</sup>	mt
80/4/125	Standard	1 ~ 230V	H07RN8F	4x1,5+3x0,50 Ø15*	10
	ATEX		NSSHÖU-J	4x1,5+3x0,50 Ø17*	10
	Standard	3 ~ 400V	H07RN8F	4x1,5+3x0,50 Ø15**	10
	ATEX		D.O.L.	NSSHÖU-J	4x1,5+3x0,50 Ø17**
80/4/152	Standard	3 ~ 400V	H07RN8F	4x1,5+3x0,50 Ø15**	10
	ATEX		D.O.L.	NSSHÖU-J	4x1,5+3x0,50 Ø17**

\* Standard with Control-box (starting capacitor included)

\*\* Free terminals

### Packaging dimension

Type	X mm	Y mm	Z mm	Kg
VM-VT 80/4/125 C.341	355	580	420	48
VM-VT 80/4/125 C.342				48
VT 80/4/152 C.344				65
VT 80/4/152 C.345				66



### Optional



Automatic coupling foot  
Type: DUTY 80 and B5



Flanged hose connection N2 Foot  
support P5 only VT 80/4/152



Stainless steel  
handle



Explosion proof control  
box available on request

Horizontal Outlet DN100 PN16 -  
RPM 1450 1/min 4 poles

Picture for illustration purposes only



### Performance Curve

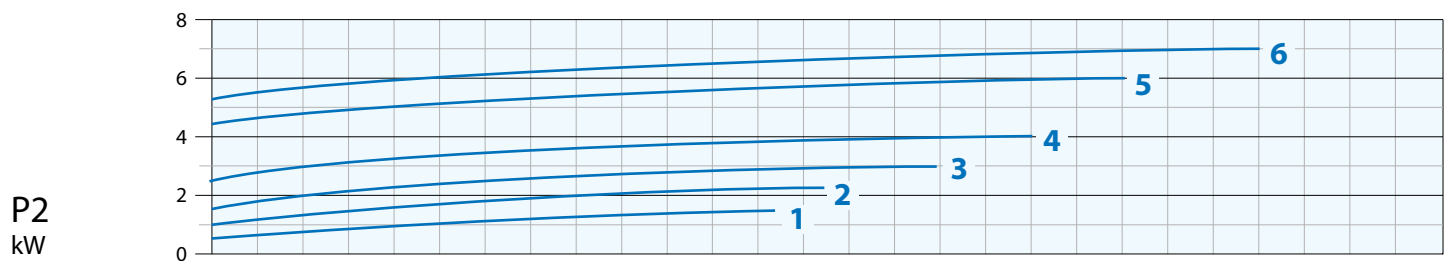
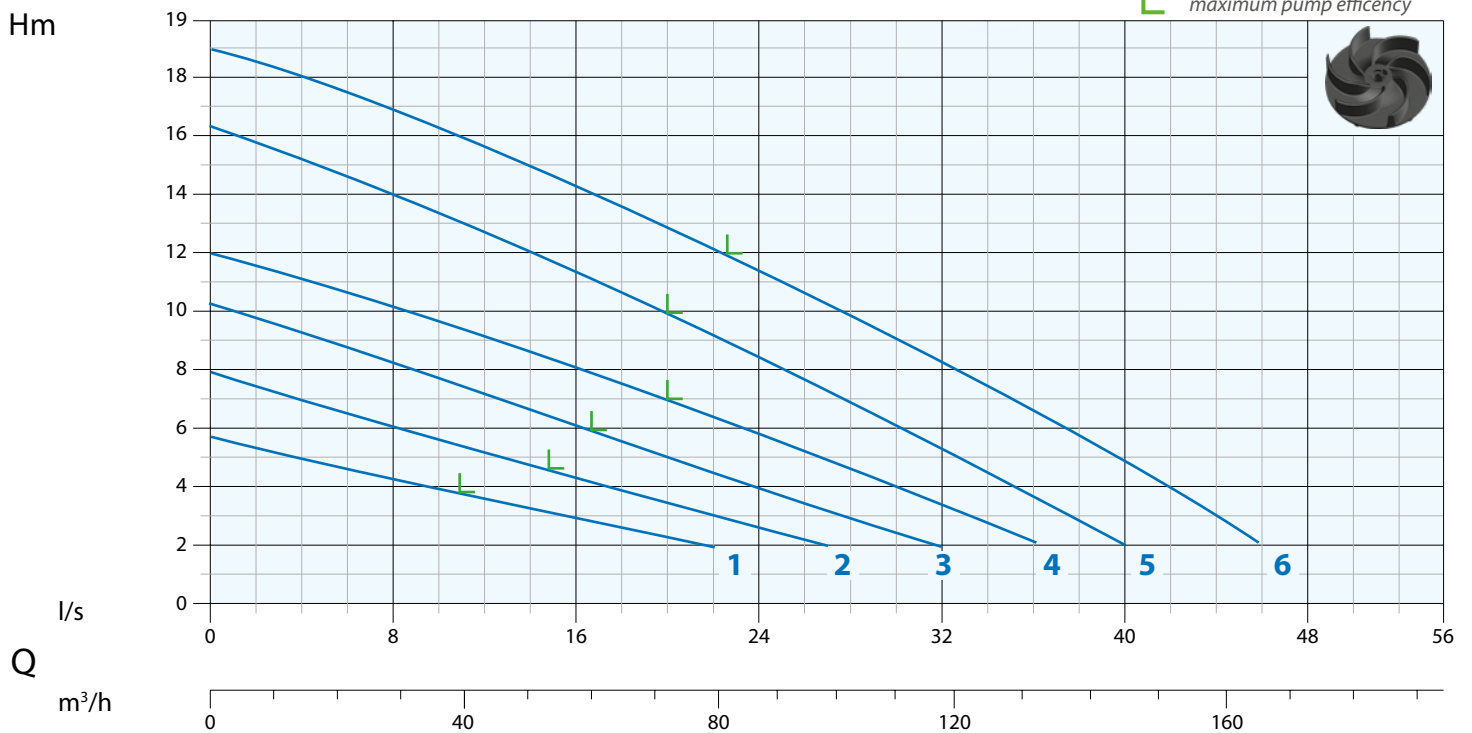

N°	Type	Flow Rate (Q)										
		4	8	12	16	20	24	32	36	40	46	
		l/s	4	8	12	16	20	24	32	36	40	46
		l/m	240	480	720	960	1200	1440	1920	2160	2400	2760
		m³/h	14,4	28,8	43,2	57,6	72	86,4	115,2	129,6	144	165,6
1	VT 100/4/152 C.348	mt	5	4,2	3,5	3	2,2					
2	VT 100/4/152 C.349		7	6	5	4,5	3,5	2,5				
3	VT 100/4/152 C.350		9	8,5	7	6	5	4	2			
4	VT 100/4/173 C.355		11	10	9	8	7	6	3,5	2		
5	VT 100/4/173 C.356		15	14	12,5	11,5	10	8,5	5,5	3,5	2	
6	VT 100/4/173 C.358		18	17	15,5	14,5	13	11,5	8,2	6,5	5	3

N°	Type	EX	Delivery	Free Passage	kW			R.P.M. 1/min	A 3 Phase - 400V	Hz
					P1	P2	HP			
1	VT 100/4/152 C.348	•	DN100 PN16	100 mm	2,2	1,7	2,3	1450	3,9	50
2	VT 100/4/152 C.349	•			3,0	2,2	3		5,2	
3	VT 100/4/152 C.350	•			3,8	3	4		7,2	
4	VT 100/4/173 C.355	•			5,3	4	5,5		9,2	
5	VT 100/4/173 C.356	•			6,9	6	8		12,4	
6	VT 100/4/173 C.358	•			9,0	7,5	10		15,7	

• Available explosion proof pump



EPT 17 ATEX 2702 X



Ex db IIB T4 Gb  
Ex h IIB T4 Gb  
0° Ta 40°

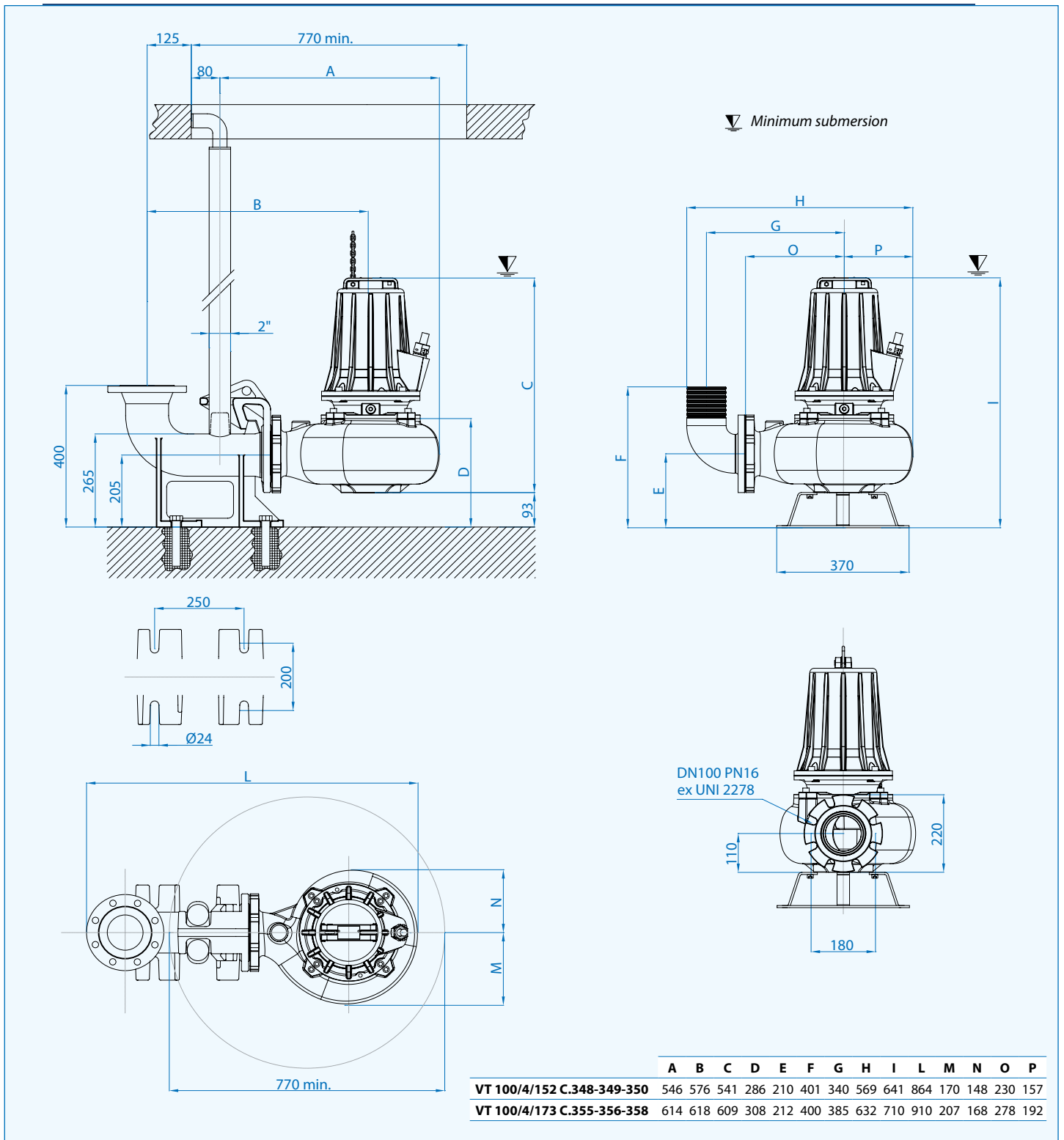

### Cables

Pumps	Version	Phases	Cable	Cable cross section mm <sup>2</sup>	mt
<b>100/4/152</b>	Standard	3 ~ 400V	H07RN8F	4x1,5+3x0,50 Ø15*	10
	ATEX	D.O.L.	NSSHÖU-J	4x1,5+3x0,50 Ø17*	10
<b>100/4/173</b>	Standard	3 ~ 400V	H07RN8F	7x1,5+3x0,50 Ø17*	10
	ATEX	Y-Δ	NSSHÖU-J	7x1,5+3x0,50 Ø17*	10

\* Free terminals

### Packaging dimension

Type	X mm	Y mm	Z mm	Kg
<b>VT 100/4/152 C.348</b>				69
<b>VT 100/4/152 C.349</b>	355	580	420	69
<b>VT 100/4/152 C.350</b>				72
<b>VT 100/4/173 C.355</b>				100,5
<b>VT 100/4/173 C.356</b>	400	620	470	107
<b>VT 100/4/173 C.358</b>				110

### Optional



Automatic coupling foot  
Type: DUTY 100 and B6



Flanged hose connection N3  
Foot support P6



Stainless steel handle

## Submersible electropumps with Vortex impeller

Power:	12÷55 kW
Delivery:	DN100 - 150



### Application

The VT 4 poles Series is used for transport of water with heavy suspended solids. High performance and a wide channel permits its use in industry, including tanneries and farms, and for the movement of water contaminated with soil, or containing large solid pieces.

### Characteristic

All main components are made of grey cast iron GG25. Two individual mechanical seals (motor side in the oil chamber, impeller side in contact with the liquid) and high quality parts, ensure the perfect functioning and reliability of the product.

### Motor range

- Squirrel cage motor 4 poles
- Thermal protection T1 and T2 embedded in the motor winding (to be wired to the three pole contactor in the control panel)
- Class F insulation (155°C)
- IP 68 protection

### Motor cooling

The cooling of the motor is ensured by the liquid where the pump is submerged.

### Limits of use

- Max. permissible liquid temperature: 40°C with pump fully submerged
- On request, special version (excluded ATEX) to withstand liquid temperature up to 60°C with pump fully submerged, no S1 service
- Maximum depth of immersion: 20 mt.
- Permissible pH value: 6-10
- Hydraulic features suitable for liquids with density <math>< 1,1 \text{ kg/dm}^3</math>
- Allowed voltage: 400/690V  $\pm 5\%$
- Allowed frequency: 50Hz  $\pm 2\%$

### Designation

**VT-EX 100 / 4 / 200 C.363**

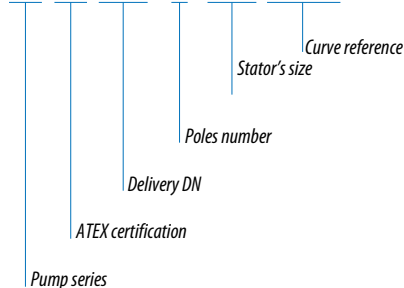

### Performance Overview

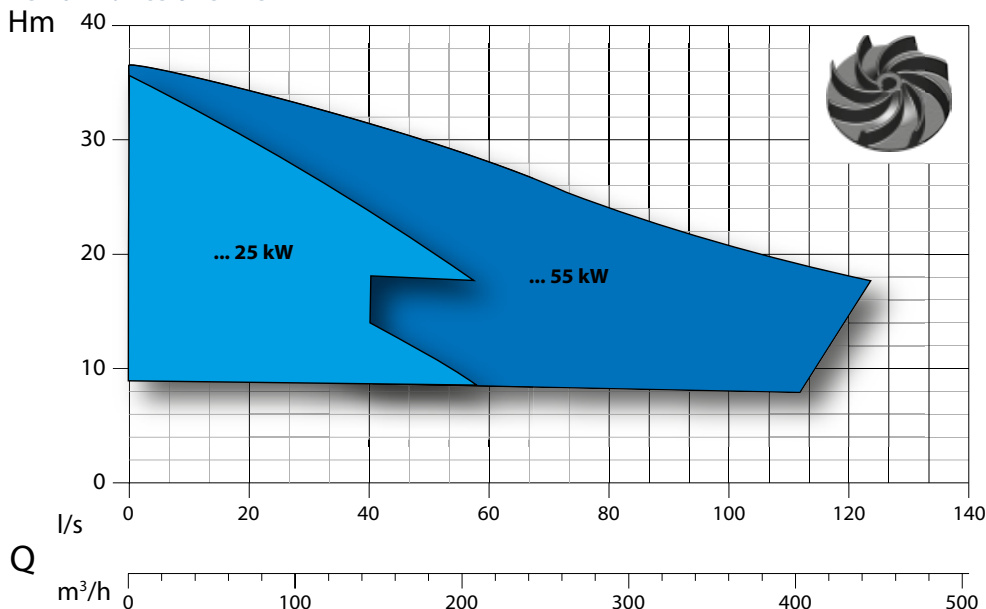

### Curves Identification

- DN100
- DN150

### Norms

According to ISO 9906:2012 3B2

## List of components and materials

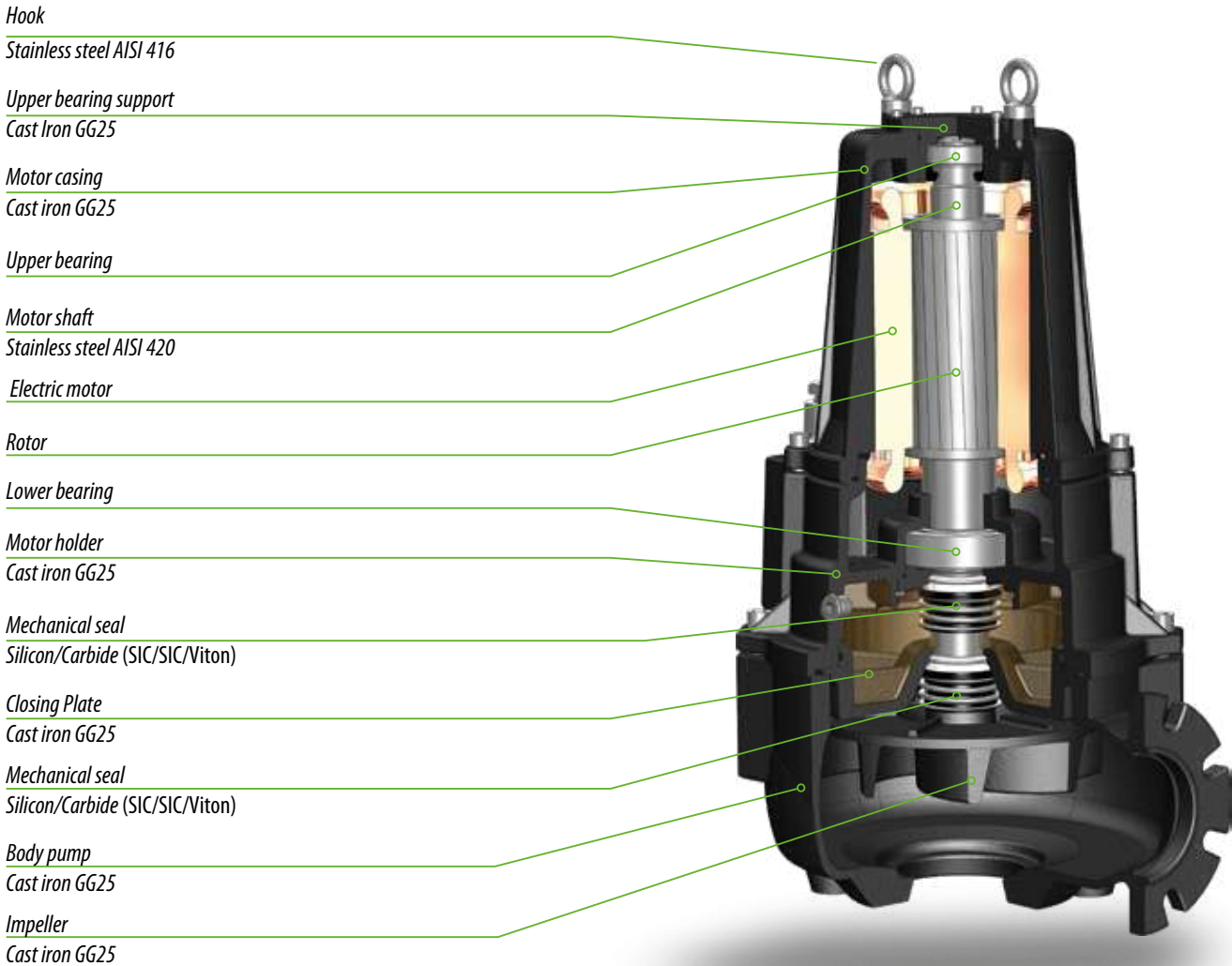

## Technology and Features

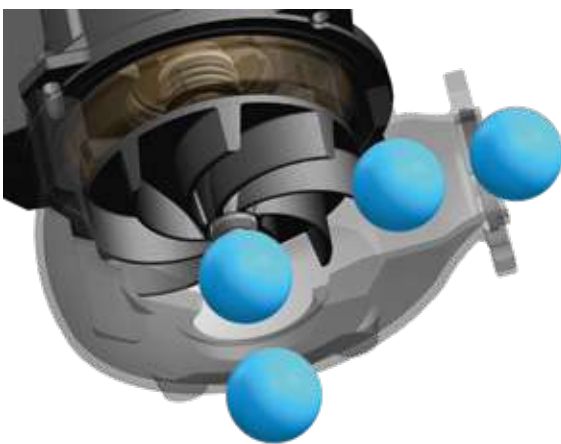

### Impellers

Impellers have been studied to grant excellent performances and ample solid handling.



### Explosion proof pumps



II 2G Ex db IIB T4 Gb  
Ex h IIB T4 Gb  
0° ~ Ta ~ 40°



EPT 17 ATEX 2703 X

These certificates grant for the safe use of the product in hazardous area in line with the stringent European and International standards ATEX/IECEx.



### Seal leak detector

The seal leak detector is certified according to the norm EN 60079-0, EN 60079-1 (through safety barrier). Standard on all series (not applicable with IECEx).



### Bearings

The series is fitted with a cylindrical roller bearing (upper bearing) to absorb the thrust and vibration generated by the pump shaft.

### Horizontal Outlet DN100 PN16 - RPM 1450 1/min 4 poles

Picture for illustration purposes only



### Performance Curve

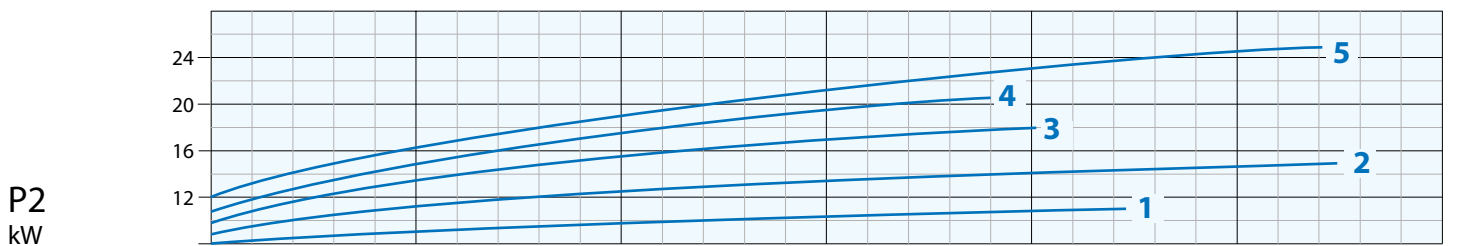
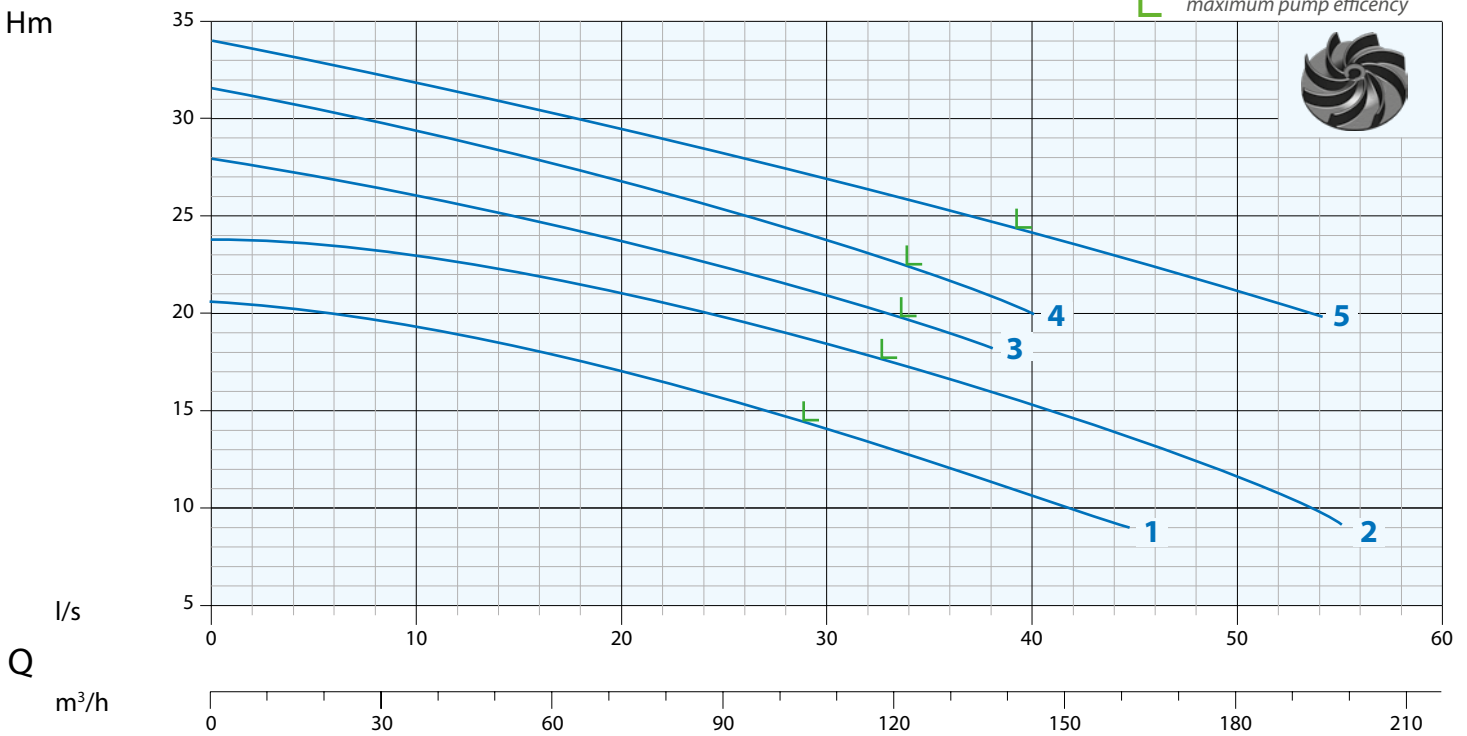

N°	Type	EX			Q												
			Delivery	Free Passage	6	10	14	20	24	30	34	40	50	54			
					l/s	360	600	840	1200	1440	1800	2040	2400	3000	3240		
					l/m	21,6	36	50,4	72	86,4	108	122,4	144	180	194,4		
					m³/h	20	19	18,5	17	16	14	13	10,5				
1	VT 100/4/200 C.362	•	DN100 PN16	100 mm	mt	23,5	23	22	21	20	18,5	17	15,5	11,5	10		
2	VT 100/4/200 C.363	•				27	26	25	23,5	22,5	21	19,5	17,5				
3	VT 100/4/240 C.370	•				30	29	28,5	27	25,5	24	22,5	20				
4	VT 100/4/240 C.375	•				33	32	31	29,5	28,5	27	26	24	21	20		
5	VT 100/4/240 C.380	•															

N°	Type	EX	Delivery	Free Passage	kW			R.P.M. 1/min	A		Hz
					P1	P2	HP		3 Phase - 400V		
1	VT 100/4/200 C.362	•	DN100 PN16	100 mm	13,0	11,5	16	1450	23,8		50
2	VT 100/4/200 C.363	•			17,3	15	21		30,4		
3	VT 100/4/240 C.370	•			21	18	24,5		38,7		
4	VT 100/4/240 C.375	•			22,4	20	27		41		
5	VT 100/4/240 C.380	•			28,5	25	34		50,9		

• Available explosion proof pump with certifications:



Ex db IIB T4 Gb  
Ex h IIB T4 Gb  
0° Ta ~ 40°

EPT 17 ATEX 2703 X

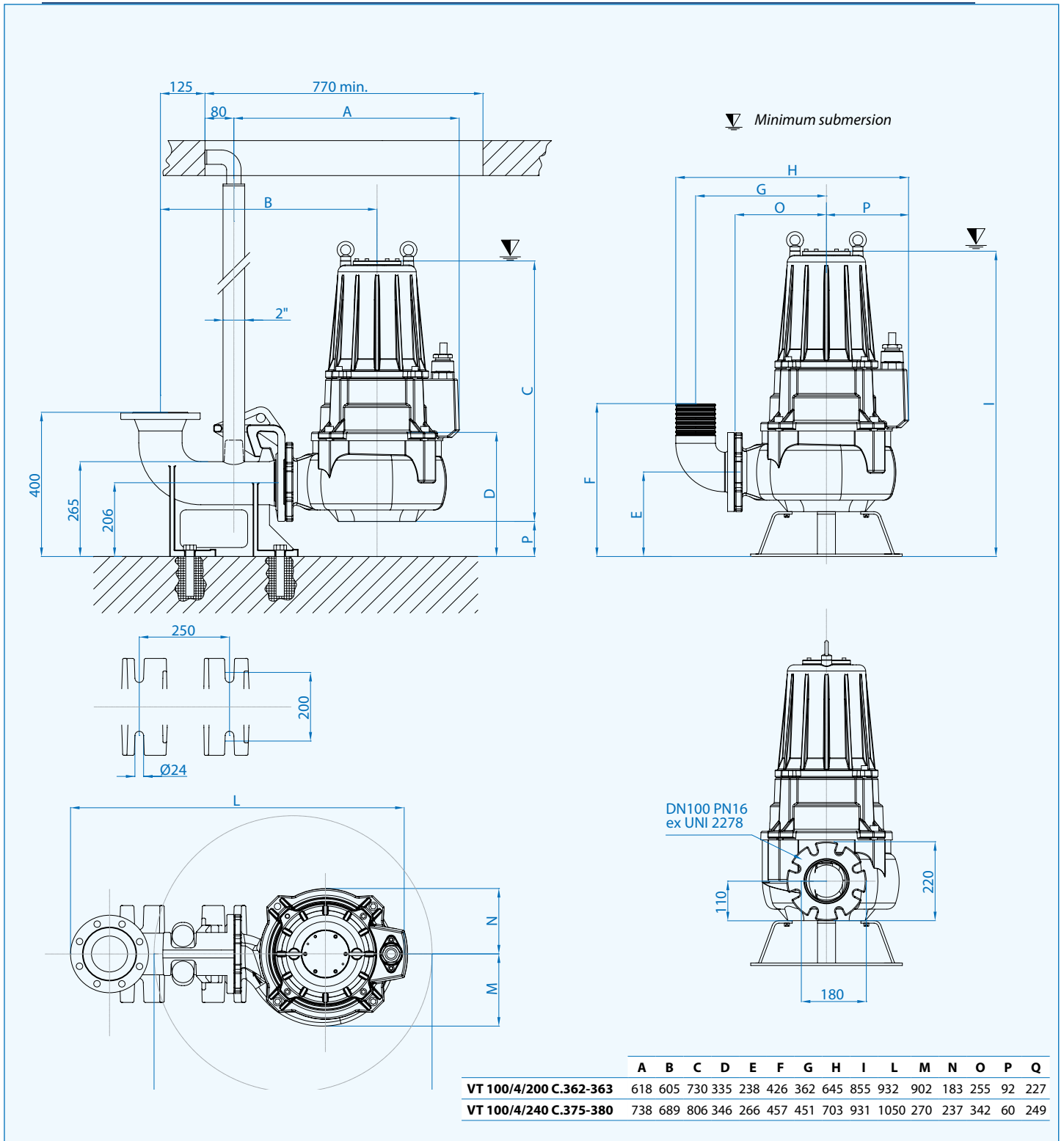

### Cables

Pumps	Version	Phases	Cable	Cable cross section mm <sup>2</sup>	mt
<b>VT 100/4/200</b>	Standard	3 ~ 400V	H07RN8F	10x2,5 Ø23*	10
	ATEX	Y-Δ	NSSHÖU-J	7x2,5+3x0,50 Ø20*	10
<b>VT 100/4/240</b>	Standard	3 ~ 400V	H07RN8F	7x4+3x1 Ø20,5*	10
	ATEX	Y-Δ	NSSHÖU-J	7x6+3x1 Ø24*	10

\* Free terminals

### Packaging dimension

Type	X mm	Y mm	Z mm	Kg
<b>VT 100/4/200 C.362</b>	510	860	420	197
<b>VT 100/4/200 C.363</b>				210
<b>VT 100/4/240 C.370</b>				274
<b>VT 100/4/240 C.375</b>	570	950	670	275
<b>VT 100/4/240 C.380</b>				280

### Optional



Automatic coupling foot  
Type: DUTY 100 and B6

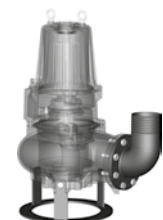

Flanged hose connection N3  
Foot support P7



### Horizontal Outlet DN150 PN16 - RPM 1450 1/min 4 poles

Picture for illustration purposes only



### Performance Curve

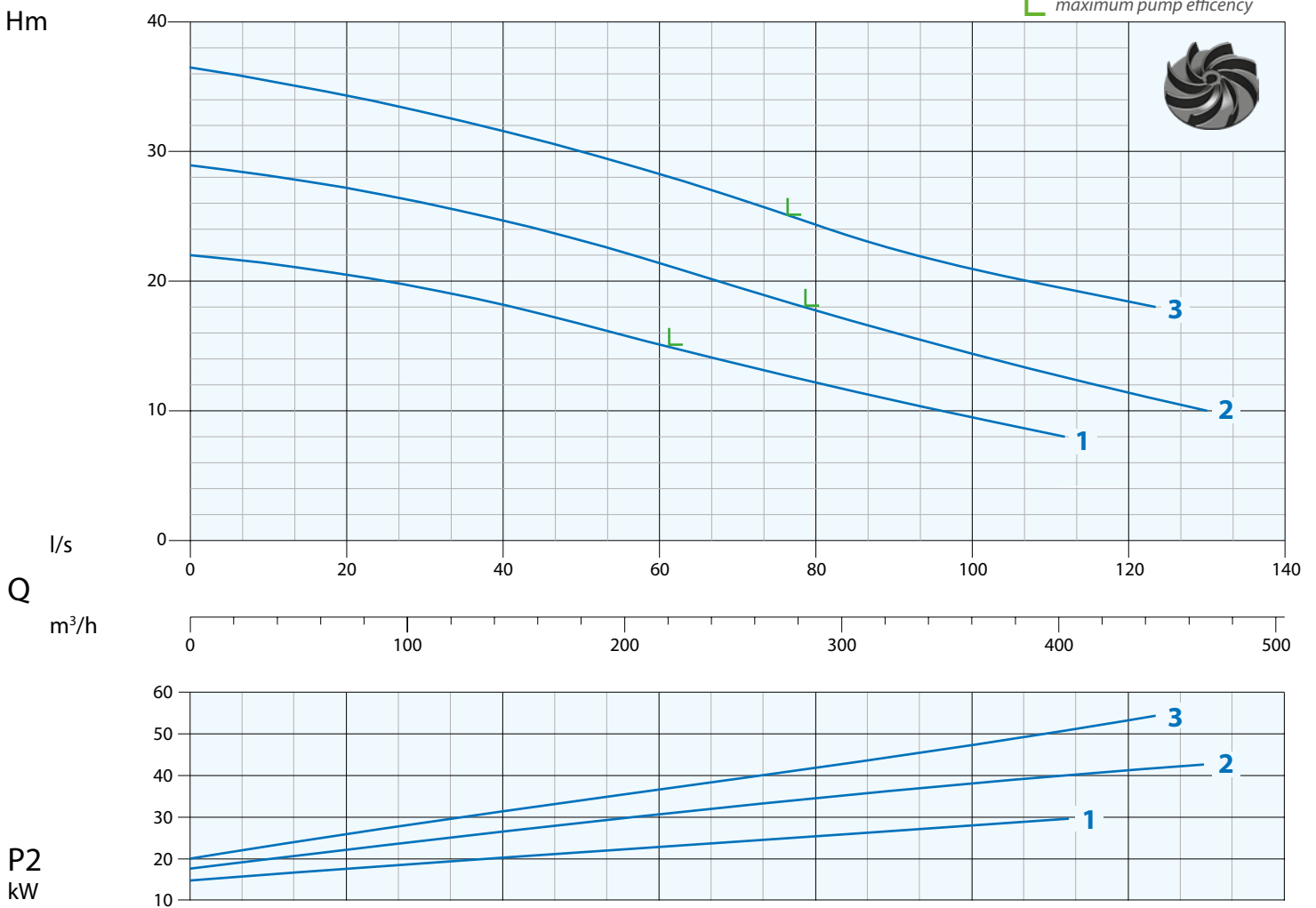

N°	Type	l/s	10	20	30	40	50	60	80	100	110	120
			l/m	600	1200	1800	2400	3000	3600	4800	6000	6600
		m³/h	36	72	108	144	180	216	288	360	396	432
1	VT 150/4/340 C.385	mt	21,5	20,5	19,5	18	16,5	15	12	9,5	8	
2	VT 150/4/340 C.390		28	27,5	26	25	23	21,5	18	14	13	11,5
5	VT 150/4/340 C.395		35	34	33	31,8	30	28	24	21	19,5	18,2

N°	Type	Delivery	Free Passage	kW		HP	R.P.M. 1/min	A		Hz
				P1	P2			3 Phase - 400V		
1	VT 150/4/340 C.385			38	37	48		68		
2	VT 150/4/340 C.390	DN150 PN16	130 mm	49,4	45	61	1450	82,5		50
5	VT 150/4/340 C.395			58,9	54,5	75		100,1		

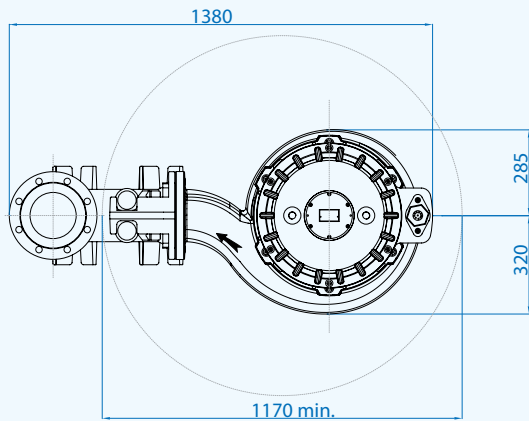
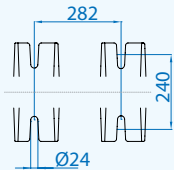
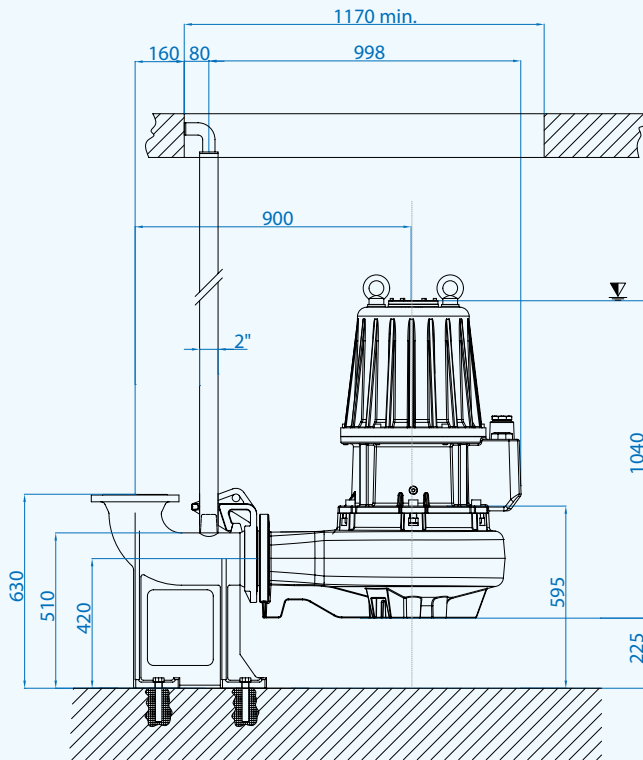

▽ Minimum submersion

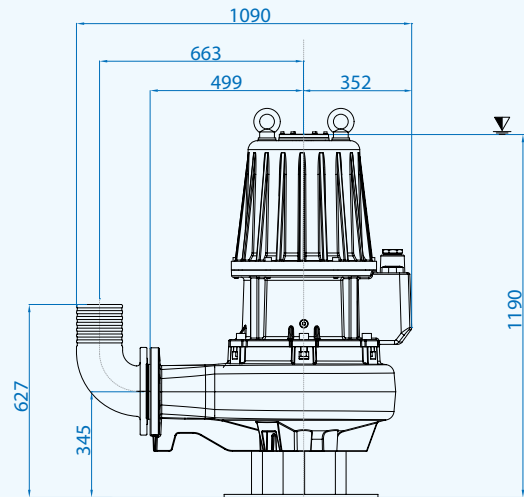

DN150 PN16  
ex UNI 2278

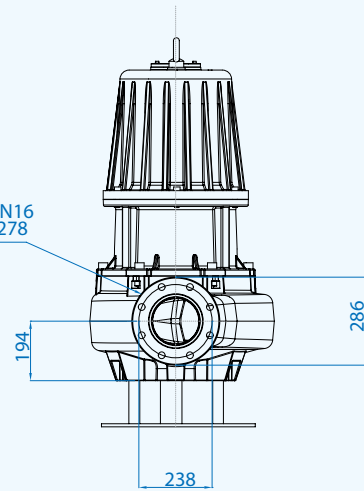

### Cables

Version	Phases	Cable	Cable cross section mm <sup>2</sup>	mt
Standard	3 ~ 400V Y-Δ	H07RN8F	7x10+5x1 Ø29*	10

\* Free terminals

### Packaging dimension

Type	X mm	Y mm	Z mm	Kg
VT 150/4/340 C.385				550
VT 150/4/340 C.390	980	1310	730	585
VT 150/4/340 C.395				590



### Optional



Automatic coupling foot  
Type: B8

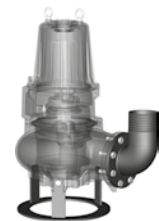

Flanged hose connection N4  
Foot support P8

## Submersible electropumps with S-Flow double channel impeller

Power:	<b>0.8÷2.2 kW</b>
Delivery:	<b>DN 65 - 80</b>



### Application

The DNB series is used for pumping and draining clear liquid and sewage. The special S-Flow channels impeller permits the passage of short solid fibrous and is particularly suitable for wastewater and sewage treatment plants. The 4 poles versions can be used in application where continuous service is needed and are characterized by their quiet operation.

### Characteristic

The main components are realised in cast iron GG20. The Double mechanical seals in a back to back configuration located in the oil chamber guarantee long durability to the product.

### Motor range

- Squirrel cage motor in 2 and 4 pole version
- Thermal protection embedded in the winding (In the DNB ...-2/220 and DNB 4 poles model the thermal protection T1 and T2 conductor to be wired to the control panel)
- Insulation class F 155°C
- Motor protection IP 68

### Motor cooling

The cooling of the motor is ensured by the liquid where the pump is submerged.

### Limits of use

- Max. permissible liquid temperature: 40°C with pump fully submerged
- Maximum depth of immersion: 20 mt.
- Permissible pH value: 6-10
- Hydraulic features suitable for liquids with density <math>< 1,1 \text{ kg/dm}^3</math>
- Allowed voltage: 230V-400V  $\pm 5\%$
- Allowed frequency: 50Hz  $\pm 2\%$

### Designation

**DNB EX 80 - 2 / 150 M/T G**

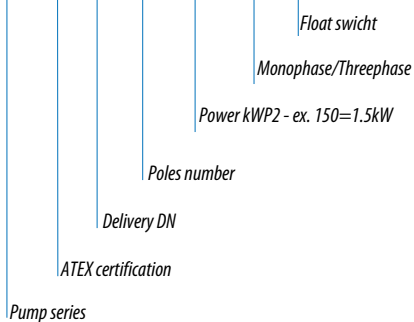

### Performance Overview

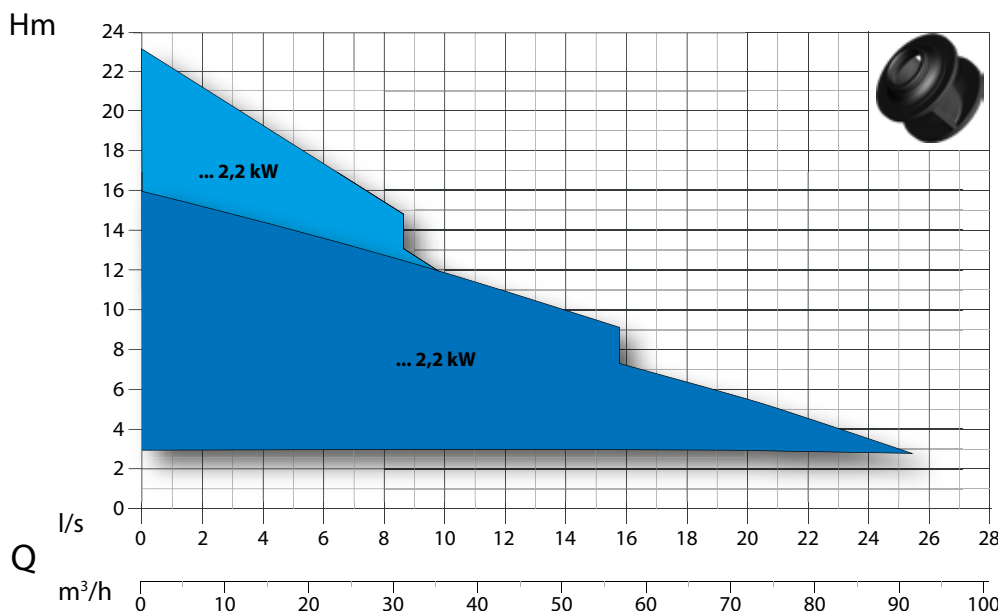

### Curves Identification

- DN65
- DN80

### Norms

According to ISO 9906 level 2

## List of components and materials

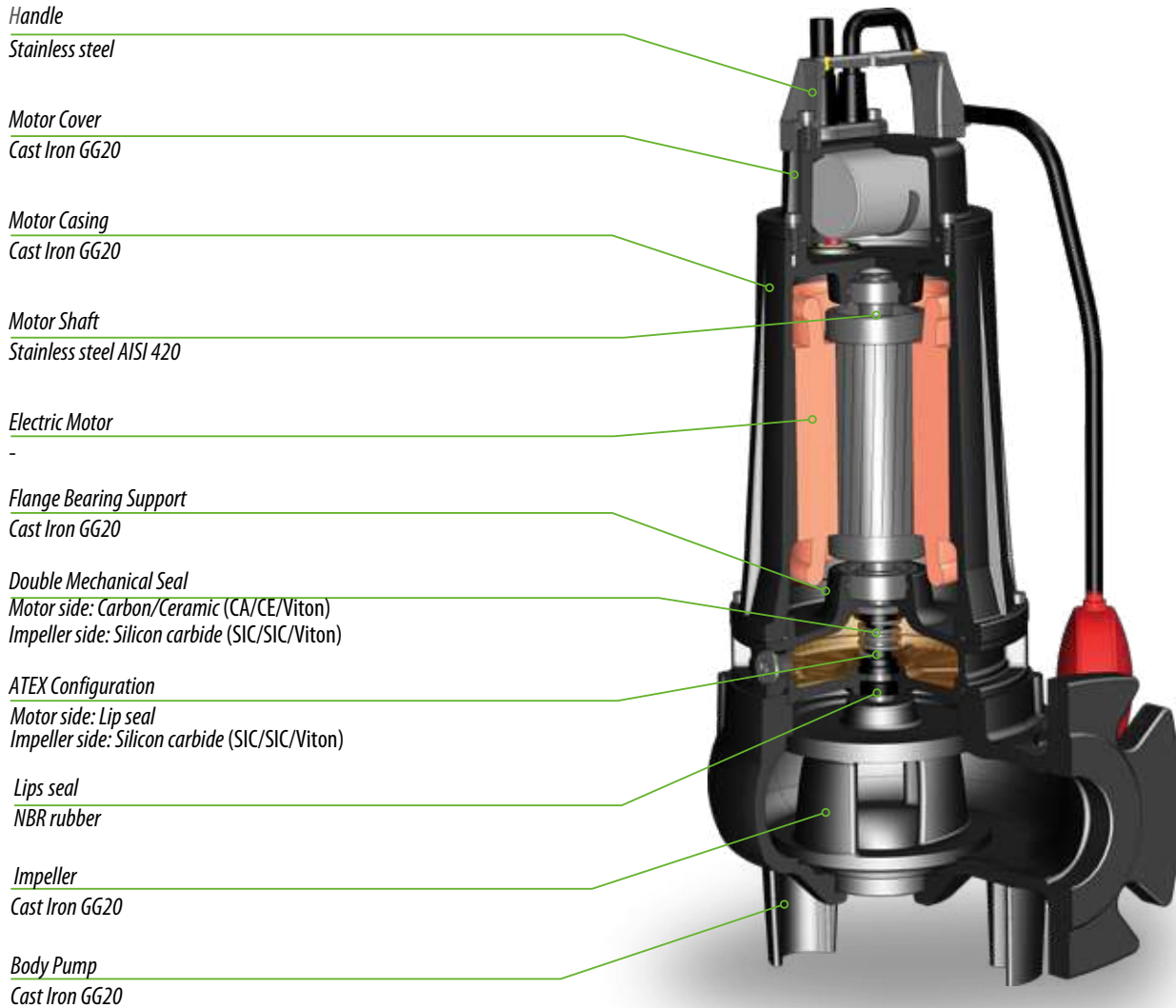

## Technology and Features



### S-Flow impellers

The Superior efficiency of the S-Flow Impeller guarantees excellent performances, with wide solid bodies passage and with low power pumps.



### Explosion proof pumps

Pumps with explosion proof available on request.



EPT 17 ATEX 2701 X



II 2G

Ex db IIB T4 Gb  
Ex h IIB T4 Gb  
0° ~ Ta ~ 40°



### Relay

For the correct operating of the float switch on the three-phase version, up to 1,5 kW 2 poles. ATEX excluded.



### Inspectional Oil Chamber

Excellent lubrication of the mechanical seals even in the harshest pumping conditions. The presence of a lip seal ensure the maximum seal in case of oil leakage.

## Horizontal Outlet DN65 PN10 - RPM 2850 1/min 2 poles

Picture for illustration purposes only



### Performance Curve

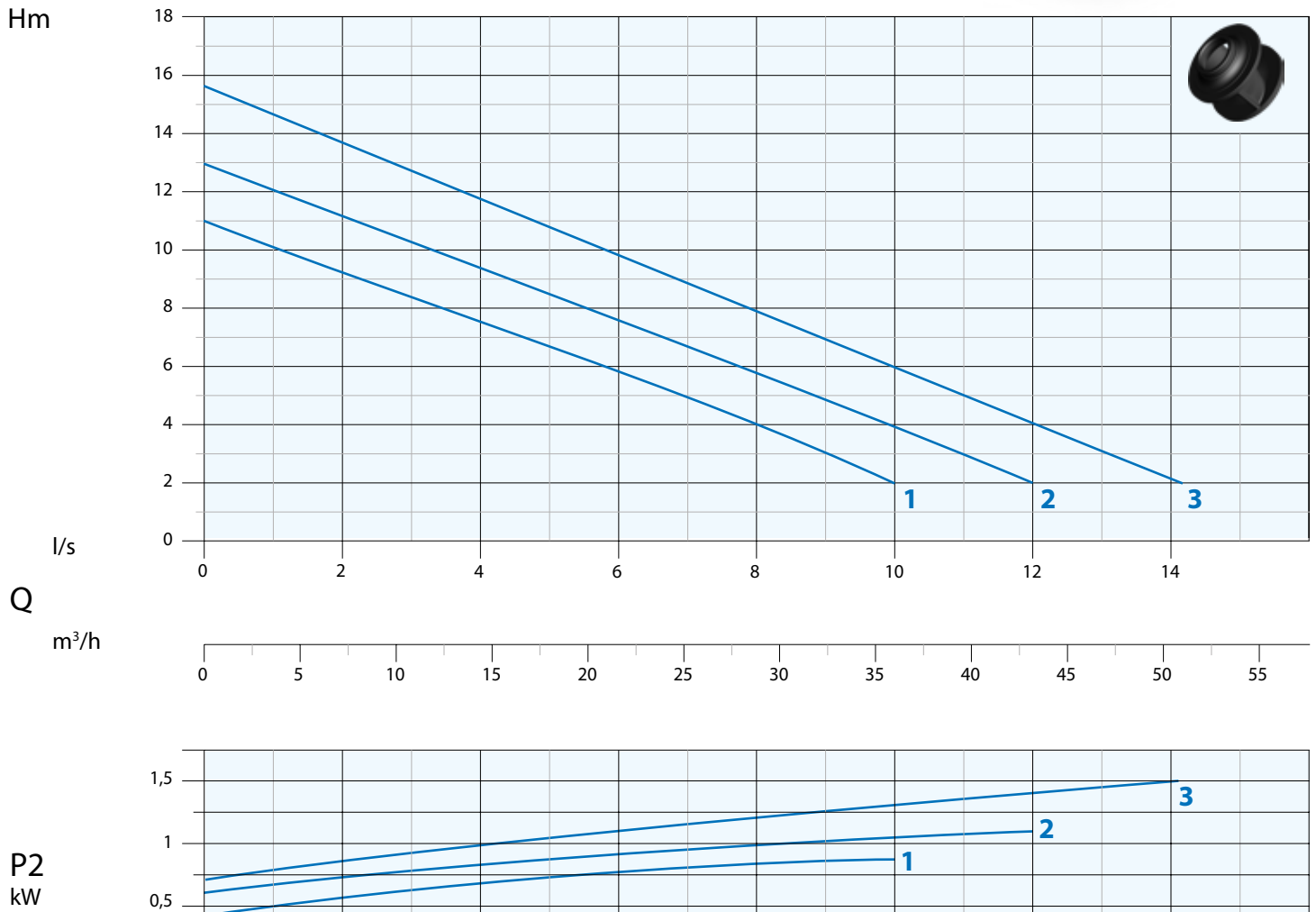

N°	Type		l/s	1	2	4	6	8	10	11	12	14
			l/m	60	120	240	360	480	600	660	720	840
			m³/h	3,6	7,2	14,4	21,6	28,8	36,0	39,6	43,2	50,4
1	DNB 65-2/080 M/T	mt		10	9	7,5	5,5	3,5	2			
2	DNB 65-2/110 M/T			12,5	11,5	9,5	7,5	5,5	4	3		
3	DNB 65-2/150 M/T			15	14	12	10	8	6	5	4	2

N°	Type	EX	Delivery	Free Passage	kW		HP	R.P.M. 1/min	A		Hz	
					P1	P2			1 Phase - 230V	µf		3 Phase - 400V
1	DNB 65-2/080 M/T	•	DN65 PN10 - G 2"	50 mm	1,1	0,8	1,5	2850	5,2	18	2,1	50
2	DNB 65-2/110 M/T	•			1,5	1,1	2		7,5	30	2,8	
3	DNB 65-2/150 M/T	•	DN65 PN10		2,0	1,5	3		9,9	32	3,7	

• Available explosion proof pump

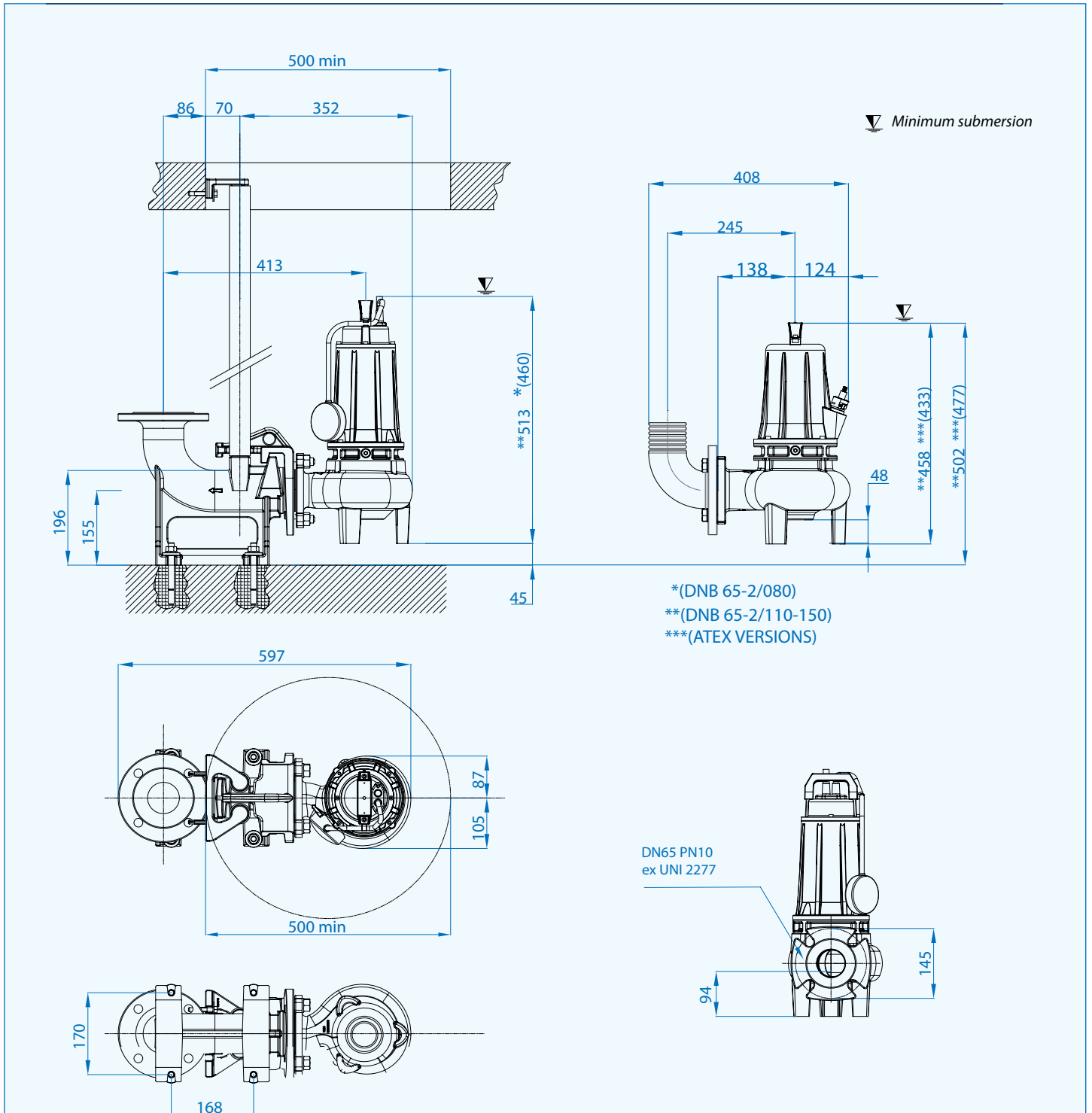

## Cables

Version	Phases	Cable	Cable cross section mm <sup>2</sup>	mt
Standard	1 ~ 230V	H07RN8F	3x1 Ø9*	10
	3 ~ 400V		4x1 Ø10***	10
Versioni/Versions ATEX	1 ~ 230V	NSSHÖU-J	4x1,5+2x0,50 Ø12**	10
	3 ~ 400V		4x1,5+2x0,50 Ø12***	10

- \* Schuko plug
- \*\* Control box
- \*\*\* Free terminals

## Packaging dimensions

Type	X mm	Y mm	Z mm	Kg
DNB 65-2/080 M/T				21
DNB 65-2/110 M/T	206	585	313	29
DNB 65-2/150 M/T				31

## Optional



Explosion proof control box available on request



### Horizontal Outlet DN65 PN10 - RPM 2850 1/min 2 poles

Picture for illustration purposes only



#### Performance Curve

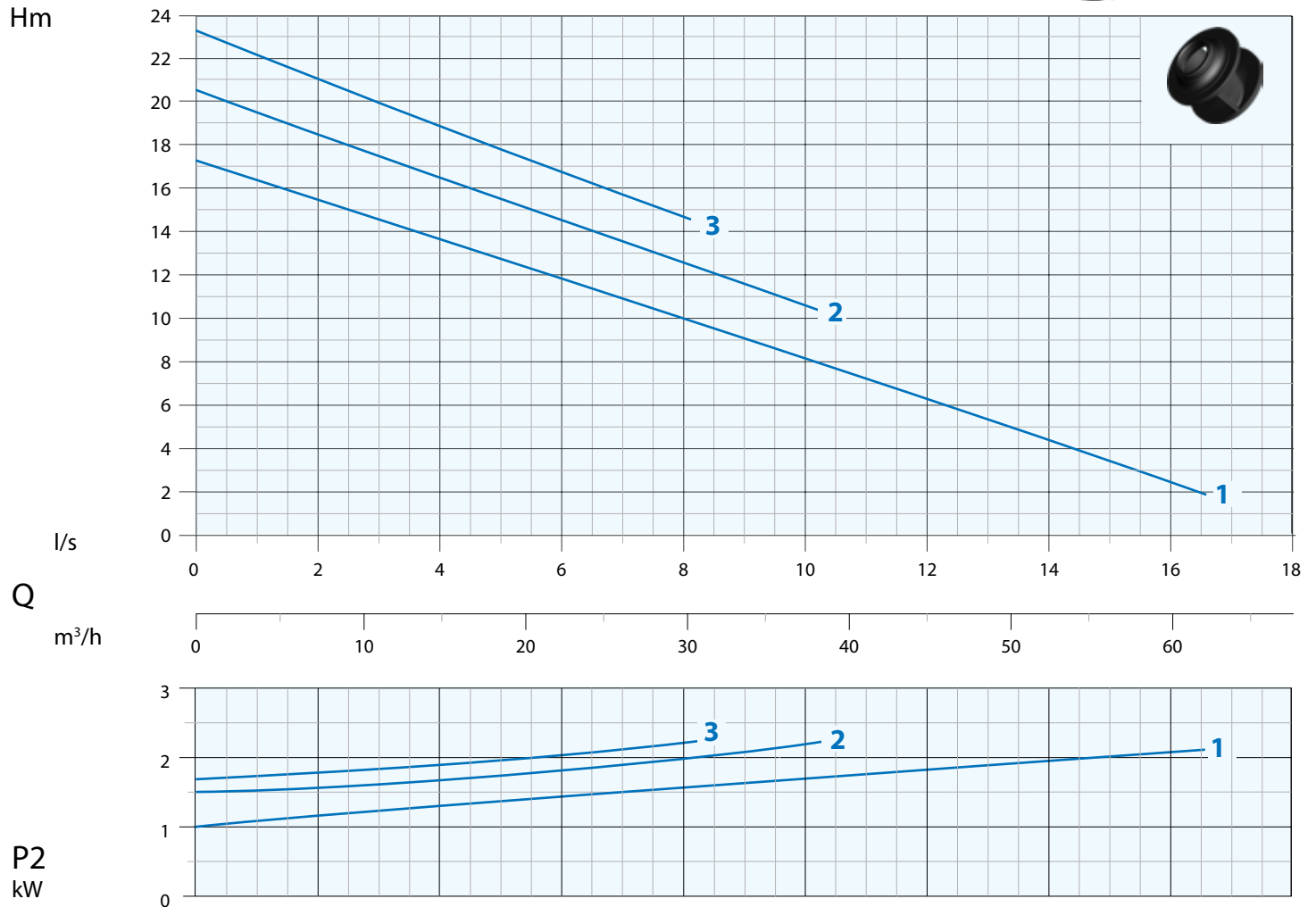

N°	Type	l/s	1	2	3	4	6	8	10	12	14	16
		l/m	60	120	180	240	360	480	600	720	840	960
		m³/h	3,6	7,2	10,8	14,4	21,6	28,8	36	43,2	50,4	57,6
1	DNB 65-2/220 T		17,5	16,5	15,5	14,5	12,5	10,5	8,5	6,5	4,5	2,5
2	DNB 65-2/220-1 T		20	19	18	17	14,5	12,5	10,5			
3	DNB 65-2/220-2 T		22,5	21	20	19	17	14,5				

N°	Type	EX	Delivery	Free Passage	kW		HP	R.P.M. 1/min	3 Phase - 400V	Hz
					P1	P2				
1	DNB 65-2/220 T	•			2,5	2,2	3		5	
2	DNB 65-2/220-1 T	•	DN65 PN10	50 mm	2,9	2,2	3	2850	5,3	50
3	DNB 65-2/220-2 T	•			3	2,2	3		5,3	

• Available explosion proof pump

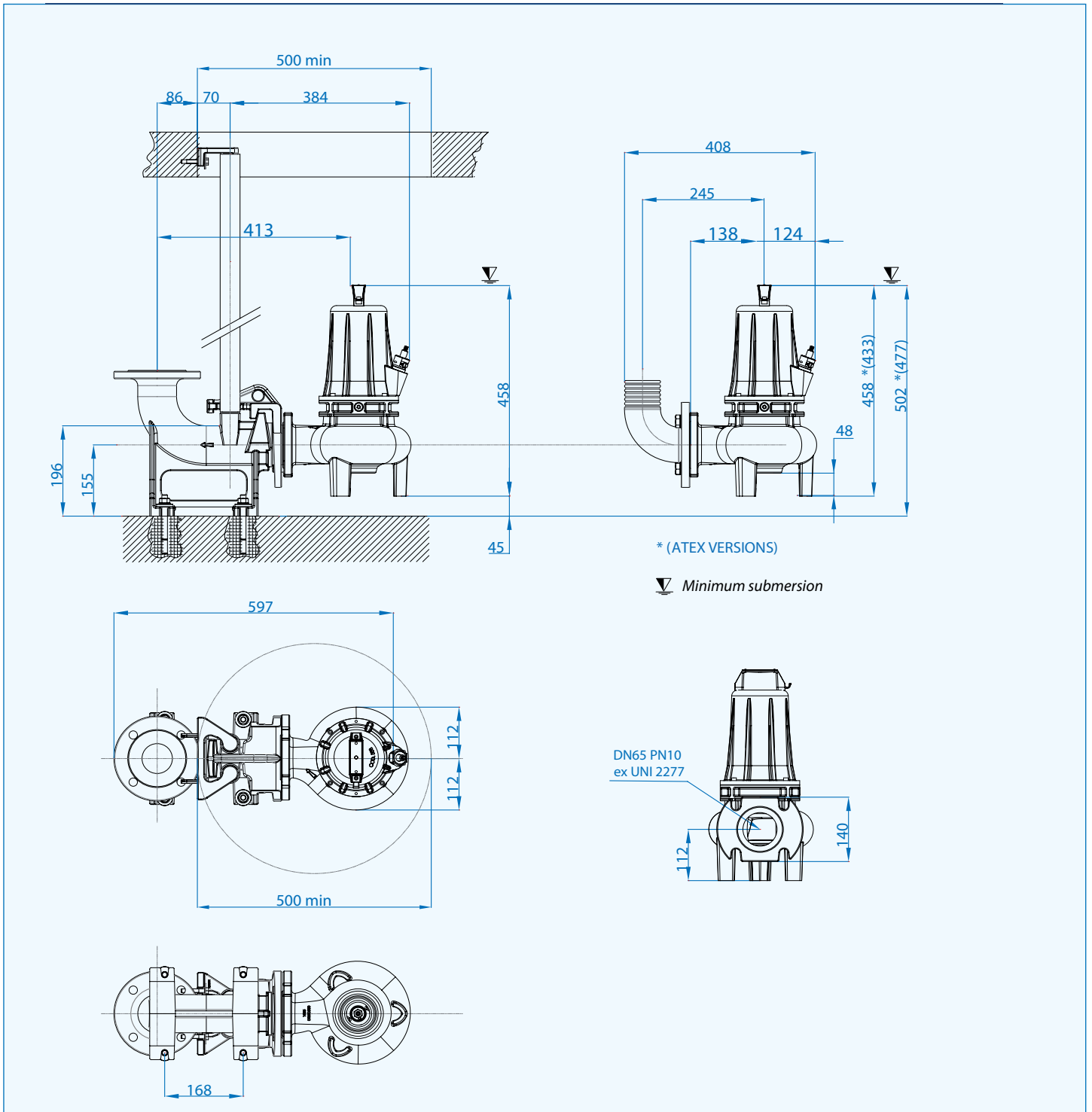

### Cables

Version	Phases	Cable	Cable cross section mm <sup>2</sup>	mt
Standard	3 ~ 400V	H07RN8F	4x1,5+2x0,50 Ø12*	10
Versioni/Versions ATEX	3 ~ 400V	NSSHÖU-J	4x1,5+2x0,50 Ø14*	10

\* Free terminals

### Packaging dimensions

Type	X mm	Y mm	Z mm	Kg
DNB 65-2/220 T				35
DNB 65-2/220-1 T	206	585	313	36
DNB 65-2/220-2 T				36

### Optional



Explosion proof control box available on request



For single phase pumps:  
Control-box with external main capacitor



Automatic coupling foot  
Type: DUTY 65-B4/PN10



Flanged hose connection N5



### Horizontal Outlet DN80 PN16 - RPM 2850 1/min 2 poles

Picture for illustration purposes only



#### Performance Curve

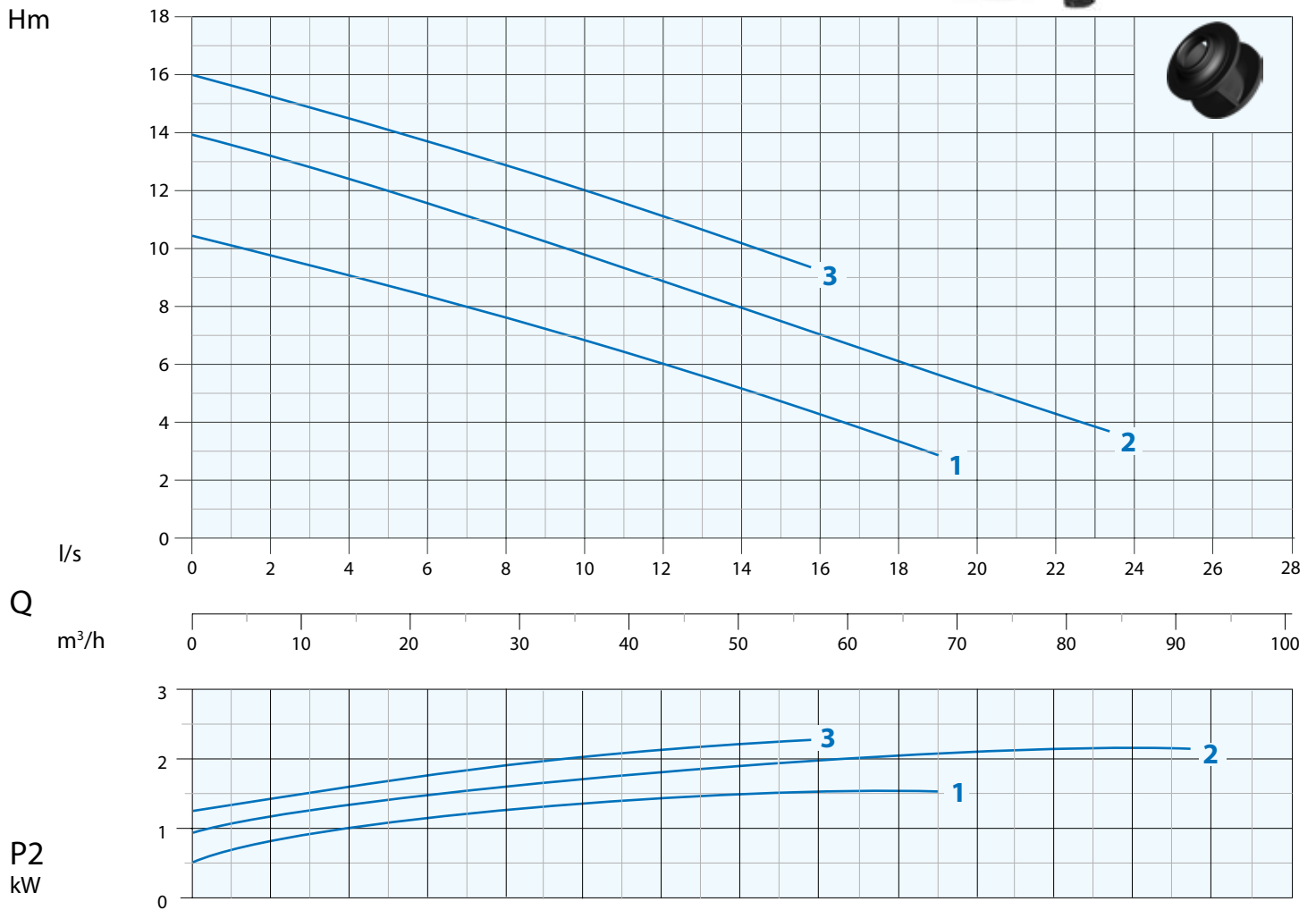

N°	Type	Flow Rate (m³/h)														
		2	4	6	8	10	12	14	16	18	20	22	24	25		
		l/s	l/m	m³/h	7,2	14,4	21,6	28,8	36	43,2	50,4	57,6	64,8	72	79,2	86,4
1	DNB 80-2/150 M/T	9,5	9	8,5	7,5	7	6	5	4,5	3,5						
2	DNB 80-2/220 T	13	12,5	11,5	10,5	9,5	9	8	7	6,5	5,5	4,5	3,5	3		
3	DNB 80-2/220-1 T	15	14,5	13,5	13	12	11	10	9,5							

N°	Type	EX	Delivery	Free Passage	kW		HP	R.P.M. 1/min	A		Hz
					P1	P2			1 Phase - 230V	3 Phase - 400V	
2	DNB 80-2/150 M/T	•			2,1	1,5	2		9,9	32	3,7
3	DNB 80-2/220 T	•	DN80 PN16	70 mm	2,9	2,2	3	2850	-	-	5,5
4	DNB 80-2/220-1 T	•			2,9	2,2	3		-	-	5,3

• Available explosion proof pump

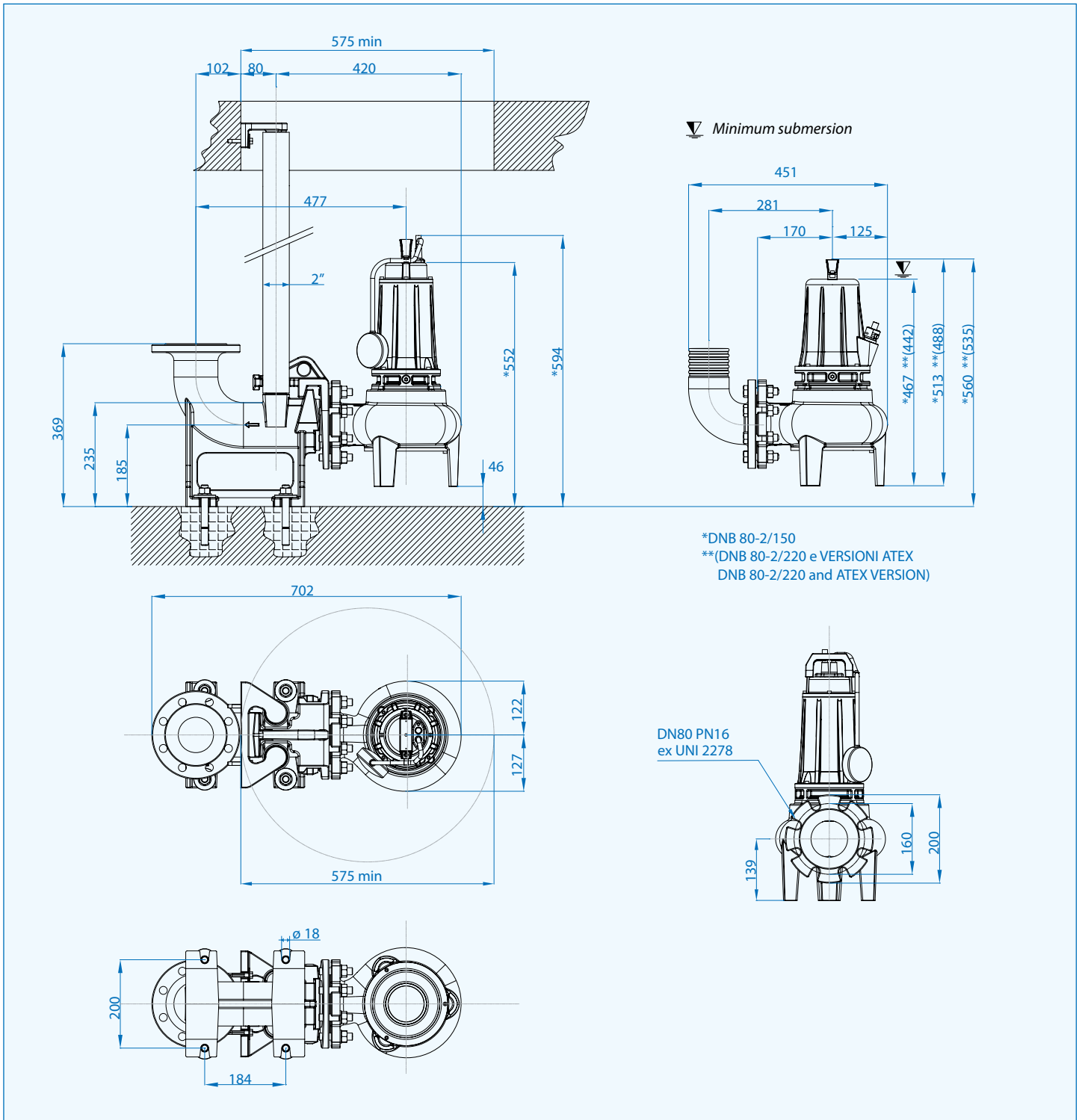

### Cables

Pumps	Phases	Cable	Cable cross section mm <sup>2</sup>	mt
DNB 80-2/150	1 ~ 230V	H07RN8F	3x1 Ø9*	10
	3 ~ 400V		4x1 Ø10***	10
DNB 80-2/220 (-1)	3 ~ 400V	H07RN8F	4x1,5+2x0,50 Ø12***	10
Versioni/Versions ATEX	1 ~ 230V	NSSHÖU-J	4x1,5+2x0,50 Ø12**	10
	3 ~ 400V		4x1,5+2x0,50 Ø12***	10

\* Schuko plug  
 \*\* Control box

\*\*\* Free terminals

### Packing dimensions

Type	X mm	Y mm	Z mm	Kg
DNB 80-2/150 M/T	206	585	313	35
DNB 80-2/220 T				36
DNB 80-2/220-1 T				35

### Optional



Explosion proof control box available on request



For single phase pumps:  
 Control-box with external main capacitor



Automatic coupling foot  
 Type: DUTY 80 and B5



Flanged hose connection N2

### Horizontal Outlet DN80 PN16 - RPM 1450 1/min 4 poles

Picture for illustration purposes only



### Performance Curve

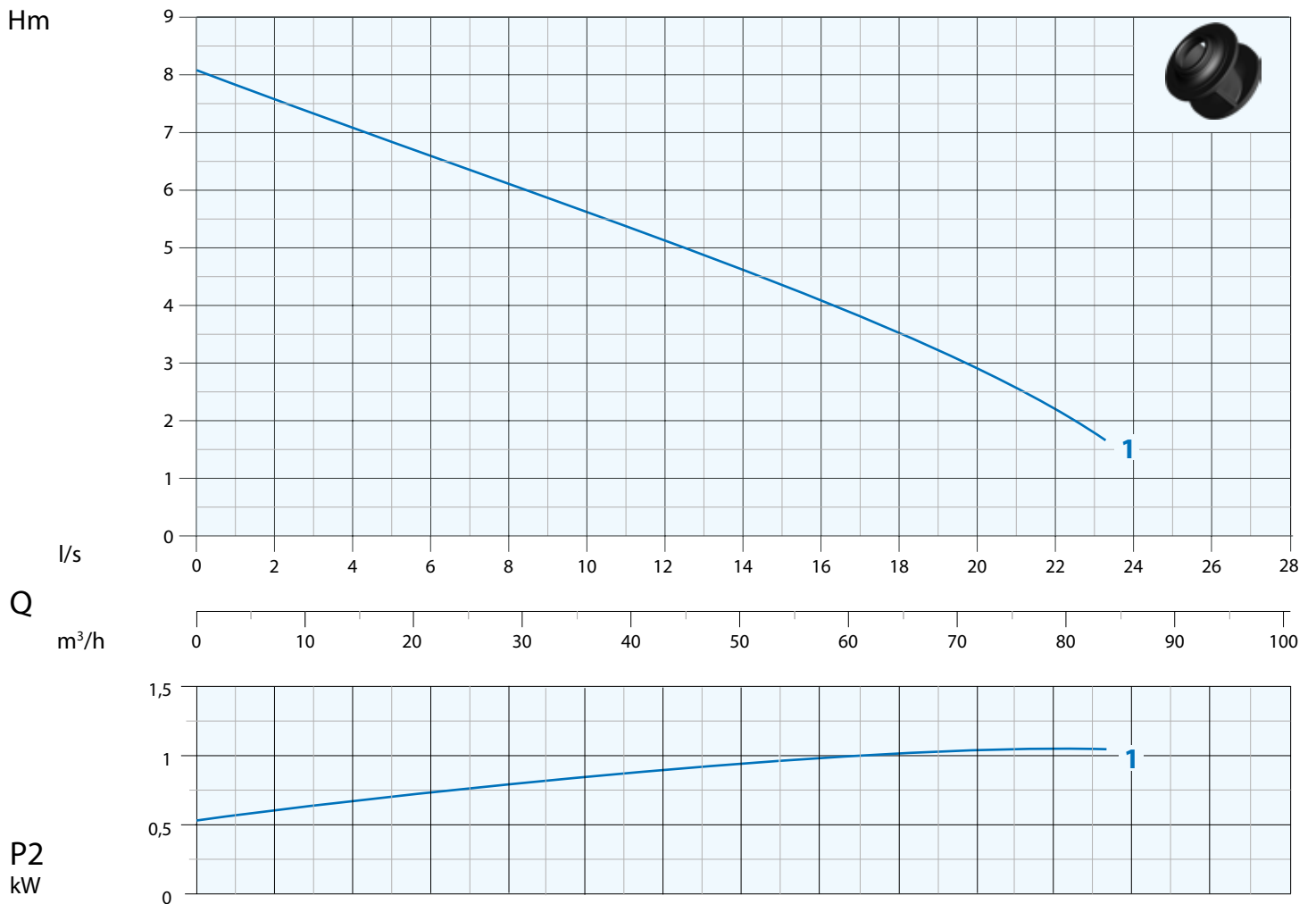

N°	Type																
		1	2	4	6	8	10	12	14	16	18	20	22				
		l/s	l/m	m³/h	mt	7,8	7,5	7	6,5	6	5,5	5	4,5	4	3,5	2,8	2,5
1	DNB 80-4/110 M/T																

N°	Type	EX	Delivery	Free Passage	kW		HP	R.P.M. 1/min	A		Hz	
					P1	P2			1 Phase - 230V	µf		3 Phase - 400V
1	DNB 80-4/110 M/T	•	DN80 PN16	70 mm	1,5	1,1	1,5	1450	7,6	35	3,2	50

• Available explosion proof pump



EPT 17 ATEX 2701 X



Ex db IIB T4 Gb  
Ex h IIB T4 Gb  
0°C Ta 40°

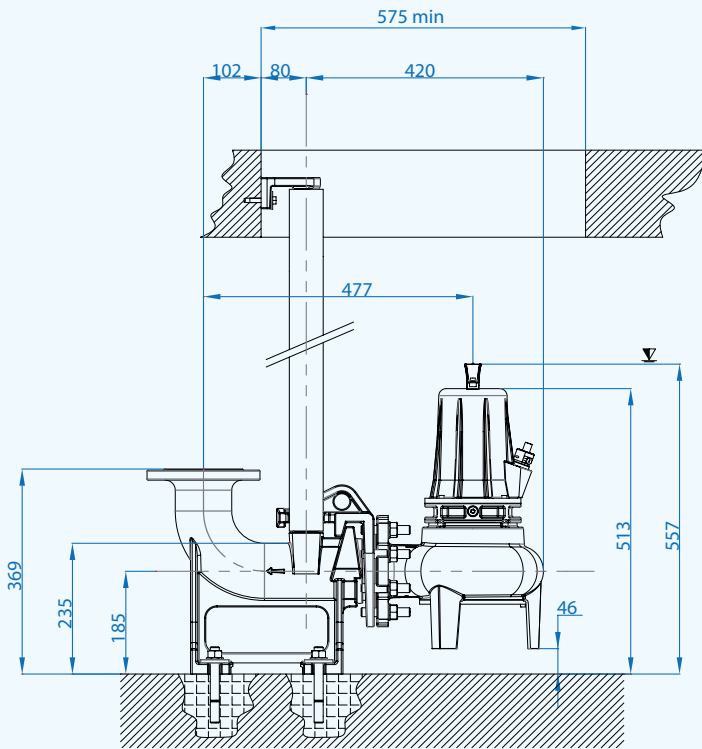

\* VERSIONI ATEX - ATEX VERSION

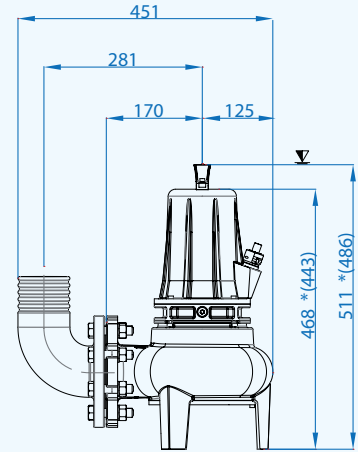

▽ Minimum submersion

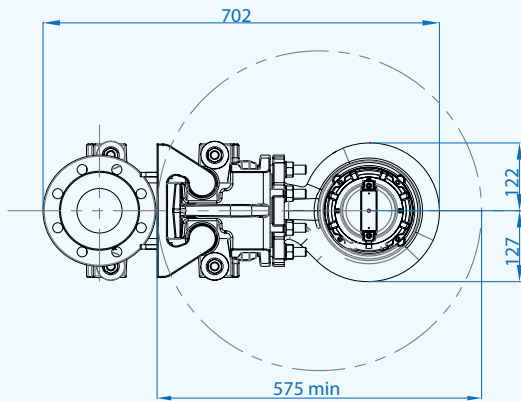

DN80 PN16  
ex UNI 2278

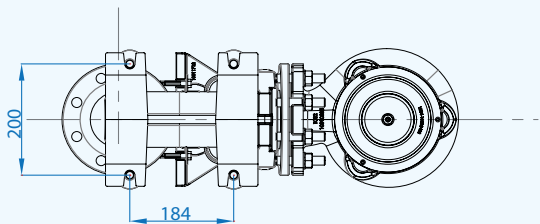
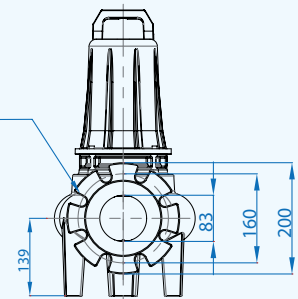

## Cables

	Phases	Cable	Cable cross section mm <sup>2</sup>	mt
Standard	1 ~ 230V	H07RN8F	4x1,5+2x0,50 Ø12*	10
	3 ~ 400V		4x1,5+2x0,50 Ø12**	10
Versioni/Versions ATEX	1 ~ 230V	NSSHÖU-J	4x1,5+2x0,50 Ø12*	10
	3 ~ 400V		4x1,5+2x0,50 Ø12**	10

\* Standard with Control Box

\*\* Free terminals

## Packaging dimensions

Tipo - Type	X mm	Y mm	Z mm	Kg
DNB 80-4/110 M/T	260	585	315	36



## Optional



Explosion proof control box available on request



For single phase pumps:  
Control-box with external  
main capacitor



Automatic coupling foot  
Type: DUTY 80 and B5

Flanged hose connection N2

## Submersible electropumps with open channel impeller

Power:	<b>1.5÷9 kW</b>
Delivery:	<b>DN65-80</b>



### Application

The A 2 poles Series is used in pumping and draining clear liquids and sewage. High performance renders it useful in a variety of applications: water treatment plants, industrial plants, farms and sewers.

### Characteristic

All main components are made of grey cast iron GG25. Two individual mechanical seals (motor side in the oil chamber, impeller side in contact with the liquid) and high quality parts, ensure the perfect functioning and reliability of the product.

### Motor range

- Squirrel cage motor at 2 poles
- Thermal protection T1 and T2 embedded in the motor winding (to be wired to the three pole contactor in the control panel)
- Class F insulation (155°C)
- IP 68 protection

### Motor cooling

The cooling of the motor is ensured by the liquid where the pump is submerged.

### Limits of use

- Max. permissible liquid temperature: 40°C with pump fully submerged
- On request, special version (excluded ATEX) to withstand liquid temperature up to 60°C with pump fully submerged, no S1 service
- Maximum depth of immersion: 20 MT.
- Permissible pH value: 6-10
- Hydraulic features suitable for liquids with density <math>< 1,1 \text{ kg/dm}^3</math>
- Allowed voltage: 230/400V or 400/690V±5% depending on the pump
- Allowed frequency: 50Hz ±2%

### Designation

**AT-EX 80 / 2 / 173 C.254**

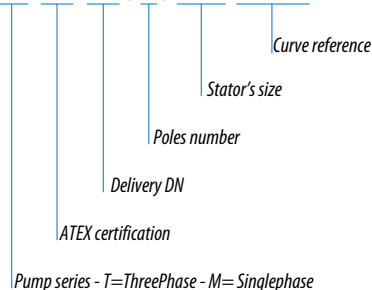

### Performance Overview

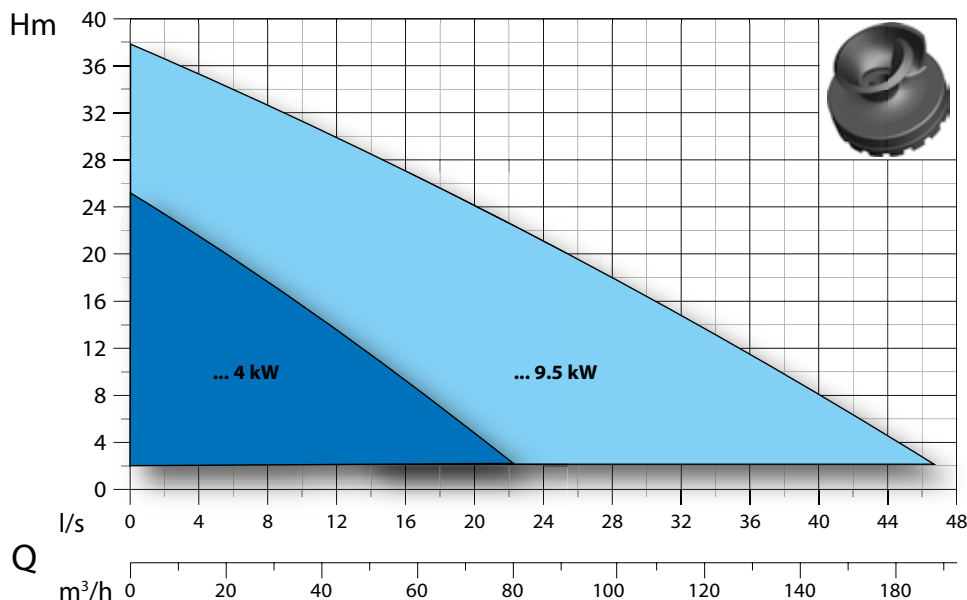

### Curves Identification

- DN65
- DN80

### Norms

According to ISO 9906:2012 3B2

### List of components and materials

Chain ring

Stainless steel AISI 416

Motor casing

Cast iron GG25

Upper bearing

Motor shaft Stainless

steel AISI 420

Electric motor

Rotor

Lower bearing

Flange support

Cast Iron GG25

Mechanical seal

Carbon/Ceramic (CA/CE/Viton)

Motor holder

Cast Iron GG25

Mechanical seal

Silicon/Carbide

Body pump

Cast iron GG25

Impeller

Cast iron GG25

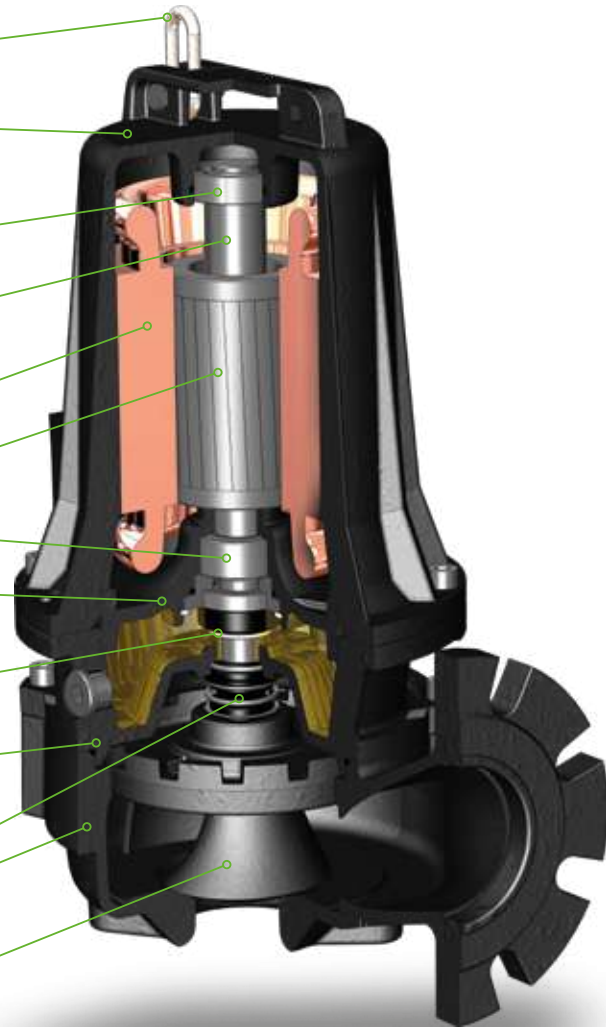

### Technology and Features

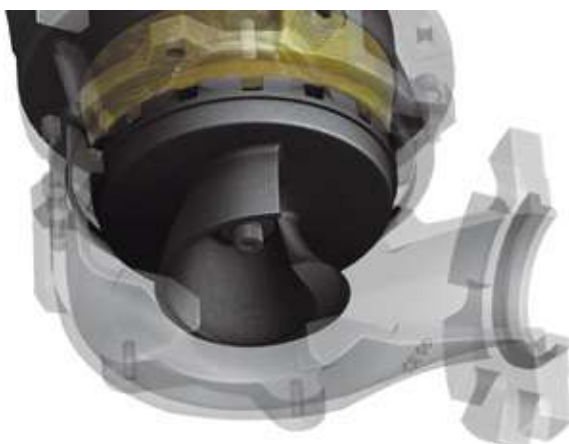

#### Impellers

The A series is fitted with open single channel and highly efficient impellers. The shredding system ensures a high degree of reliability even in presence of fibrous materials and solids in suspension.



Explosion proof pumps



II 2G Ex db IIB T4 Gb  
Ex h IIB T4 Gb  
0° ~ Ta ~ 40°

EPT 17 ATEX 2702 X

Pumps with explosion proof available on request.



#### Seal leak detector

The seal leak detector is certified according to the norm ATEX EN 60079-0, EN 60079-1 (through safety barrier) and fitted standard on all series.



#### Cable gland

The cable gland is made of stainless steel AISI 316 and certified according to the norm ATEX EN 60079-0, EN 60079-1. Standard on all series.

### Horizontal Outlet DN65 PN10 - RPM 2850 1/min 2 poles

Picture for illustration purposes only



### Performance Curve

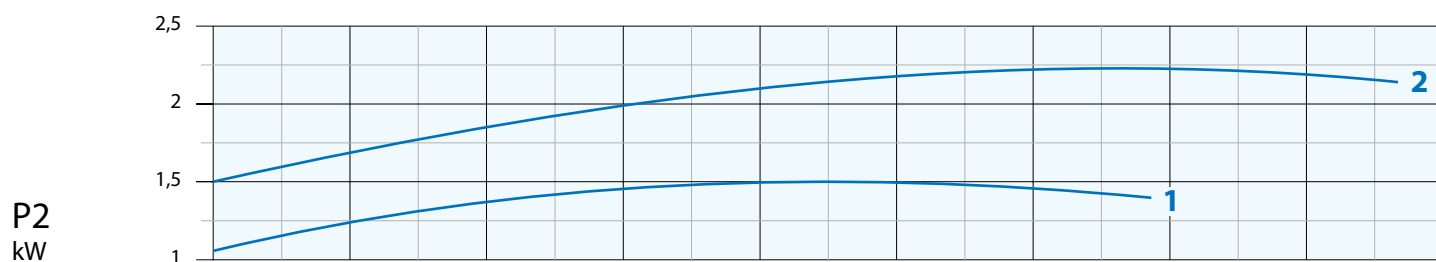
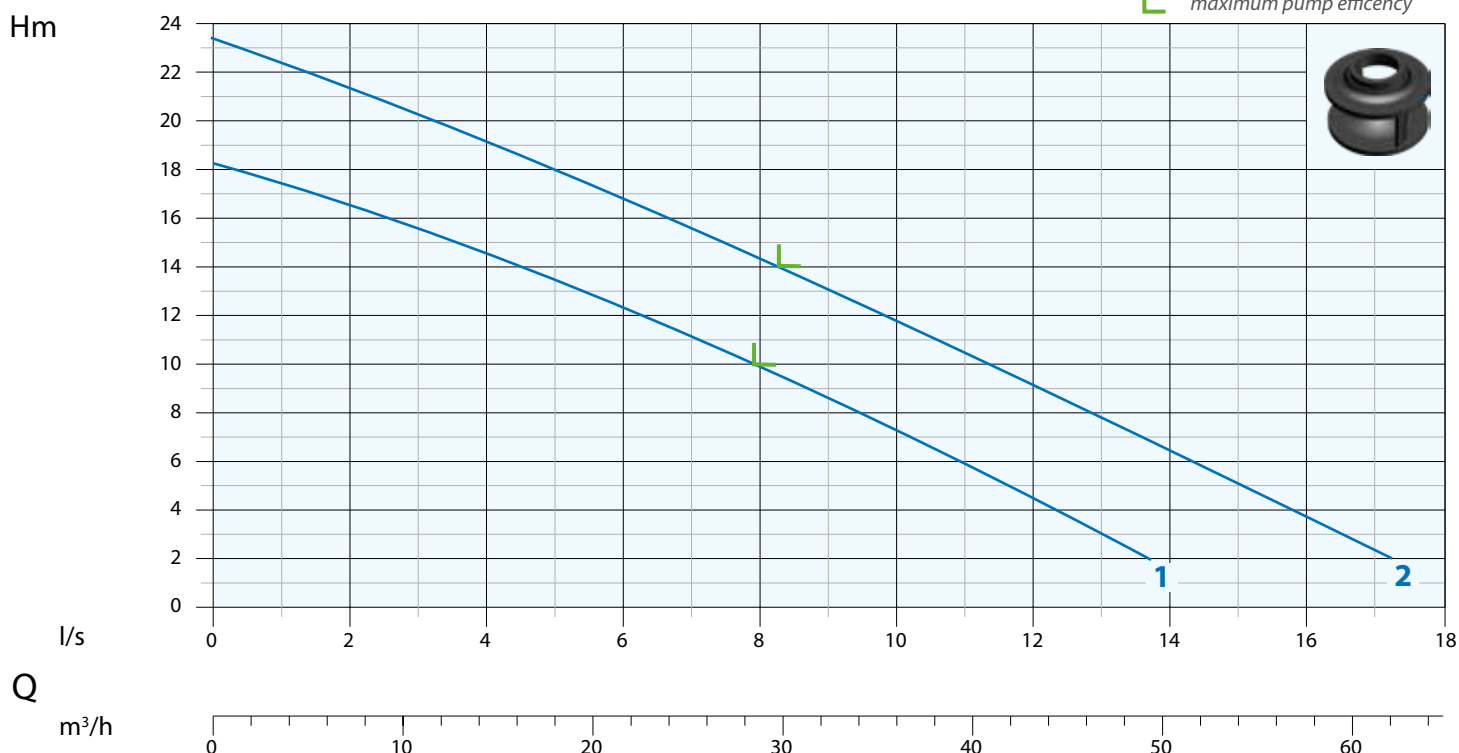

N°	Type	l/s	1	2	4	6	8	10	12	14	16
			l/m	60	120	240	360	480	600	720	840
		m <sup>3</sup> /h	3,6	7,2	14,4	21,6	28,8	36,0	43,2	50,4	57,6
1	AM-AT 65/2/125 C.236	mt	17,5	16,5	14,5	12,5	10	7	4,5	2	
2	AT 65/2/125 C.237		22,5	21,5	19	17	14,5	11,5	9	6,5	3,5

N°	Type	EX	Delivery	Free Passage	kW		HP	R.P.M. 1/min	A			Hz
					P1	P2			1 Phase - 230V	µf	3 Phase - 400V	
1	AM-AT 65/2/125 C.236	•	DN65 PN10	40 mm	2,3	1,5	2	2850	11	35	3,8	50
2	AT 65/2/125 C.237	•			3,1	2,2	3					

• Available explosion proof pump with certifications:



Ex db IIB T4 Gb  
Ex h IIB T4 Gb  
0° Ta 40°

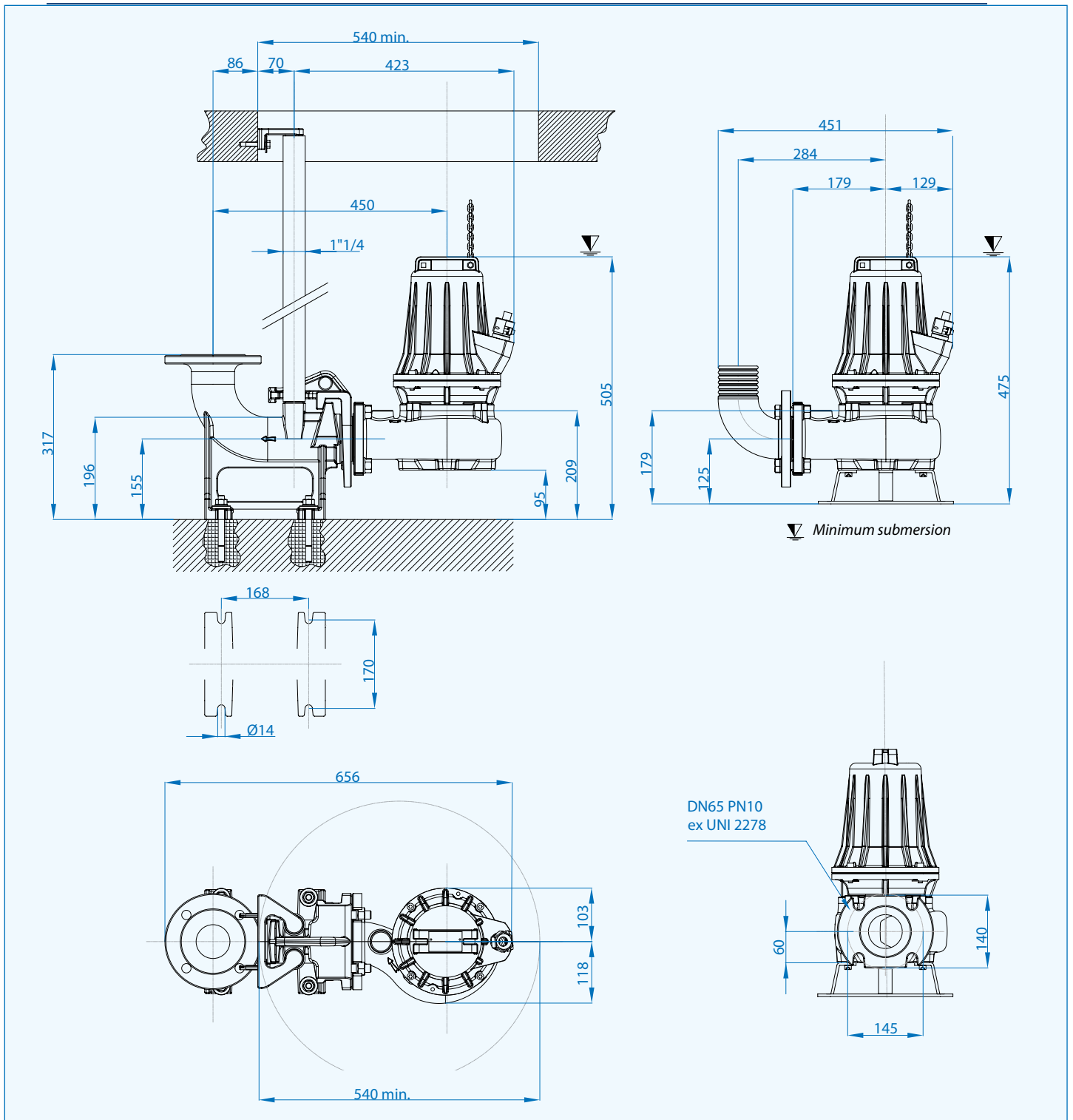

### Cables

Version	Phases	Cable	Cable cross section mm <sup>2</sup>	mt
Standard	1 ~ 230V	H07RN8F	4x1,5+3x0,50 Ø15*	10
ATEX		NSSHÖU-J	4x1,5+3x0,50 Ø17*	10
Standard	3 ~ 400V	H07RN8F	4x1,5+3x0,50 Ø15**	10
ATEX	D.O.L.	NSSHÖU-J	4x1,5+3x0,50 Ø17**	10

\* Standard with Control-box (starting capacitor included)

\*\* Free terminals

### Packaging dimension

Type	X mm	Y mm	Z mm	Kg
AM-AT 65/2/125 C.236				43
AT 65/2/125 C.237	295	460	331	43,5

### Optional



Automatic coupling foot  
Type: DUTY 65 or B4(PN10)



Flanged hose connection N5  
Foot support P4 DN65



Stainless steel handle



Explosion proof control box available on request



Horizontal Outlet DN65 PN10 -  
RPM 2850 1/min 2 poles

Picture for illustration purposes only



### Performance Curve

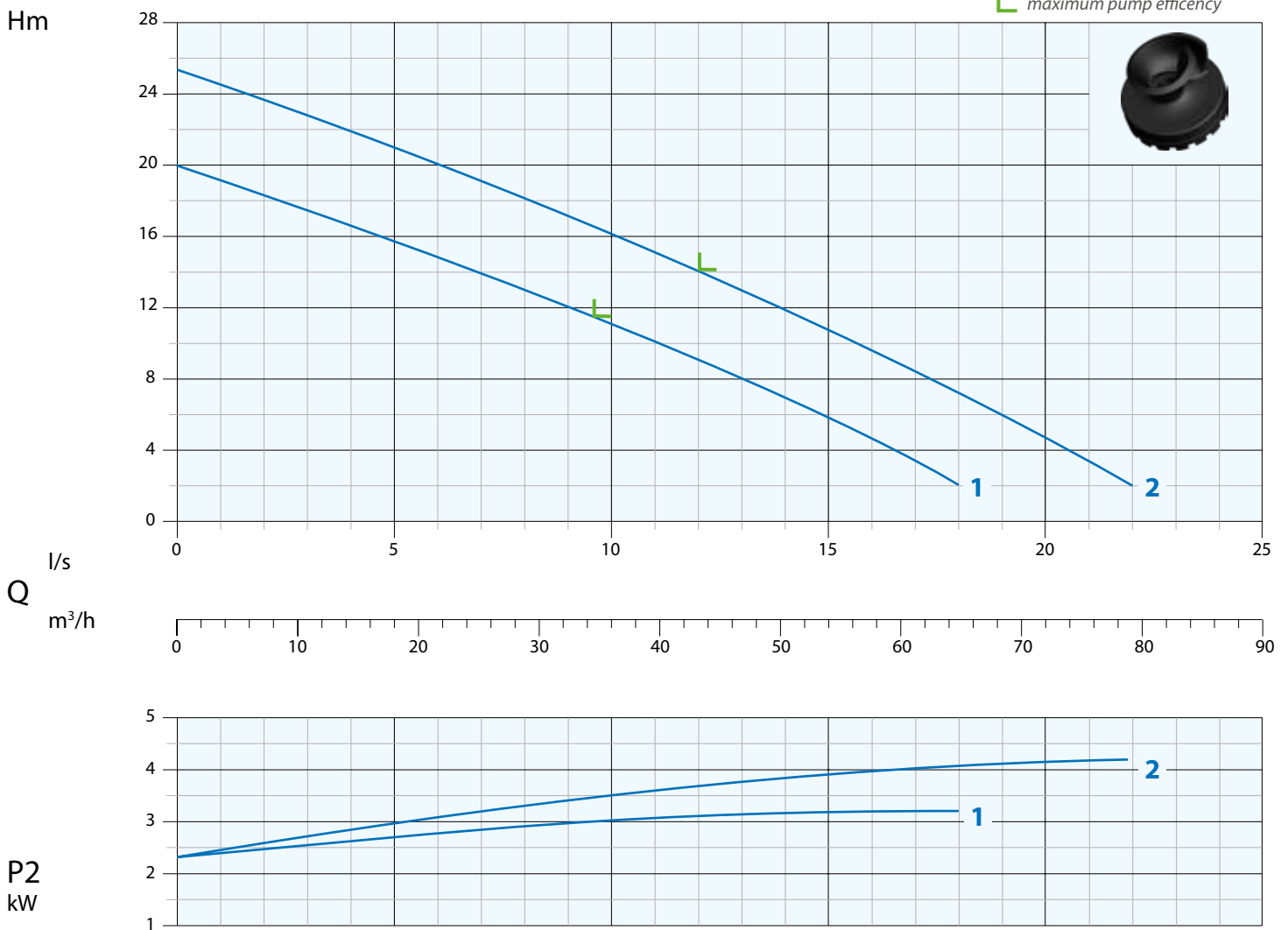

N°	Type	l/s	2	4	6	8	10	12	14	16	18	22
			l/m	120	240	360	480	600	720	840	960	1080
		m³/h	7,2	14,4	21,6	28,8	36	43,2	50,4	57,6	64,8	79,2
1	AT 65/2/152 C. 246	mt	18	17	15	13	11	9	7	5	2	
2	AT 65/2/152 C. 247	mt	23,5	22	20	18	16	14	12	9,5	7,5	2

N°	Type	EX	Delivery	Free Passage	kW		HP	R.P.M. 1/min	A	
					P1	P2			3 Phase - 400V	
1	AT 65/2/152 C. 246	•	DN65 PN10	45 mm	4,1	3,2	4	2850	6,9	50
2	AT 65/2/152 C. 247	•			5,6	4,2	5,5		9,4	50

• Available explosion proof pump with certifications:



Ex db IIB T4 Gb  
Ex h IIB T4 Gb  
0° - Ta - 40°

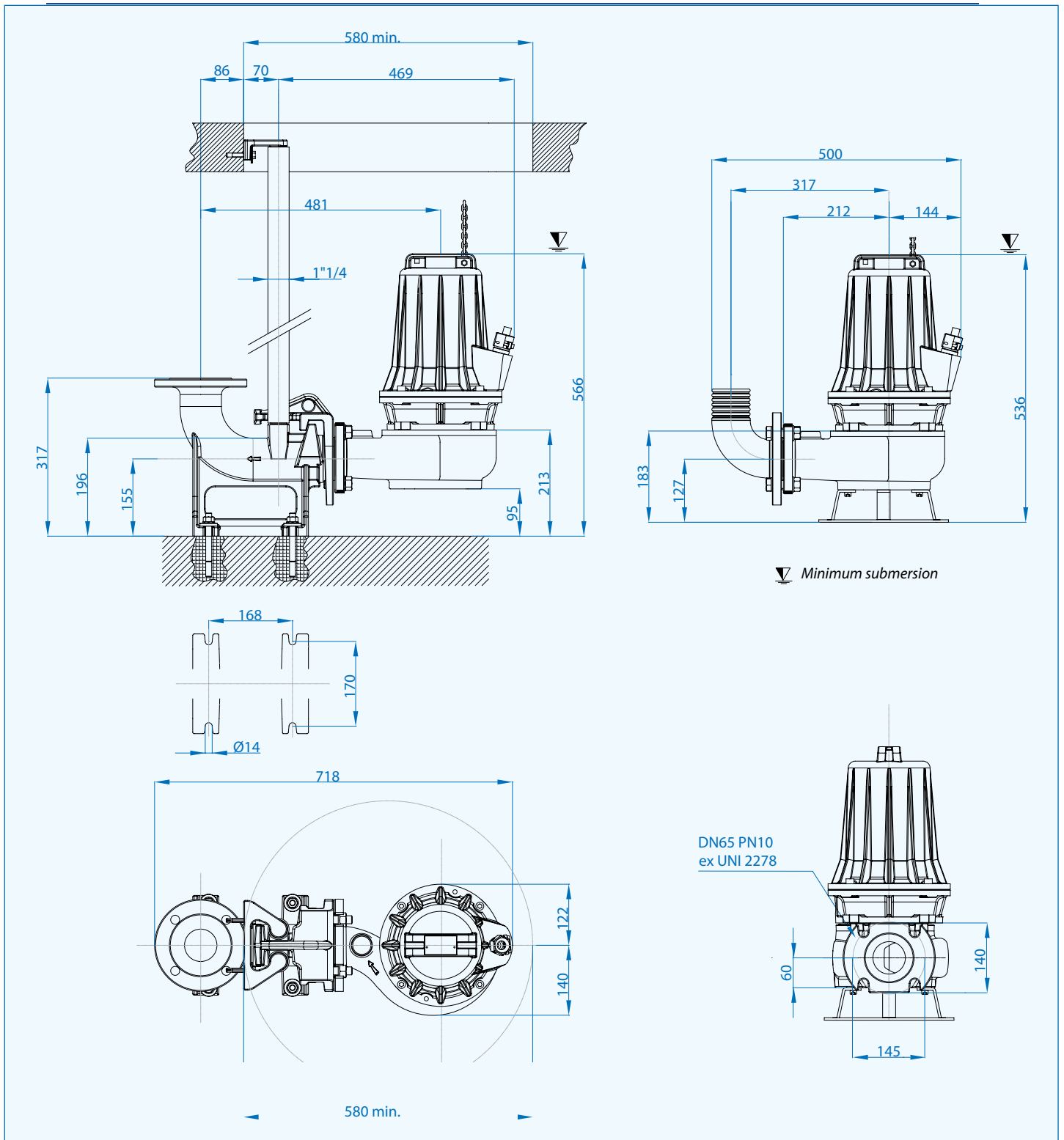

Minimum submersion

### Cables

Version	Phases	Cable	Cable cross section mm <sup>2</sup>	mt
Standard	3 ~ 400V	H07RN8F	4x1,5+3x0,50 Ø15*	10
ATEX	D.O.L.	NSSHÖU-J	4x1,5+3x0,50 Ø17*	10

\* Free terminals

### Packaging dimension

Type	X mm	Y mm	Z mm	Kg
AT 65/2/152 C. 246				60
AT 65/2/152 C. 247	355	580	420	62,5



### Optional



Automatic coupling foot  
Type: DUTY 65 / B4 (PN10)



Flanged hose connection N5  
Foot support P4 DN65



Stainless steel handle

## Horizontal Outlet DN80 PN16 - RPM 2850 1/min 2 poles

Picture for illustration purposes only



### Performance Curve

L = maximum pump efficiency

L = minimum head for ATEX operation

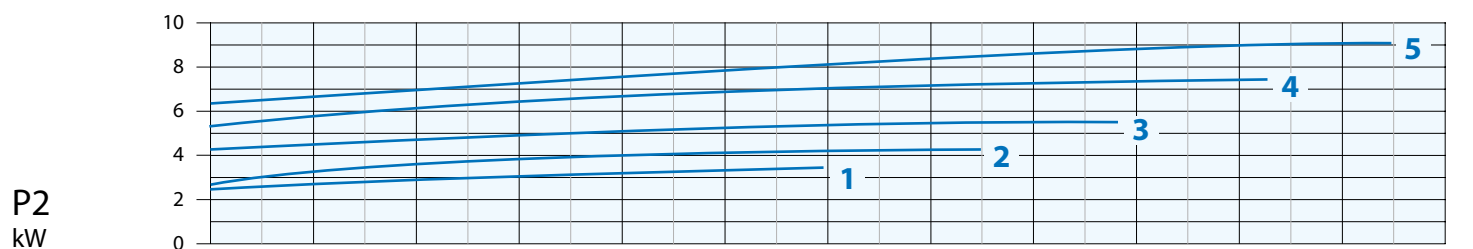
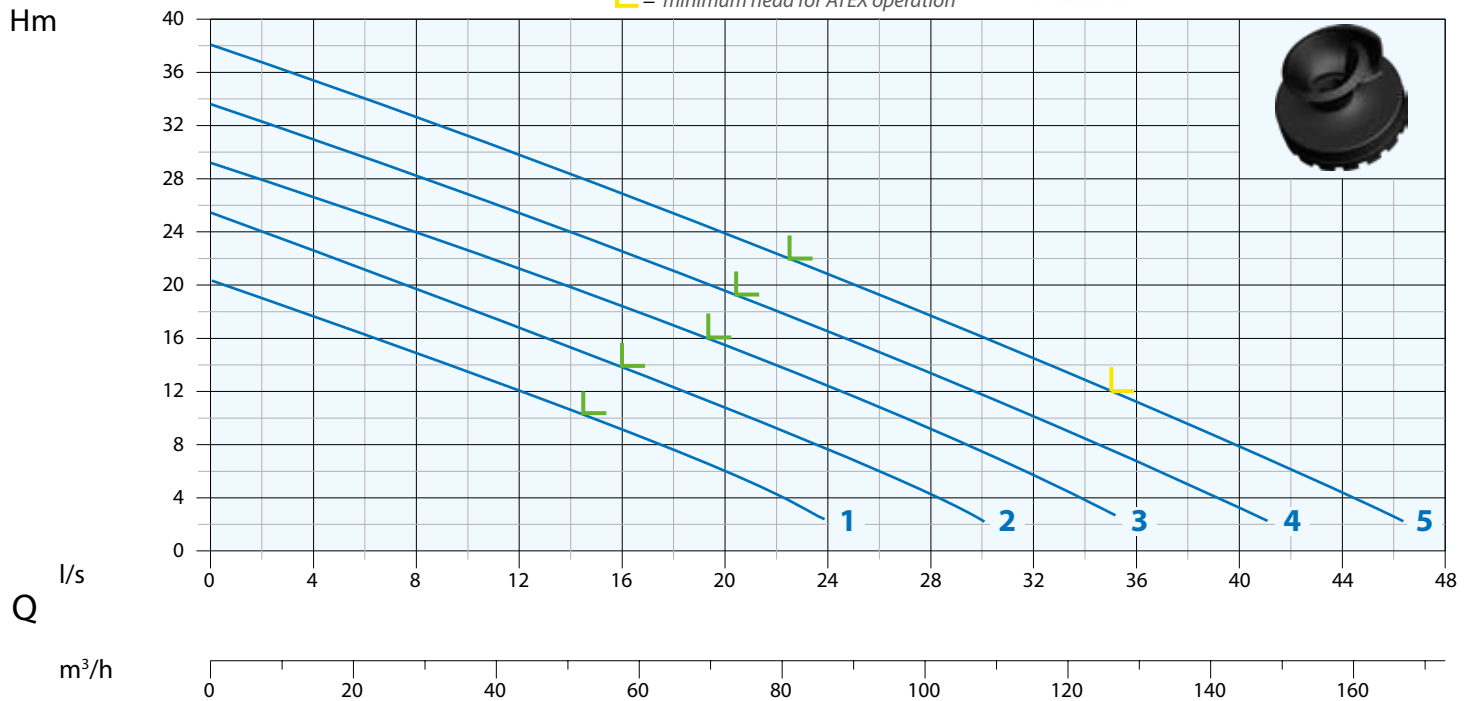

N°	Type	I/s	4	8	12	16	20	24	28	32	36	44
		l/m	240	480	720	960	1200	1440	1680	1920	2160	2640
		m³/h	14,4	28,8	43,2	57,6	72	86,4	100,8	115,2	129,6	158,4
1	AT 80/2/152 C.246	mt	18	15	12	9	6	2				
2	AT 80/2/152 C.247		22	20	17	14	11	8	4			
3	AT 80/2/173 C.254		26	24	21	18	15,5	12	9	6		
4	AT 80/2/173 C.257		31	28	25	22,5	19,5	17	13	10	7	
5	AT 80/2/173 C.259		35	33	30	27	24	21	17,5	14,5	11	4

N°	Type	EX	Delivery	Free Passage	kW		HP	R.P.M. 1/min	A 3 Phase - 400V	Hz
					P1	P2				
1	AT 80/2/152 C.246	•	DN80 PN16	45 mm	4,0	3,2	4	2850	6,9	50
2	AT 80/2/152 C.247	•			5,6	4,2	5,5		9,4	
3	AT 80/2/173 C.254	•			7	5,5	7,5		11,5	
4	AT 80/2/173 C.257	•			8,7	7,5	10		14,5	
5	AT 80/2/173 C.259	•			11,1	9,1	12		18,6	

• Available explosion proof pump with certifications:



Ex db IIB T4 Gb  
Ex h IIB T4 Gb  
0° Ta - 40°

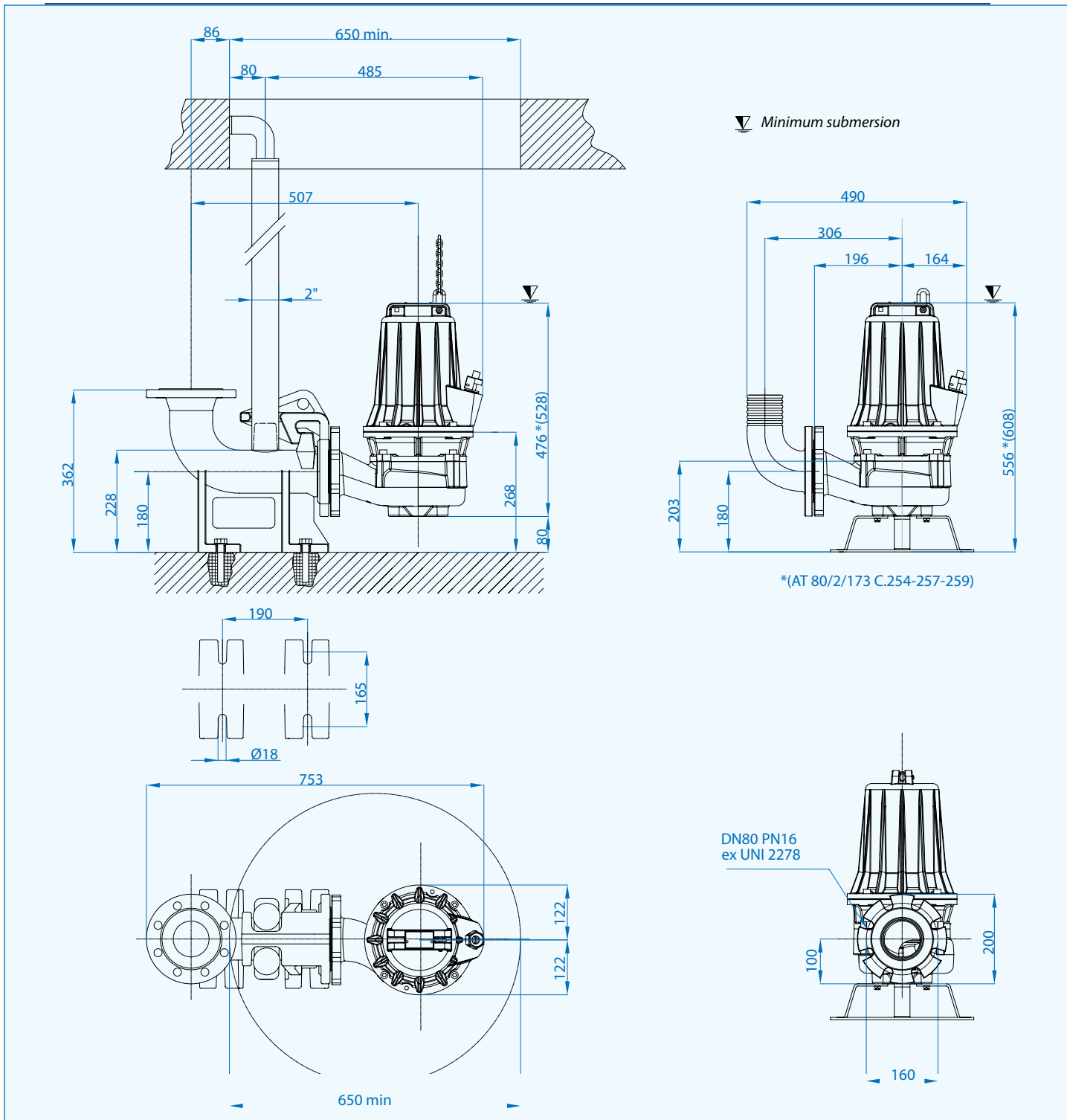

### Cables

Pumps	Version	Phases	Cable	Cable cross section mm <sup>2</sup>	mt
80/2/152	Standard	3 ~ 400V	H07RN8F	4x1,5+3x0,50 Ø17*	10
	ATEX	D.O.L.	NSSHÖU-J	4x1,5+3x0,50 Ø17*	10
80/2/173	Standard	3 ~ 400V	H07RN8F	7x1,5+3x0,50 Ø17*	10
	ATEX	Y-Δ	NSSHÖU-J	7x1,5+3x0,50 Ø17*	10

\* Free terminals

### Packaging dimension

Type	X mm	Y mm	Z mm	Kg
AT 80/2/152 C.246				61
AT 80/2/152 C.247				65
AT 80/2/173 C.254	355	580	420	92
AT 80/2/173 C.257				93
AT 80/2/173 C.259				94,5

### Optional



Automatic coupling foot  
Type: DUTY 80 and B5



Flanged hose connection N2  
80/2/152 Foot support P4  
80/2/173 Foot support P5



Stainless Steel  
Handle

## Submersible electropumps with open channel impeller

Power:	<b>1.5 ÷ 7.5 kW</b>
Delivery:	<b>DN80-100-150</b>



### Application

The A 4 poles Series is used to pump clear liquids and sewage. The wide range and high hydraulic efficiency renders this series particularly suited to water treatment plants, sewers, farming and industrial plants including in airports, underground public transport, hospitals and hotels.

### Characteristic

All main components are made of grey cast iron GG25. Two individual mechanical seals (motor side in the oil chamber, impeller side in contact with the liquid) and high quality parts, ensure the perfect functioning and reliability of the product.

### Motor range

- Squirrel cage motor 4 poles
- Thermal protection T1 and T2 embedded in the motor winding (to be wired to the three pole contactor in the control panel)
- Class F insulation (155°C)
- IP 68 protection

### Motor cooling

The cooling of the motor is ensured by the liquid where the pump is submerged.

### Limits of use

- Max. permissible liquid temperature: 40°C with pump fully submerged
- On request, special version (excluded ATEX) to withstand liquid temperature up to 60°C with pump fully submerged, no S1 service
- Maximum depth of immersion: 20 mt.
- Permissible pH value: 6-10
- Hydraulic features suitable for liquids with density <math>< 1,1 \text{ kg/dm}^3</math>
- Allowed voltage: 230/400V or 400/690V  $\pm 5\%$  depending on the pump
- Allowed frequency: 50Hz  $\pm 2\%$

### Designation

**AT-EX 80 / 4 / 173 C.256**

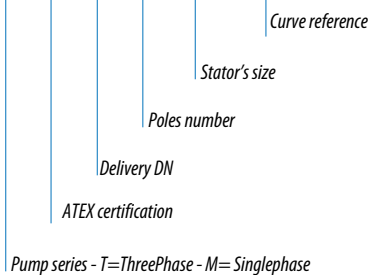

### Performance Overview

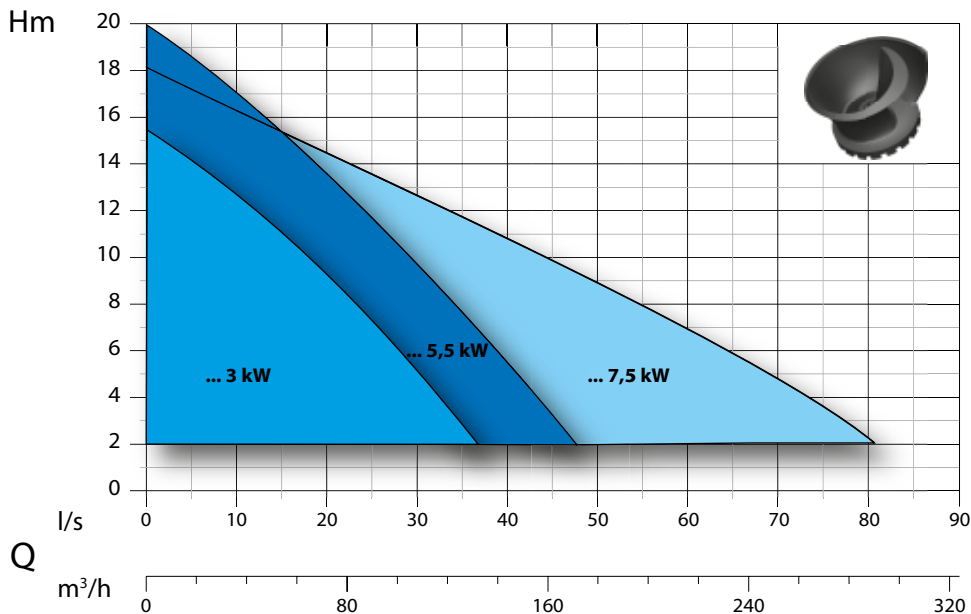

### Curves Identification

- DN80
- DN100
- DN150

### Norms

According to ISO 9906:2012 3B2

## List of components and materials

### Chain ring

Stainless steel AISI 416

### Motor casing

Cast iron GG25

### Upper bearing

### Motor shaft

Stainless steel AISI 420

### Electric motor

### Rotor

### Lower bearing

### Motor holder

Cast iron GG25

### Mechanical seal

Carbon/Ceramic (CA/CE/Viton)

### Motor holder

Cast iron GG25

### Mechanical seal

Silicon/Carbide (SIC/SIC/Viton)

### Body pump

Cast iron GG25

### Impeller

Cast iron GG25

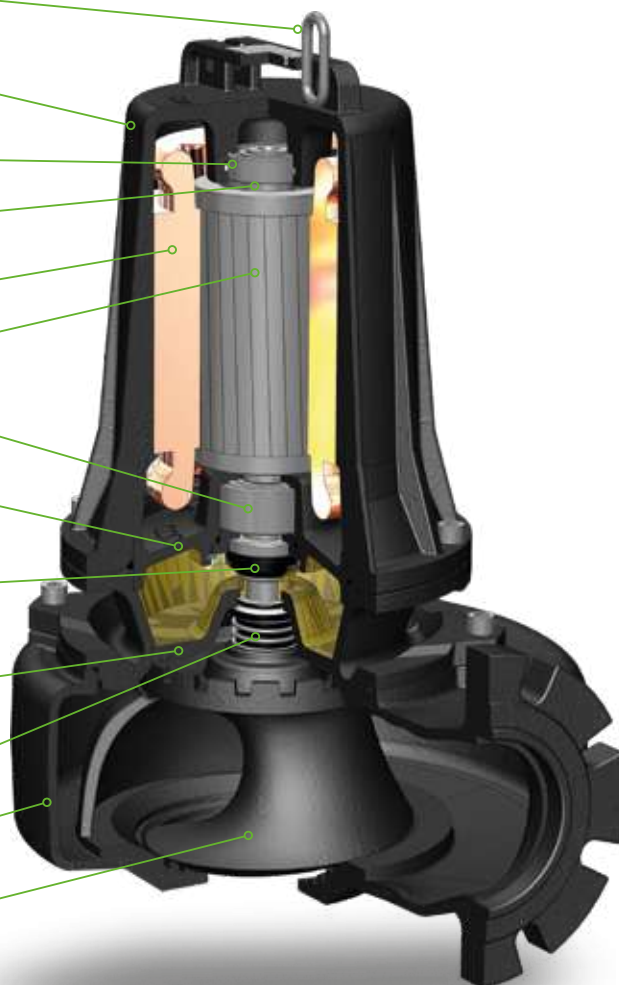

## Technology and Features

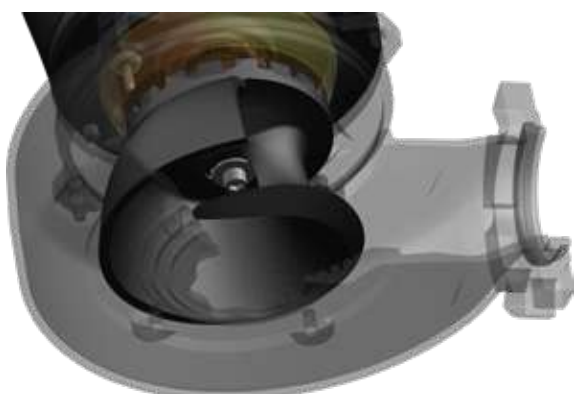

### Impellers

The A series is fitted with open single channel and highly efficient impellers. The shredding system ensure a high degree of reliability even in presence of fibrous materials and solids in suspension.



### Explosion proof pumps



II 2G

Ex db IIB T4 Gb  
Ex h IIB T4 Gb  
0° ~ Ta ~ 40°

EPT 17 ATEX 2702 X

Pumps with explosion proof available on request.



### Seal leak detector

The seal leak detector is certified according to the norm ATEX EN 60079-0, EN 60079-1 (through safety barrier) and fitted standard on all series.



### Cable gland

The cable gland is made of stainless steel AISI 316 and certified according to the norm ATEX EN 60079-0, EN 60079-1. Standard on all series.

### Horizontal Outlet DN80 PN16 - RPM 1450 1/min 4 poles

Picture for illustration purposes only



### Performance Curve

**L** maximum pump efficiency

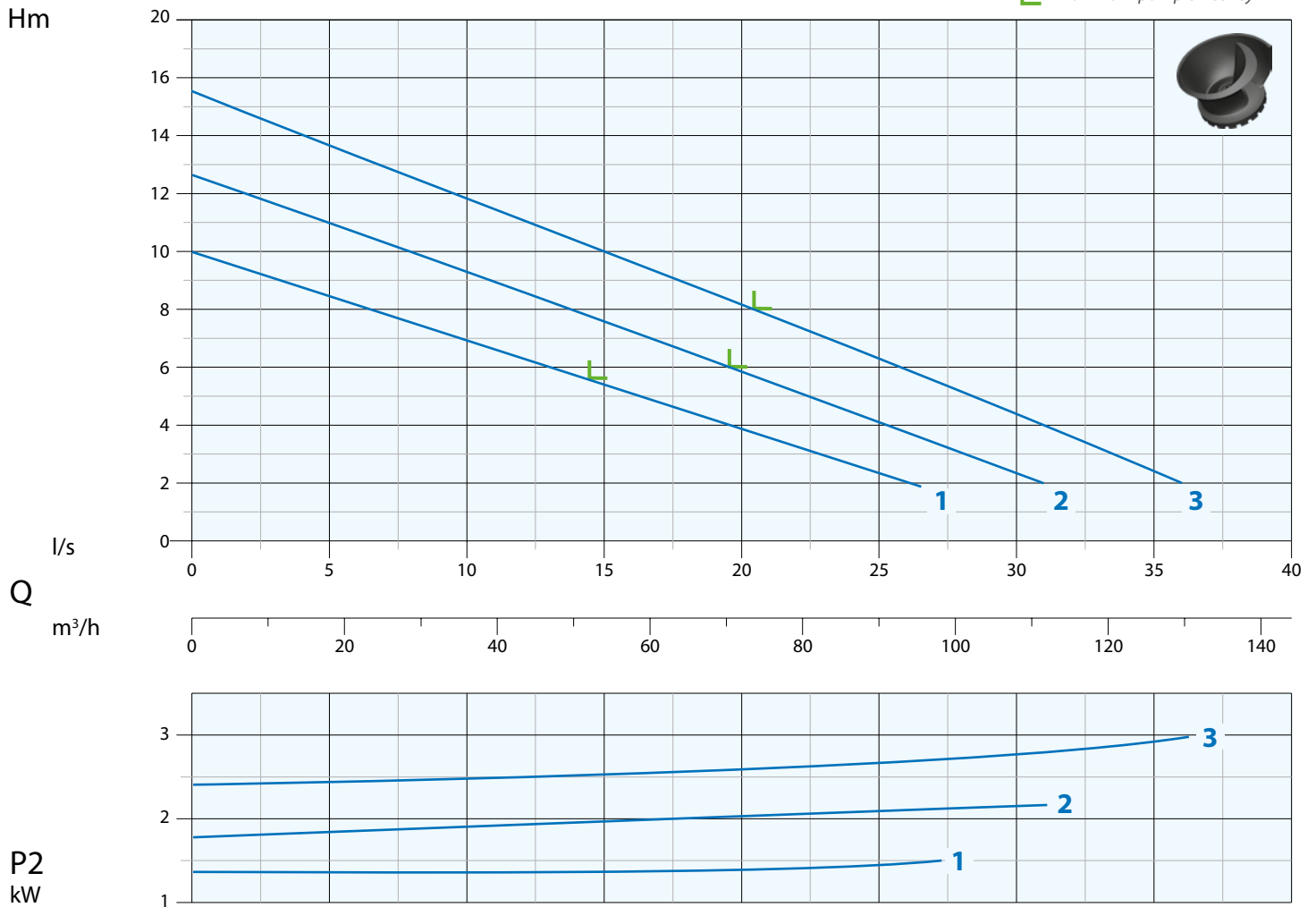

N°	Type	l/s	2,5	5	7,5	10	12,5	15	20	25	30	35
		l/m	150	300	450	600	750	900	1200	1500	1800	2100
		m³/h	9	18	27	36	45	54	72	90	108	126
1	AM-AT 80/4/125 C.242	mt	9	8,5	7,5	7	6	5,5	4	2,5		
2	AT 80/4/152 C.244		12	11	10	9,5	8,5	7,5	6	4	2,5	
3	AT 80/4/152 C.245		14,5	13,5	12,5	11,8	11	10	8	6,5	4,5	2,5

N°	Type	EX	Delivery	Free Passage	kW		HP	R.P.M. 1/min	A		Hz
					P1	P2			1 Phase - 230V	3 Phase - 400V	
1	AM-AT 80/4/125 C.242	•			2,2	1,5	2		10	45	3,8
2	AT 80/4/152 C.244	•	DN80 PN16	75 mm	2,9	2,2	3	1450			5,3
3	AT 80/4/152 C.245	•			3,9	3	4				7,2

• Available explosion proof pump with certifications:



EPT 17 ATEX 2702 X



Ex db IIB T4 Gb  
Ex h IIB T4 Gb  
0° ~ Ta ~ 40°

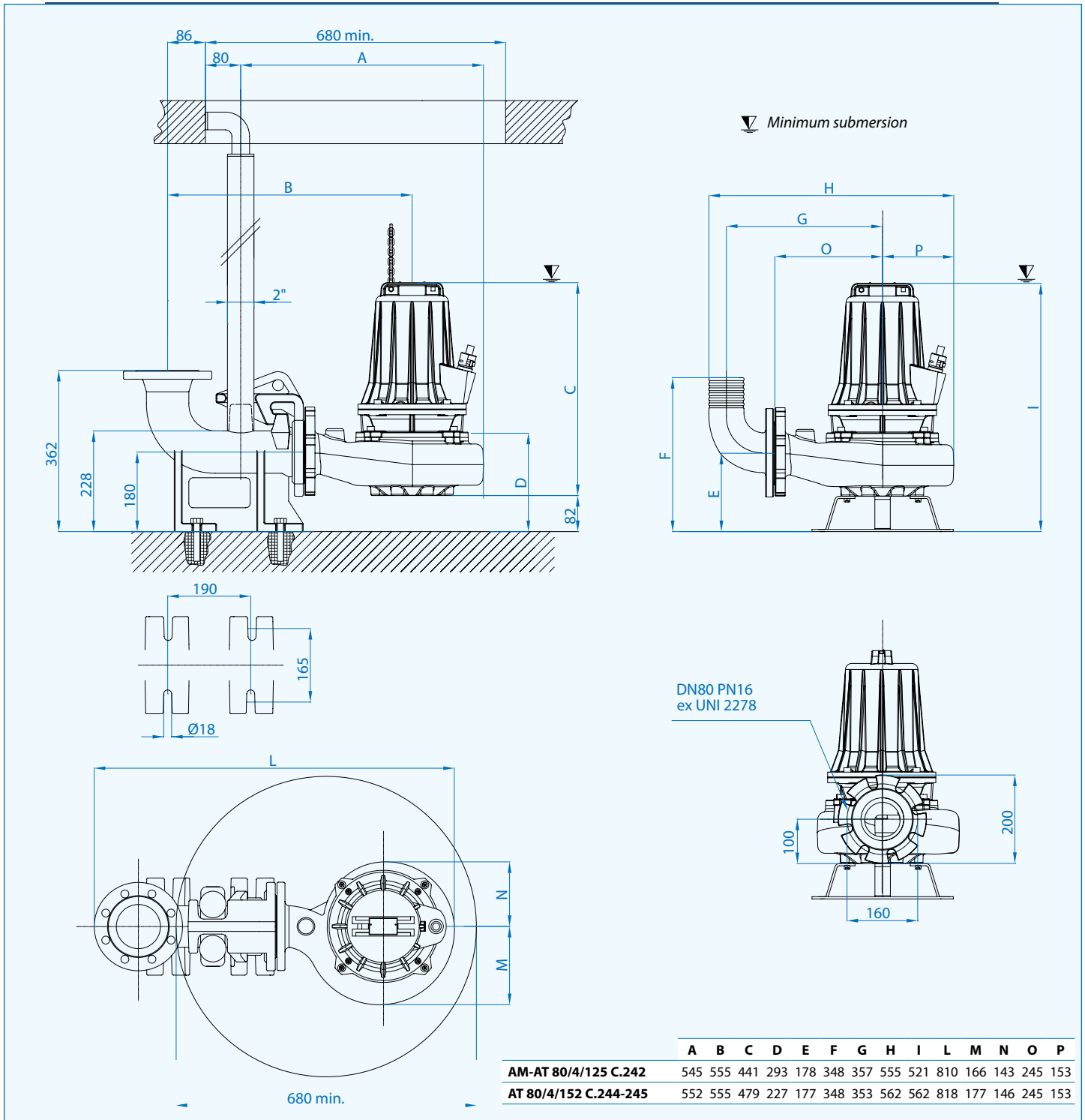

### Cables

Pumps	Version	Phases	Cable	Cable cross section mm <sup>2</sup>	mt
<b>80/4/125</b>	Standard	1 ~ 230V	H07RN8F	4x1,5+3x0,50 Ø15*	10
	ATEX		NSSHÖU-J	4x1,5+3x0,50 Ø17*	10
	Standard	3 ~ 400V	H07RN8F	4x1,5+3x0,50 Ø15**	10
			ATEX	D.O.L. NSSHÖU-J	4x1,5+3x0,50 Ø17**
<b>80/4/152</b>	Standard	3 ~ 400V	H07RN8F	4x1,5+3x0,50 Ø15**	10
	ATEX		D.O.L. NSSHÖU-J	4x1,5+3x0,50 Ø17**	10

\* Standard with Control-box (starting capacitor included)

\*\* Free terminals

### Packaging dimension

Type	X mm	Y mm	Z mm	Kg
<b>AM-AT 80/4/125 C.242</b>				56
<b>AT 80/4/152 C.244</b>	355	580	420	69
<b>AT 80/4/152 C.245</b>				72

### Optional





## Horizontal Outlet DN100 PN16 - RPM 1450 1/min 4 poles

Picture for illustration purposes only



### Performance Curve

L maximum pump efficiency

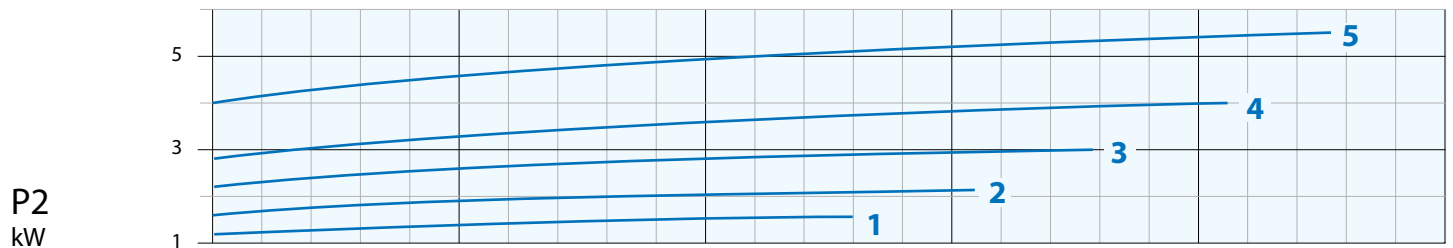
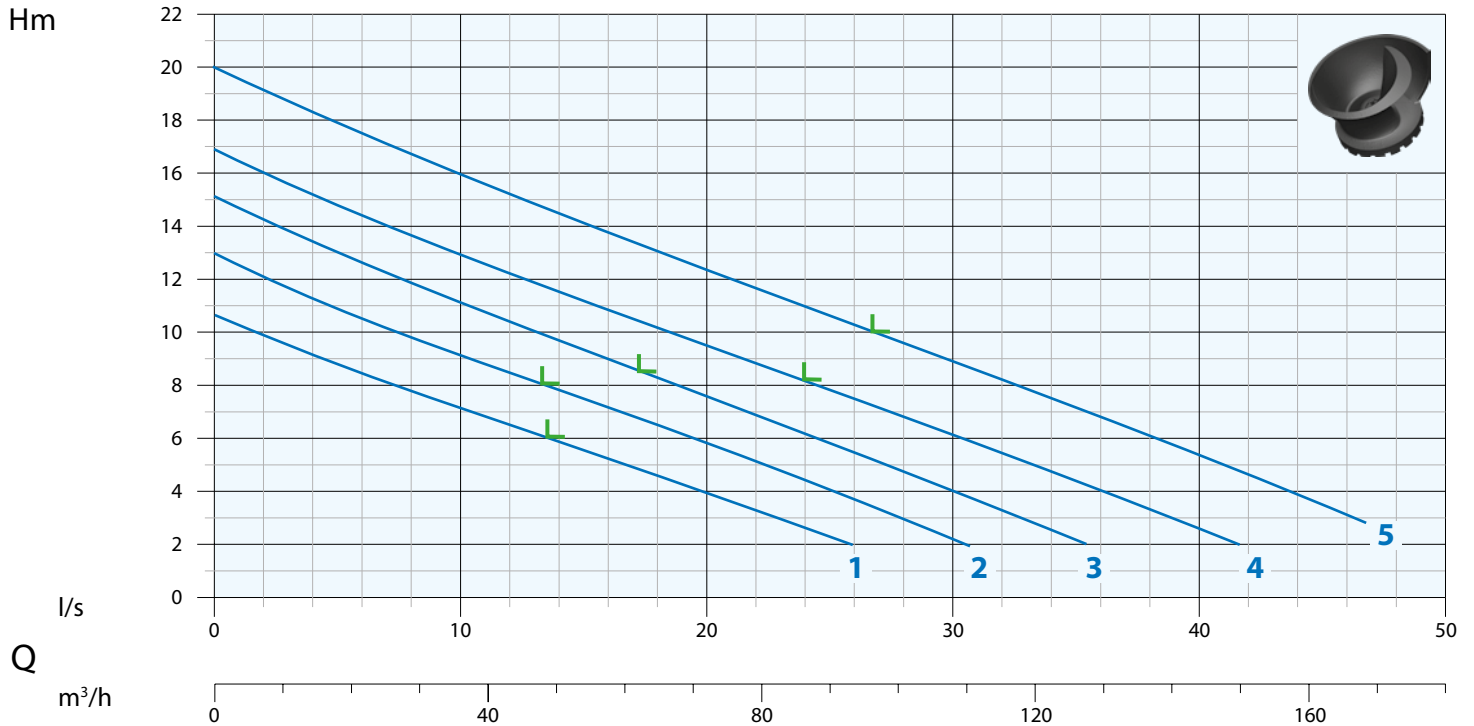

N°	Type	mt	I/s	2	6	10	16	20	26	30	36	40	46
			l/m	120	360	600	960	1200	1560	1800	2160	2400	2760
			m³/h	7,2	21,6	36	57,6	72	93,6	108	129,6	144	165,6
1	AT 100/4/152 C.243			10	8,5	7	5	4	2				
2	AT 100/4/152 C.244			12	10,5	9	7	6	3,5	2			
3	AT 100/4/152 C.245			14	12,5	11	9	7,5	5,5	4	2		
4	AT 100/4/173 C.255			16	14,5	13	11	9,5	7,5	6	4	2,5	
5	AT 100/4/173 C.256			19	17,5	16	13,5	12,5	10,5	9	7	5,5	3

N°	Type	EX	Delivery	Free Passage	kW			R.P.M. 1/min	A 3 Phase - 400V	Hz
					P1	P2	HP			
1	AT 100/4/152 C.243	•	DN100 PN16	75 mm	2,1	1,7	2,2	1450	3,9	50
2	AT 100/4/152 C.244	•			2,9	2,2	3		5,1	
3	AT 100/4/152 C.245	•			3,8	3	4		7	
4	AT 100/4/173 C.255	•			5,1	4	5,5		9,2	
5	AT 100/4/173 C.256	•			6,4	5,5	7,5		11,5	
					90 mm					

• Available explosion proof pump with certifications:



Ex db IIB T4 Gb  
Ex h IIB T4 Gb  
0° Ta 40°

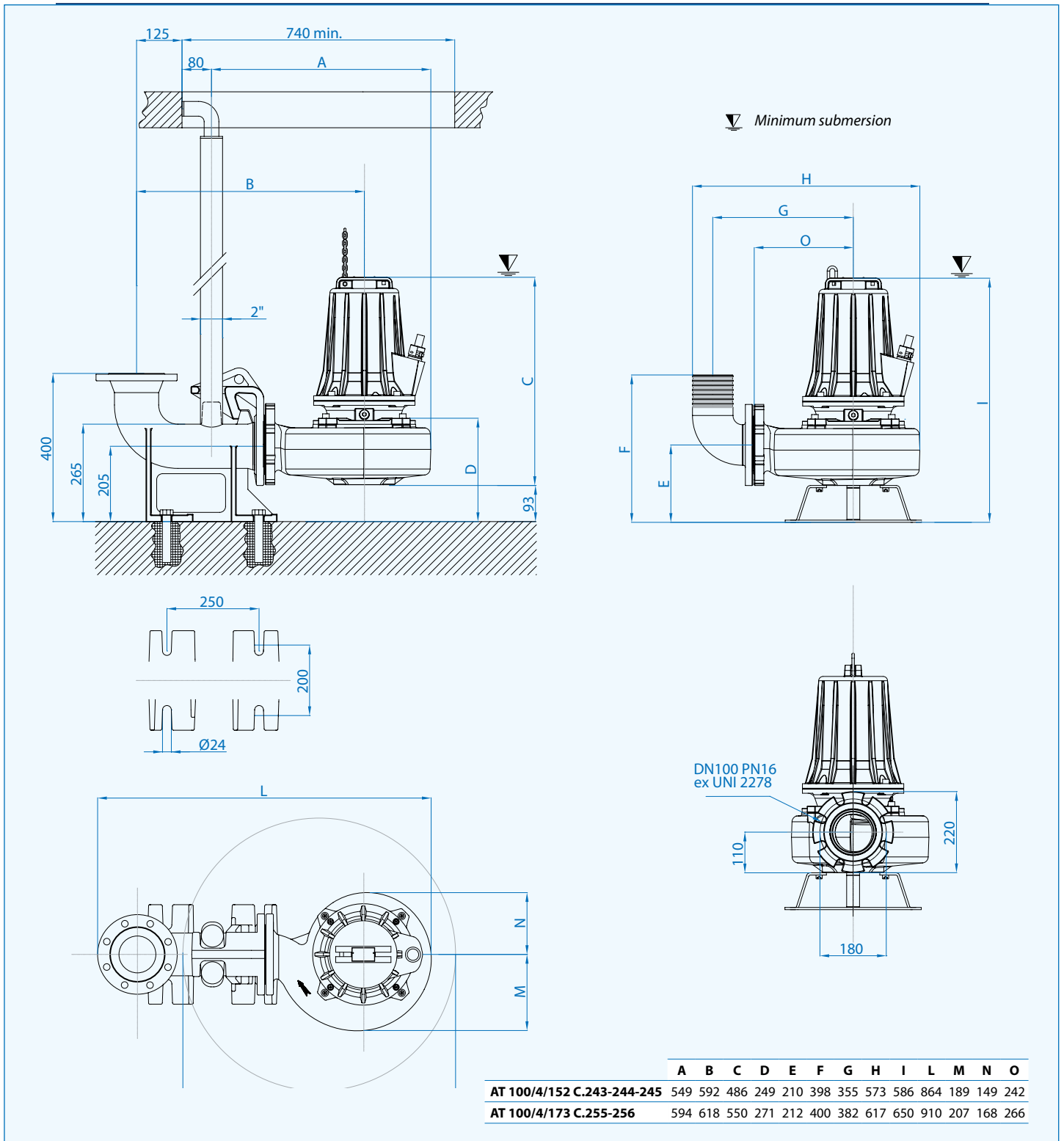

### Cables

Pumps	Version	Phases	Cable	Cable cross section mm <sup>2</sup>	mt
100/4/152	Standard	3 ~ 400V	H07RN8F	4x1,5+3x0,50 Ø15*	10
	ATEX	D.O.L.	NSSHÖU-J	4x1,5+3x0,50 Ø17*	10
100/4/173	Standard	3 ~ 400V	H07RN8F	7x1,5+3x0,50 Ø17*	10
	ATEX	Y-Δ	NSSHÖU-J	7x1,5+3x0,50 Ø17*	10

\* Free terminals

### Packaging Dimension

Type	X mm	Y mm	Z mm	Kg
AT 100/4/152 C.243	400	620	470	73
AT 100/4/152 C.244				73,5
AT 100/4/152 C.245				75,5
AT 100/4/173 C.255				103
AT 100/4/173 C.256				108

### Optional

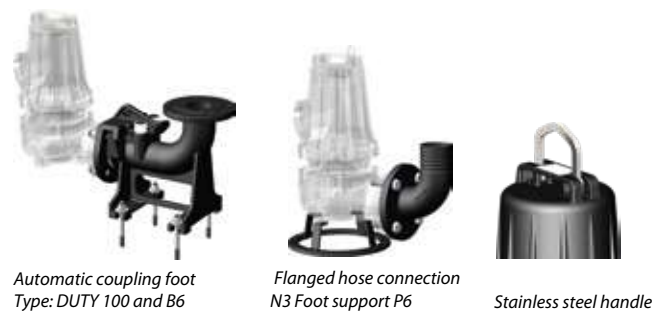

### Horizontal Outlet DN150 PN16 - RPM 1450 1/min 4 poles

Picture for illustration purposes only



#### Performance Curve

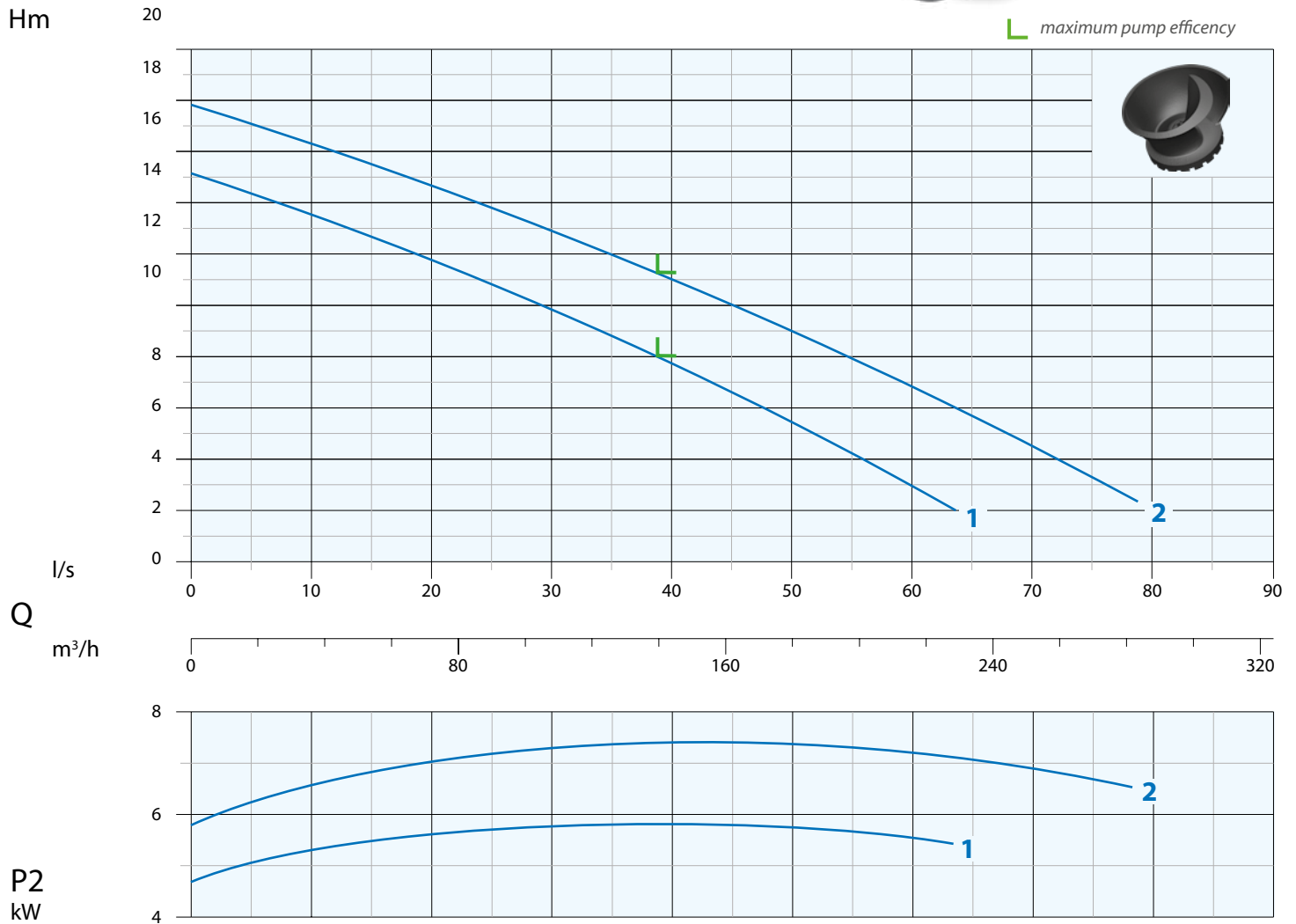

N°	Type	l/s	5	10	15	20	30	40	50	60	70	78
			l/m	300	600	900	1200	1800	2400	3000	3600	4200
		m³/h	18	36	54	72	108	144	180	216	252	280,8
1	AT 150/4/173 C.256	mt	14,5	13,5	12,5	12	10	7,5	5,5	3		
2	AT 150/4/173 C.258	mt	17	16,5	15,5	14,5	13	11	9	7	4,5	2,2

N°	Type	EX	Delivery	Free Passage	kW		HP	R.P.M. 1/min	A 3 Phase - 400V	Hz
					P1	P2				
2	AT 150/4/173 C.256		DN150 PN16	100 mm	6,8	5,8	7,9	1450	12,1	50
1	AT 150/4/173 C.258	•	DN150 PN16	100 mm	9,1	7,5	10	1450	15,6	50

• Available explosion proof pump with certifications:



EPT 17 ATEX 2702 X



Ex db IIB T4 Gb  
Ex h IIB T4 Gb  
0° - Ta - 40°

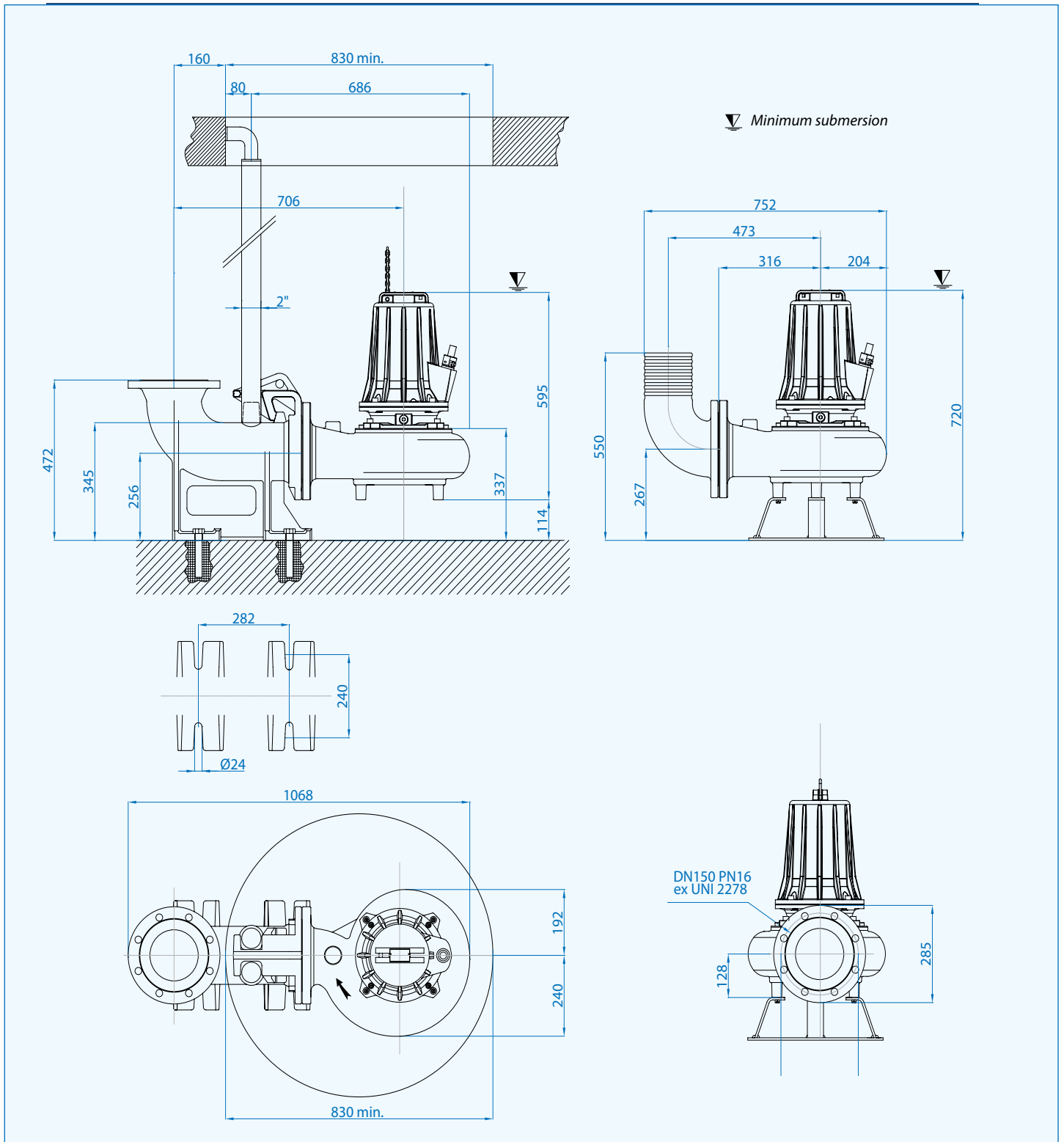

## Cables

Version	Phases	Cable	Cable cross section mm <sup>2</sup>	mt
Standard	3 ~ 400V	H07RN8F	7x1,5+3x0,50 Ø17*	10
ATEX	Y-Δ	NSSHÖU-J	7x1,5+3x0,50 Ø17*	10

\* Free terminals

## Packaging dimension

Type	X mm	Y mm	Z mm	Kg
AT 150/4/173 C.256	430	640	540	131
AT 150/4/173 C.258				132,5



## Optional



Automatic coupling foot  
Type: B7



Flanged hose connection N4  
Foot support P7



Stainless steel handle

## Submersible electropumps with close channel impeller

Power:	10÷60 kW
Delivery:	DN150 - 200



### Application

The A4 - A6 poles Series is used to pump clear liquids and sewage. The wide range and high hydraulic efficiency renders this series particularly suited to water treatment plants, sewers, farming and industrial plants including in airports, underground public transport, hospitals and hotels.

### Characteristic

All main components are made of grey cast iron GG25. Two individual mechanical seals (motor side in the oil chamber, impeller side in contact with the liquid) and high quality parts, ensure the perfect functioning and reliability of the product.

### Motor range

- Squirrel cage motor 4 -6 poles
- Thermal protection T1 and T2 embedded in the motor winding (to be wired to the three pole contactor in the control panel)
- Class F insulation (155°C)
- IP 68 protection

### Motor cooling

The cooling of the motor is ensured by the liquid where the pump is submerged.

### Limits of use

- Max. permissible liquid temperature: 40°C with pump fully submerged
- On request, special version (excluded ATEX) to withstand liquid temperature up to 60°C with pump fully submerged, no S1 service
- Maximum depth of immersion: 20 mt.
- Permissible pH value: 6-10
- Hydraulic features suitable for liquids with density <math>< 1,1 \text{ kg/dm}^3</math>
- Allowed voltage: 400V - 690V  $\pm 5\%$
- Allowed frequency: 50Hz  $\pm 2\%$

### Designation

**AT-EX 150 / 4 / 240 C.275**

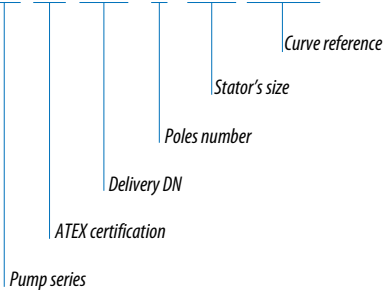

### Performance Overview

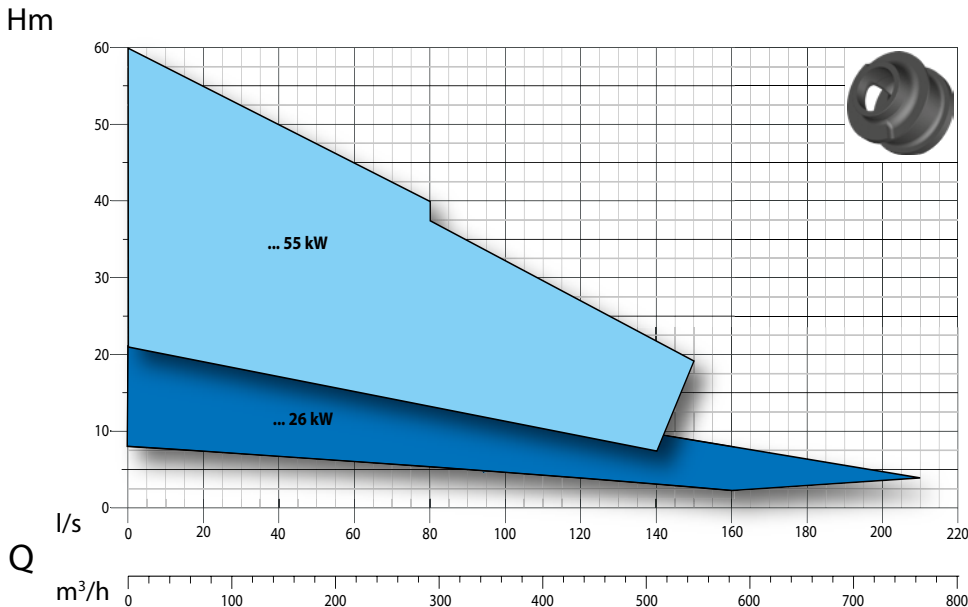

### Curves Identification

- DN150
- DN200

### Norms

According to ISO 9906:2012 3B2

### List of components and materials

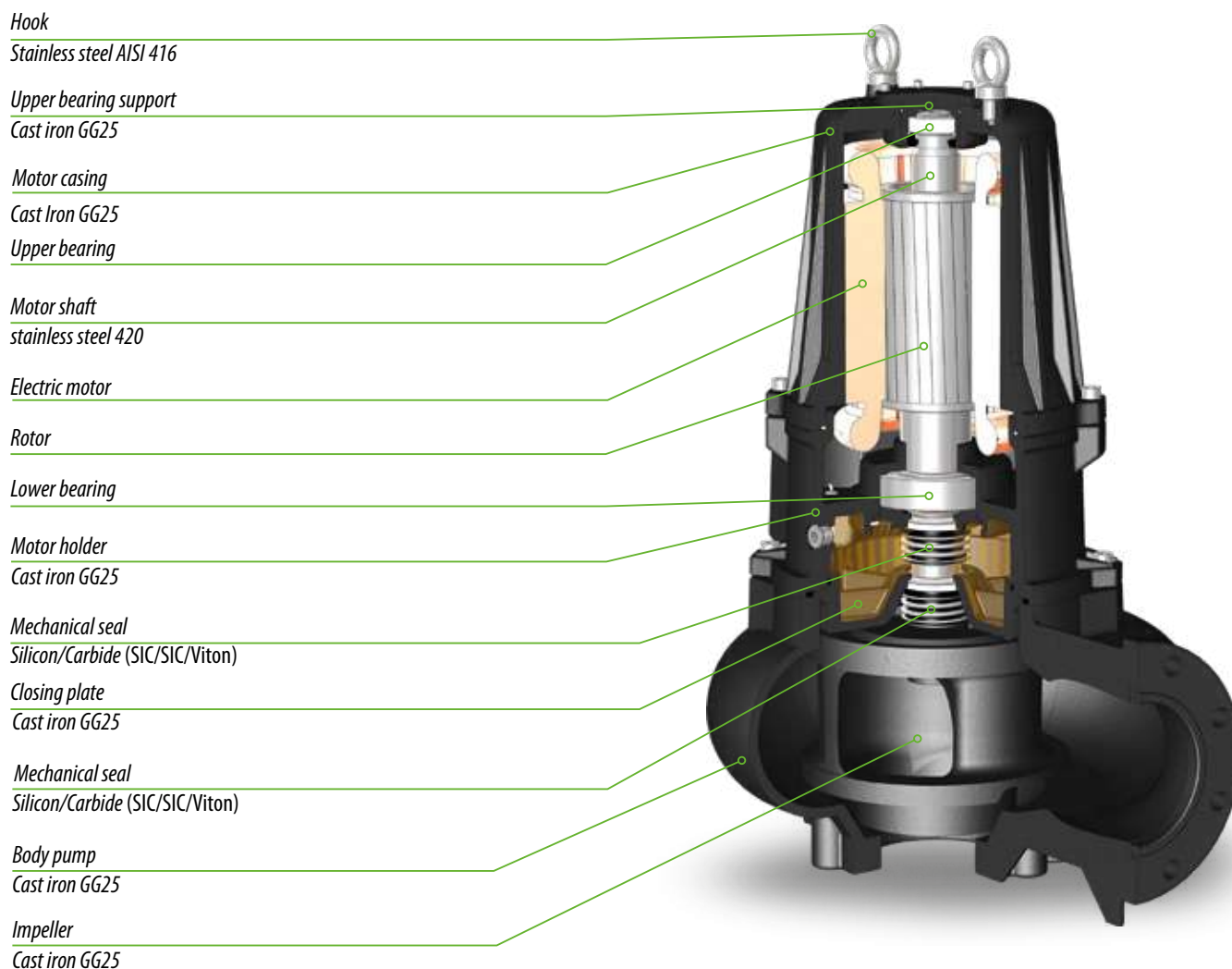

### Technology and Features

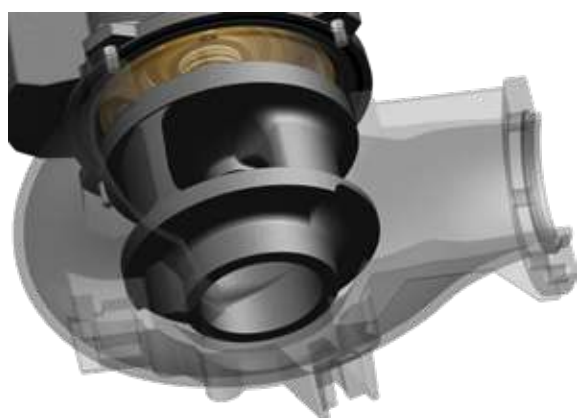

#### Impellers

This range of pump features close double channel impeller with excellent performance and free passage of solids up to 130 mm.



#### Explosion proof pumps



II 2G Ex db IIB T4 Gb  
Ex h IIB T4 Gb  
0° ~ Ta ~ 40°



EPT 17 ATEX 2703 X

These certificates grant for the safe use of the product in hazardous area in line with the stringent European and International standards ATEX/IECEx.



#### Seal leak detector

The seal leak detector is certified according to the norm EN 60079-0, EN 60079-1 (through safety barrier) and fitted standard on all series (not applicable with IECEx).



#### Bearings

The series is fitted with a cylindrical roller bearing (upper bearing) to absorb the thrust and vibration generated by the pump shaft.

### Horizontal Outlet DN150 PN16 - RPM 1450 1/min 4 poles

Picture for illustration purposes only



maximum pump efficiency

#### Performance Curve

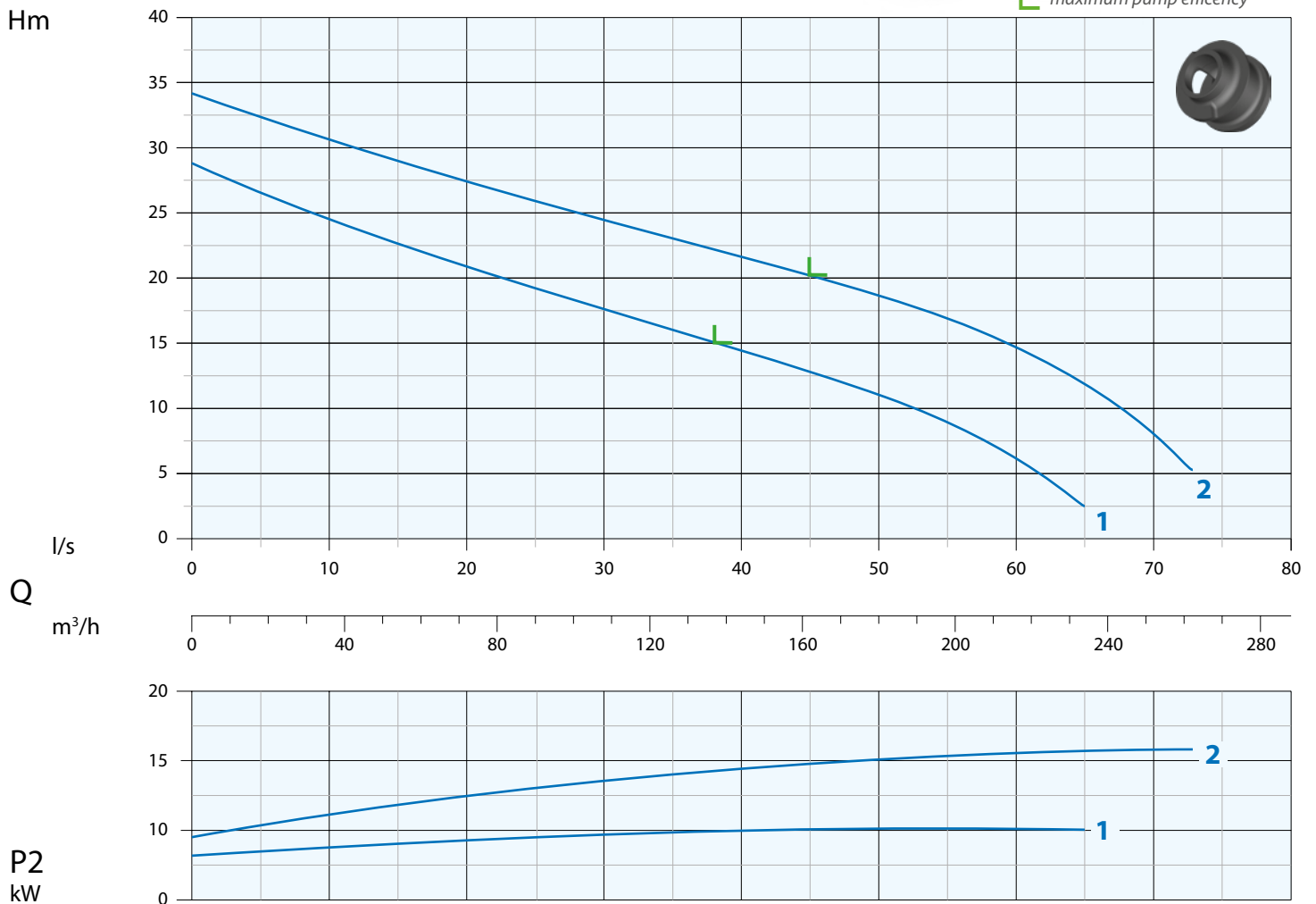

N°	Type	I/s	5	10	15	20	25	30	40	50	60	70
		l/m	300	600	900	1200	1500	1800	2400	3000	3600	4200
		m³/h	18	36	54	72	90	108	144	180	216	252
1	AT 150/4/200 C.260	mt	26,5	24	22,5	21	19	17,5	14,5	11	6	
2	AT 150/4/200 C.263	mt	32,5	31	28,5	27,5	26,5	24	21,5	18,5	15	7,5

N°	Type	EX	Delivery	Free Passage	kW		HP	R.P.M. 1/min	A		
					P1	P2			3 Phase - 400V		Hz
1	AT 150/4/200 C.260	•	DN150 PN16	80 mm	11,7	10	13,5	1450	21,3		50
2	AT 150/4/200 C.263	•			18,7	16	22,5		33,2		

• Available explosion proof pump with certifications:



EPT 17 ATEX 2703 X



Ex db IIB T4 Gb  
Ex h IIB T4 Gb  
0° Ta 40°

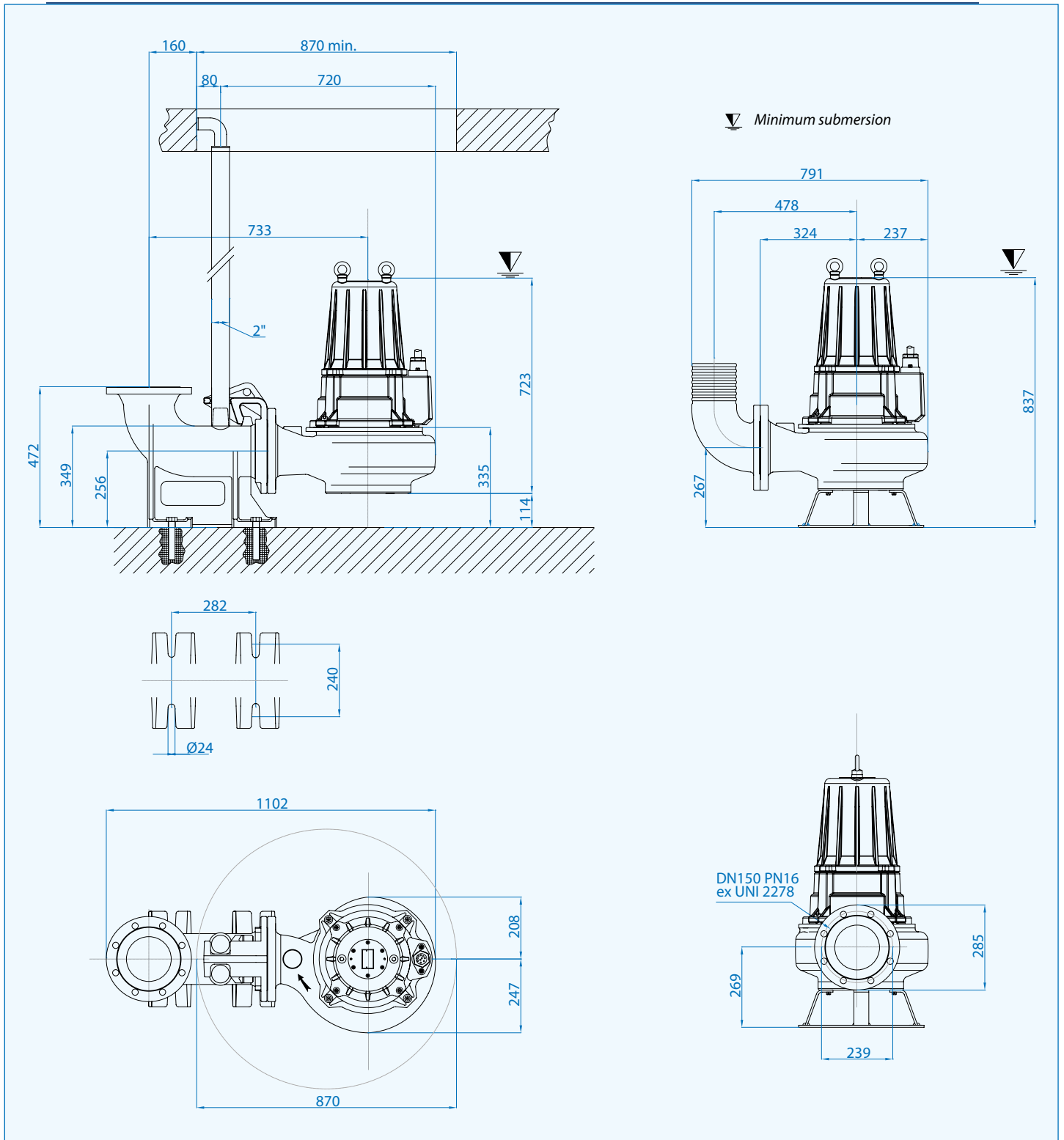

## Cables

Version	Phases	Cable	Cable cross section mm <sup>2</sup>	mt
Standard	3 ~ 400V	H07RN8F	10x2,5 Ø 23*	10
ATEX	Y-Δ	NSSHÖU-J	7x2,5+3x0,50 Ø 20*	10

\* Free terminals

## Packaging dimension

Type	X mm	Y mm	Z mm	Kg
AT 150/4/200 C.260	570	950	670	230
AT 150/4/200 C.263	570	950	670	256

Coordinate system diagram showing X, Y, and Z axes.

## Optional



Automatic coupling foot  
Type: B7



Flanged hose connection N4 Foot  
support P7



## Horizontal Outlet DN150 PN16 - RPM 1450 1/min 4 poles

Picture for illustration purposes only



maximum pump efficiency

### Performance Curve

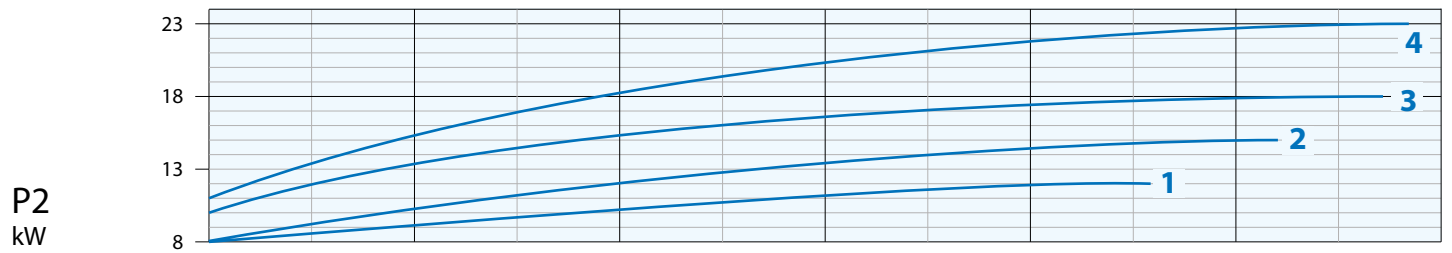
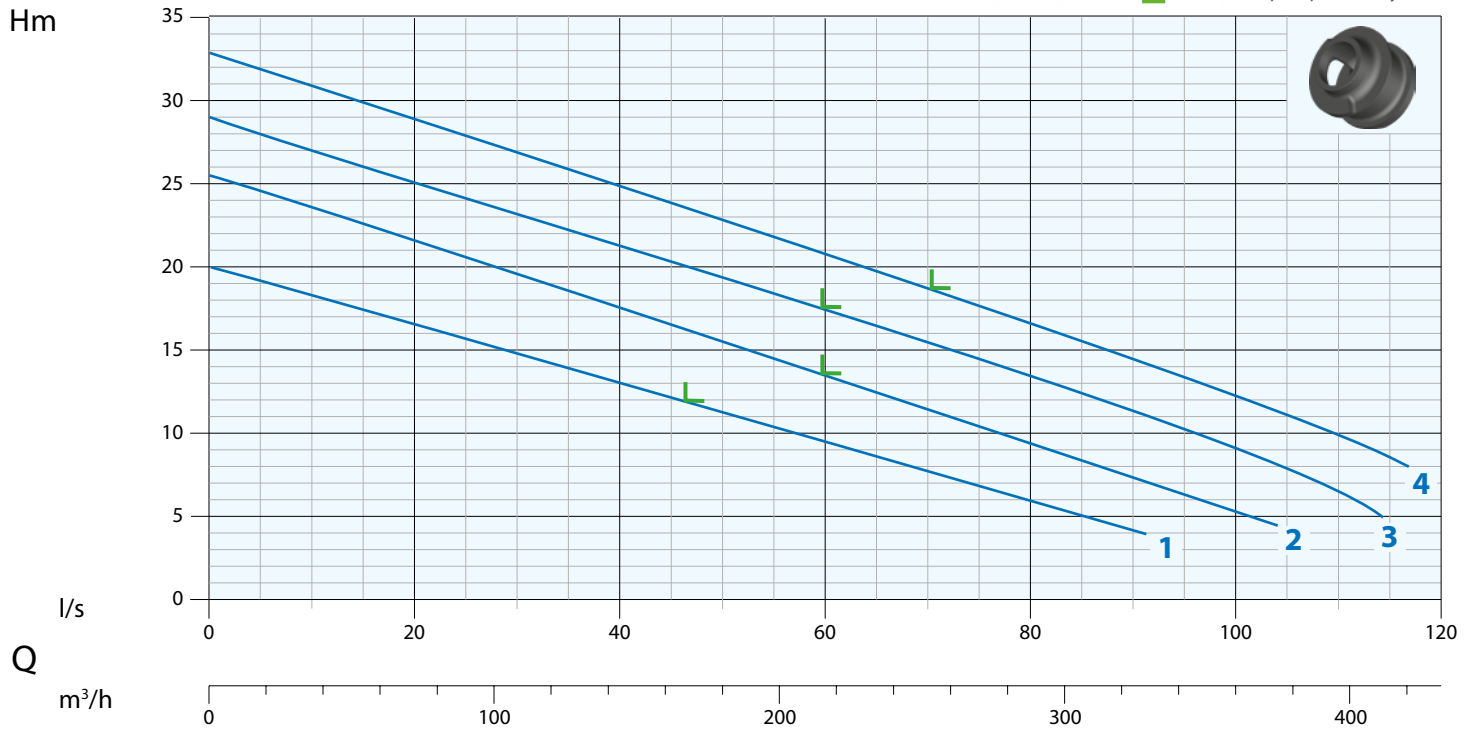

N°	Type	Flow (Q)										
		10 l/s 600 l/m 36 m³/h	20 1200 72	30 1800 108	40 2400 144	50 3000 180	60 3600 216	70 4200 252	80 4800 288	90 5400 324	110 6600 396	
1	AT 150/4/200 C.264	18	16,5	15	13	11	9,5	7,5	6	4		
2	AT 150/4/200 C.265	23,5	21,5	19,5	17,5	15,5	13,5	11,5	9,5	7		
3	AT 150/4/240 C.275	27	25	23	21	19,5	17,5	15,5	13,5	11	6,5	
4	AT 150/4/240 C.280	31	29	27	25	23	21	18,5	16,5	14,5	10	

N°	Type	EX	Delivery	Free Passage	kW			R.P.M. 1/min	A 3 Phase - 400V	Hz
					P1	P2	HP			
1	AT 150/4/200 C.264	•	DN150 PN16	110 mm	12,8	11	16	1450	23,4	50
2	AT 150/4/200 C.265	•			17,6	15	22		31,8	
3	AT 150/4/240 C.275	•		20,3	18	24	39,7			
4	AT 150/4/240 C.280	•		25,9	23	31	47,7			

• Available explosion proof pump with certifications:



Ex db IIB T4 Gb  
Ex h IIB T4 Gb  
0° Ta° 40°

EPT 17 ATEX 2703 X

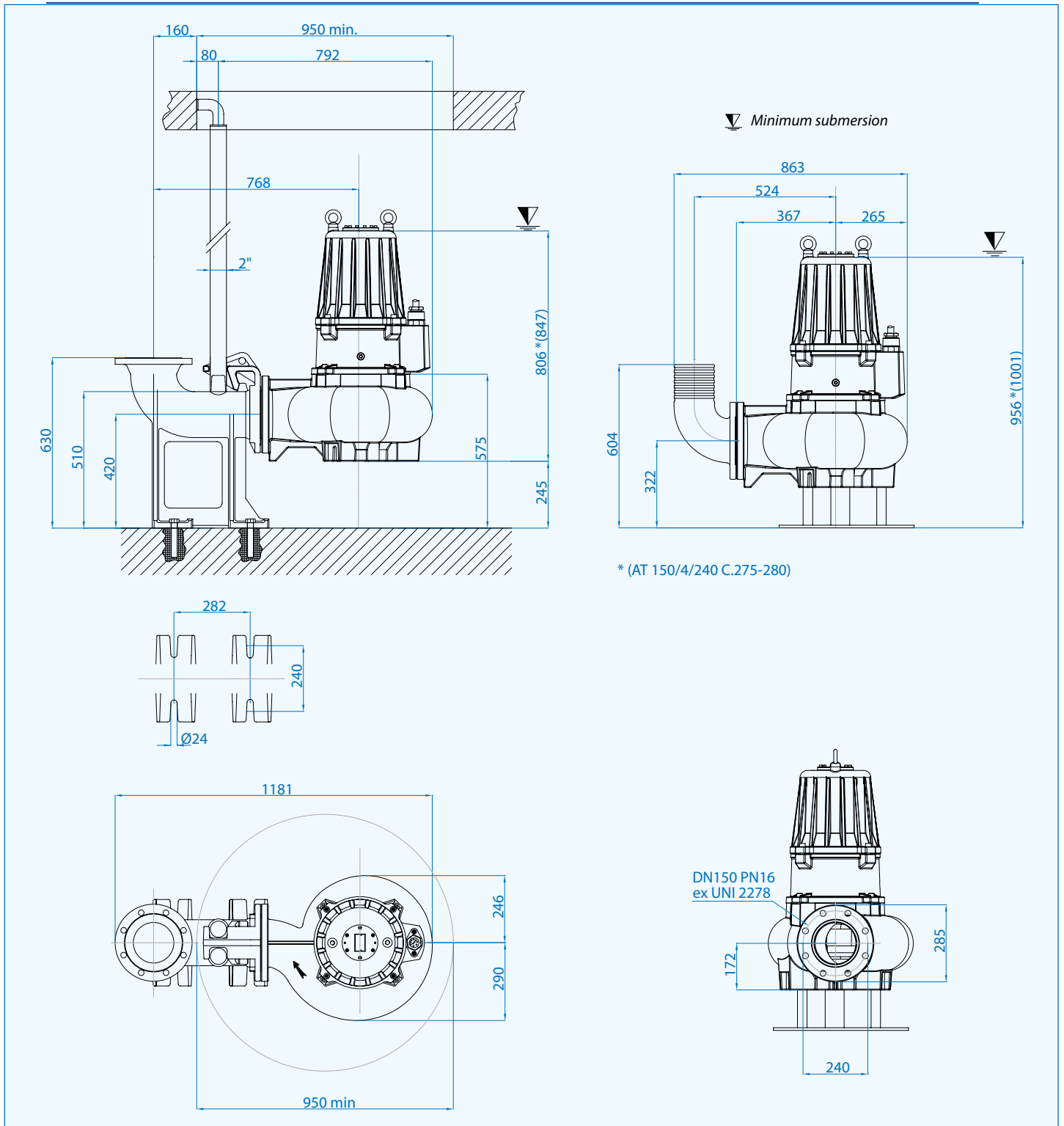

### Cables

Pumps	Version	Phases	Cable	Cable cross section mm <sup>2</sup>	mt
150/4/200	Standard	3 ~ 400V	H07RN8F	10x2,5 Ø23*	10
	ATEX	Y-Δ	NSSHÖU-J	7x2,5+3x0,50 Ø20*	10
150/4/240	Standard	3 ~ 400V	H07RN8F	7x4+3x1 Ø20,5*	10
	ATEX	Y-Δ	NSSHÖU-J	7x6+3x1 Ø24*	10

\* Free terminals

### Packaging dimension

Type	X mm	Y mm	Z mm	Kg
AT 150/4/200 C.264	570	950	670	260
AT 150/4/200 C.265				276
AT 150/4/240 C.275				308
AT 150/4/240 C.280				328

### Optional



Automatic coupling foot  
Type: B8



Flanged hose connection N4 Foot  
support P8

## Horizontal Outlet DN150 PN16 - RPM 1450 1/min 4 poles

Picture for illustration purposes only



maximum pump efficiency

### Performance Curve

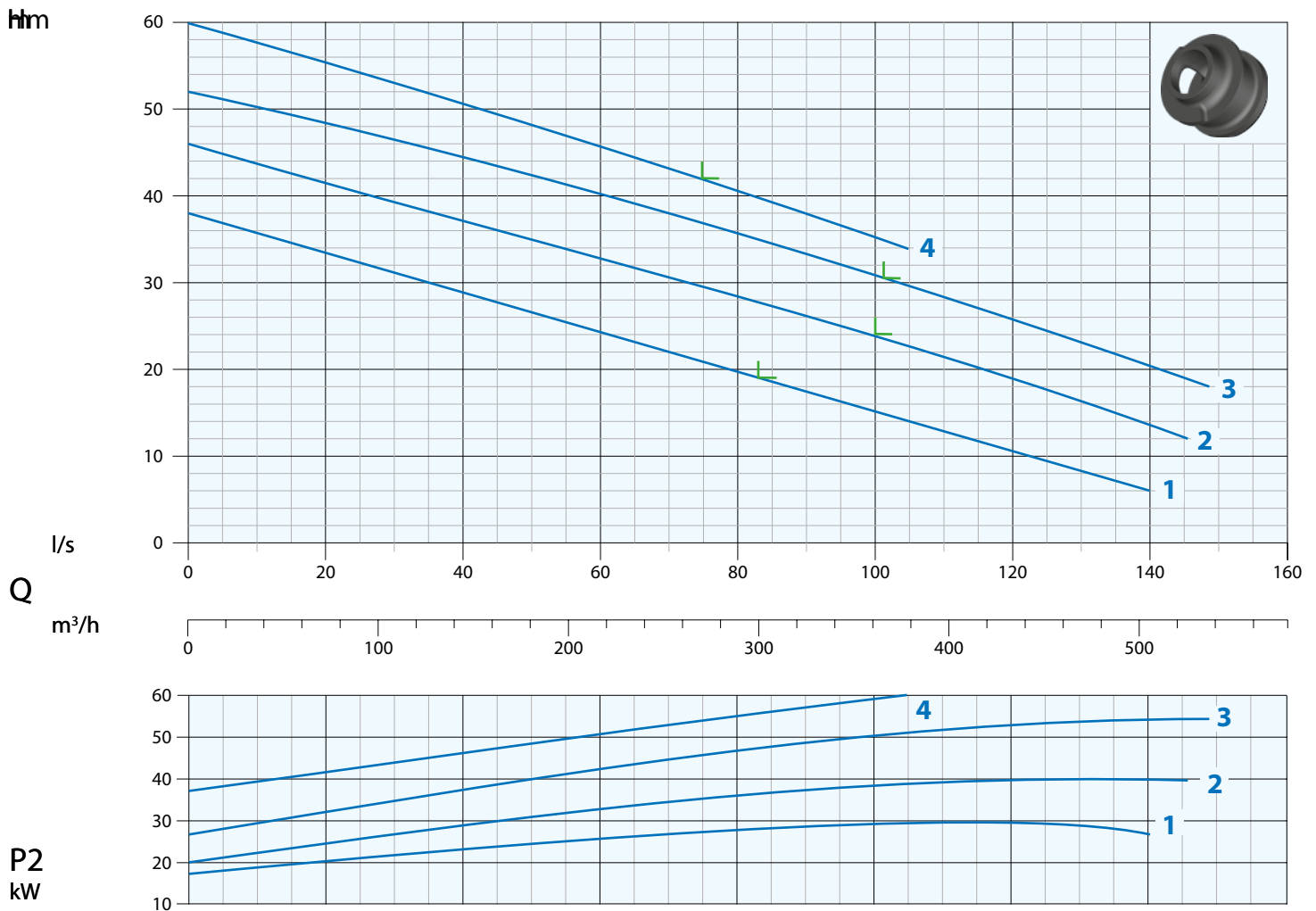

N°	Type	Flow Rate									
		10 l/s 600 l/m 36 m³/h	20 l/s 1200 l/m 72 m³/h	30 l/s 1800 l/m 108 m³/h	40 l/s 2400 l/m 144 m³/h	50 l/s 3000 l/m 180 m³/h	60 l/s 3600 l/m 216 m³/h	80 l/s 4800 l/m 288 m³/h	100 l/s 6000 l/m 360 m³/h	120 l/s 7200 l/m 432 m³/h	140 l/s 8400 l/m 504 m³/h
1	AT 150/4/340 C.285	36	34	31	29	26	24	20	15	10	6
2	AT 150/4/340 C.290	44	42	39	37	35	33	28	24	19,5	14
3	AT 150/4/340 C.295	50	48	46	44	42	40	36	31	26	20
4	AT 150/4/340 C.300	58	56	53	51	48	46	41			

N°	Type	Delivery	Free Passage	kW			R.P.M. 1/min	A 3 Phase - 400V	Hz
				P1	P2	HP			
1	AT 150/4/340 C.285	DN150 PN16	110 mm	33	30	40	1450	59	50
2	AT 150/4/340 C.290		120 mm	42	40	53,5		73,1	
3	AT 150/4/340 C.295		130 mm	54,6	51	61		98,6	
4	AT 150/4/340 C.300		140 mm	64	60	68		108,6	

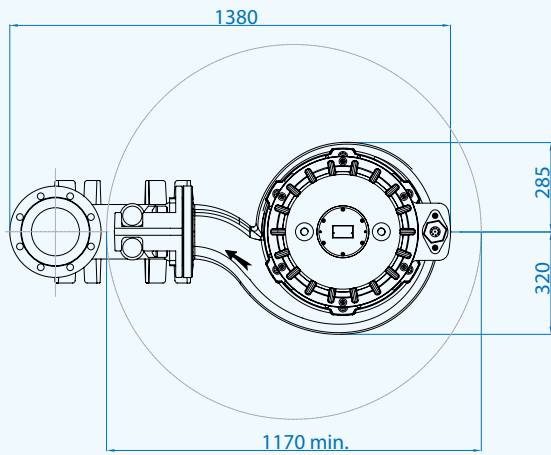
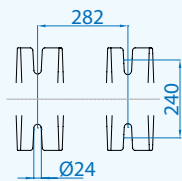
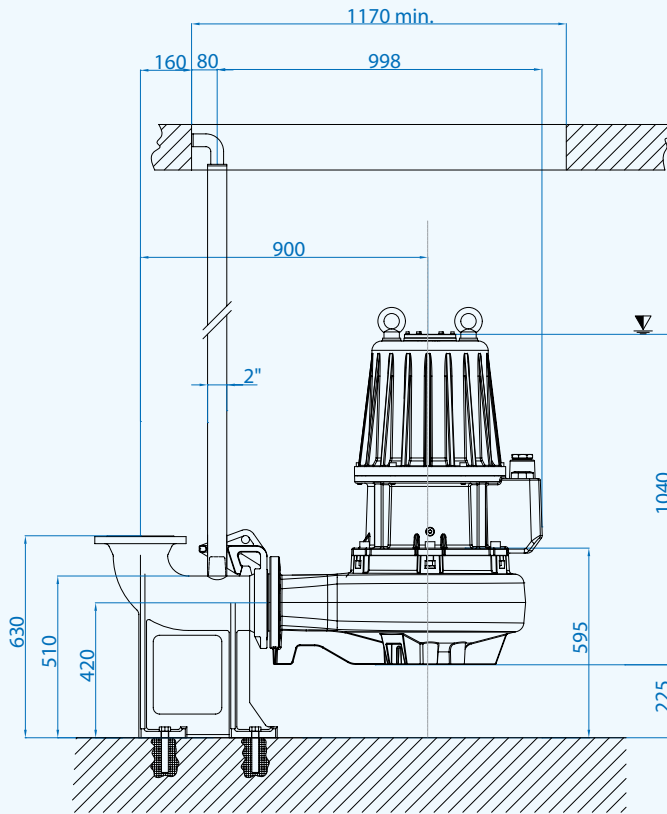

▽ Minimum submersion

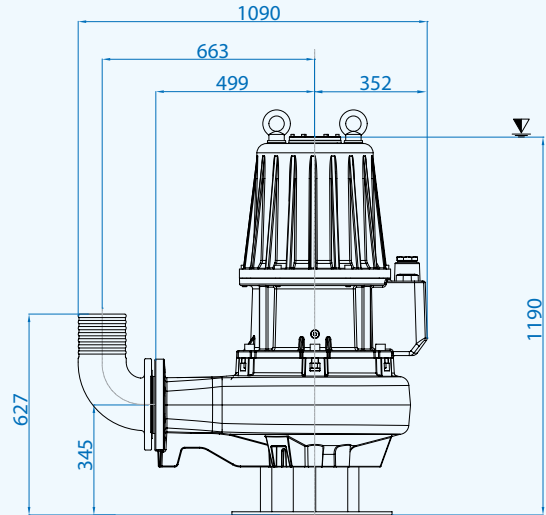

DN150 PN16  
ex UNI 2278

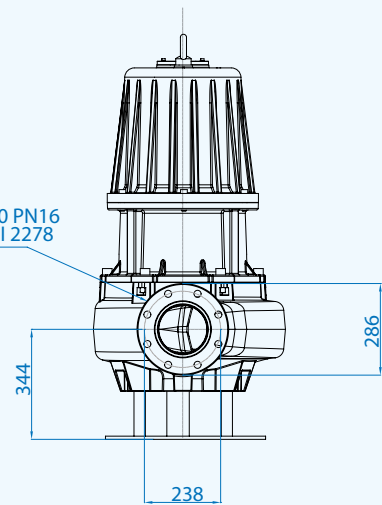

## Cables

Version	Phases	Cable	Cable cross section mm <sup>2</sup>	mt
Standard	3 ~ 400V Y-Δ	H07RN8F	7x10+5x1 Ø29*	10

\* Free terminals

## Packaging dimension

Tipo - Type	X mm	Y mm	Z mm	Kg
AT 150/4/340 C.285				550
AT 150/4/340 C.290	980	1310	730	585
AT 150/4/340 C.295				600
AT 150/4/340 C.300				600



## Optional



Automatic coupling foot  
Type: B8



Flanged hose connection N4 Foot  
support P8

## Horizontal Outlet DN200 PN10 - RPM 1450 1/min 4 poles

Picture for illustration purposes only



### Performance Curve

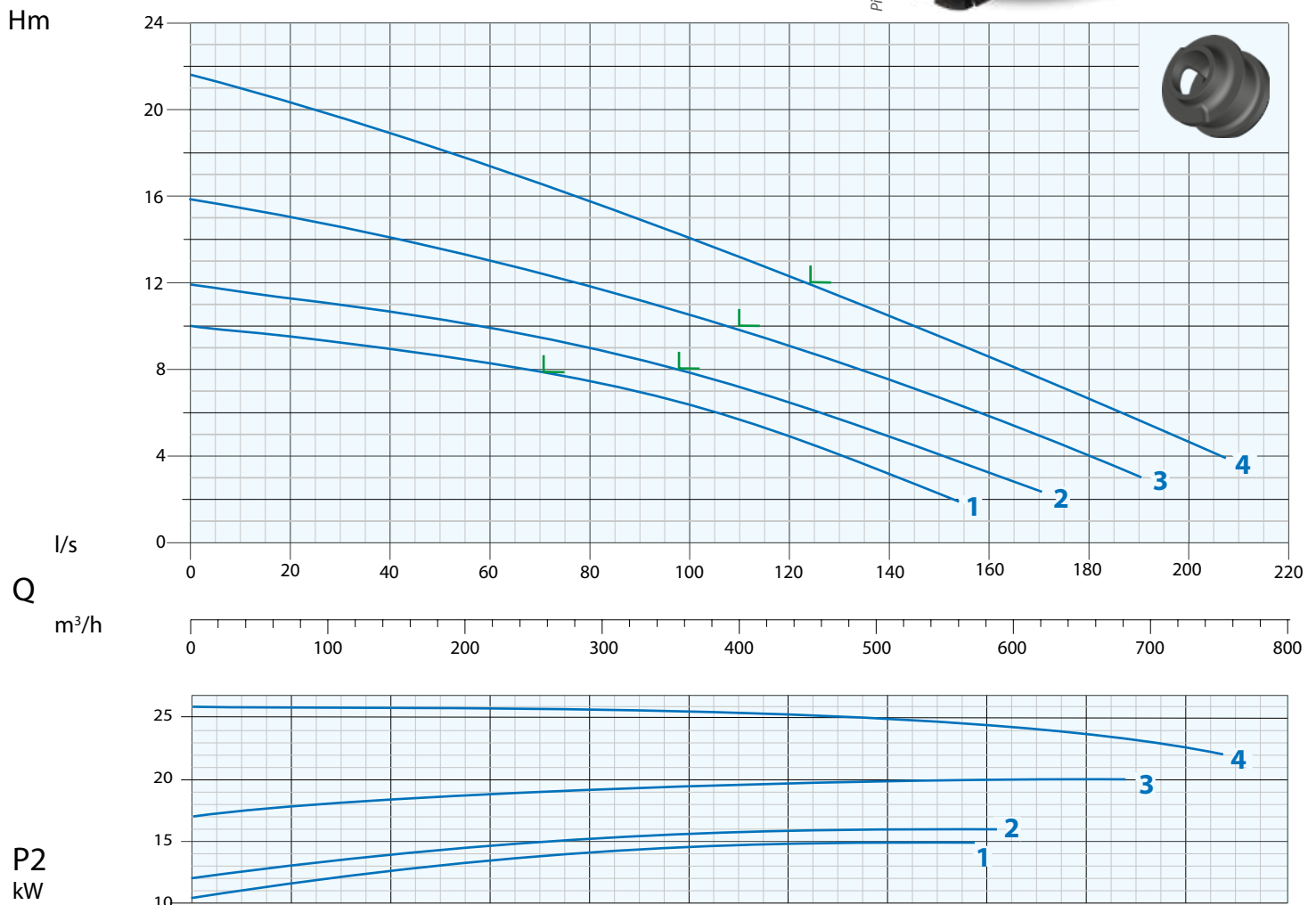

N°	Type	l/s l/m m³/h	20	40	60	80	100	120	140	160	180	200
			1200	2400	3600	4800	6000	7200	8400	9600	10800	12000
1	AT 200/4/200 C.265	mt	9,5	9	8,5	7,5	6,5	5	3			
2	AT 200/4/240 C.270		11,5	10,5	10	9	8	6,5	5	2,5		
3	AT 200/4/240 C.275		15	14	13	11,5	10,5	9	7,5	5	4	
4	AT 200/4/240 C.280		20	18,5	17	15,5	14	12	10,5	9	7	5

N°	Type	EX	Delivery	Free Passage	kW			R.P.M. 1/min	A 3 Phase - 400V	Hz
					P1	P2	HP			
1	AT 200/4/200 C.265	•	DN200 PN10	110 mm	18	15	20,4	1450	31,8	50
2	AT 200/4/240 C.270	•		110 mm	19,8	17	23,1		38,8	
3	AT 200/4/240 C.275	•		110 mm	22,6	20	27,2		41,4	
4	AT 200/4/240 C.280	•		110 mm	29,3	26	35,3		54,8	

• Available explosion proof pump with certifications:



EPT 17 ATEX 2703 X



Ex db IIB T4 Gb  
Ex h IIB T4 Gb  
0° - Ta - 40°

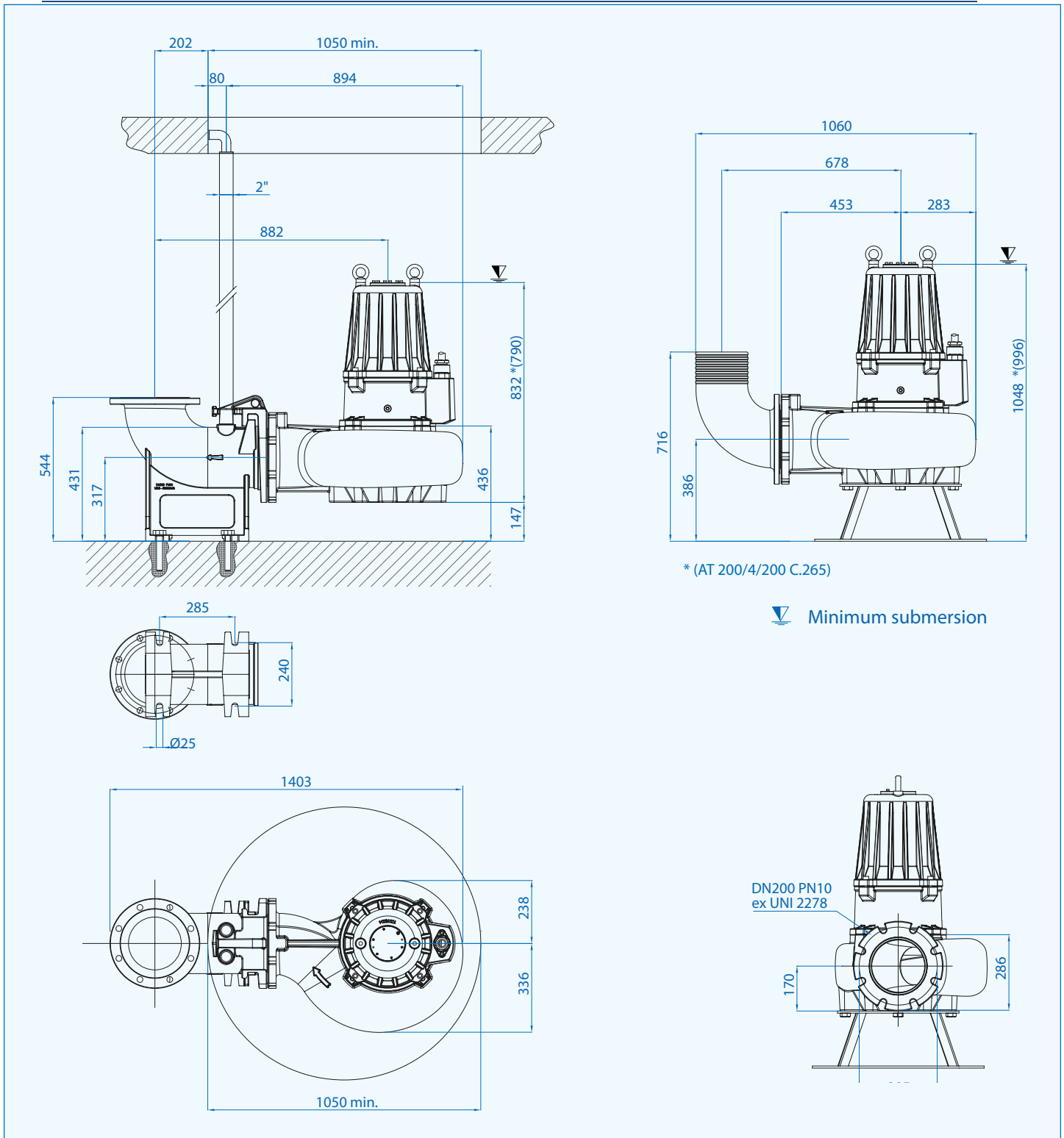

### Cables

Pumps	Version	Phases	Cable	Cable cross section mm <sup>2</sup>	mt
200/4/200	Standard	3 ~ 400V	H07RN8F	10x2,5 Ø23*	10
	ATEX	Y-Δ	NSSHÖU-J	7x2,5+3x0,50 Ø20*	10
200/4/240	Standard	3 ~ 400V	H07RN8F	7x4+3x1 Ø20,5*	10
	ATEX	Y-Δ	NSSHÖU-J	7x6+3x1 Ø24*	10

\* Free terminals

### Packaging dimension

Type	X mm	Y mm	Z mm	Kg
AT 200/4/200 C.265				296
AT 200/4/240 C.270	980	1310	730	340
AT 200/4/240 C.275				341
AT 200/4/240 C.280				343

### Optional



Automatic coupling foot  
Type: B9



Flanged hose connection N6 Foot  
support P9

### Horizontal Outlet DN200 PN10 - RPM 960 1/min 6 poles

Picture for illustration purposes only



#### Performance Curve

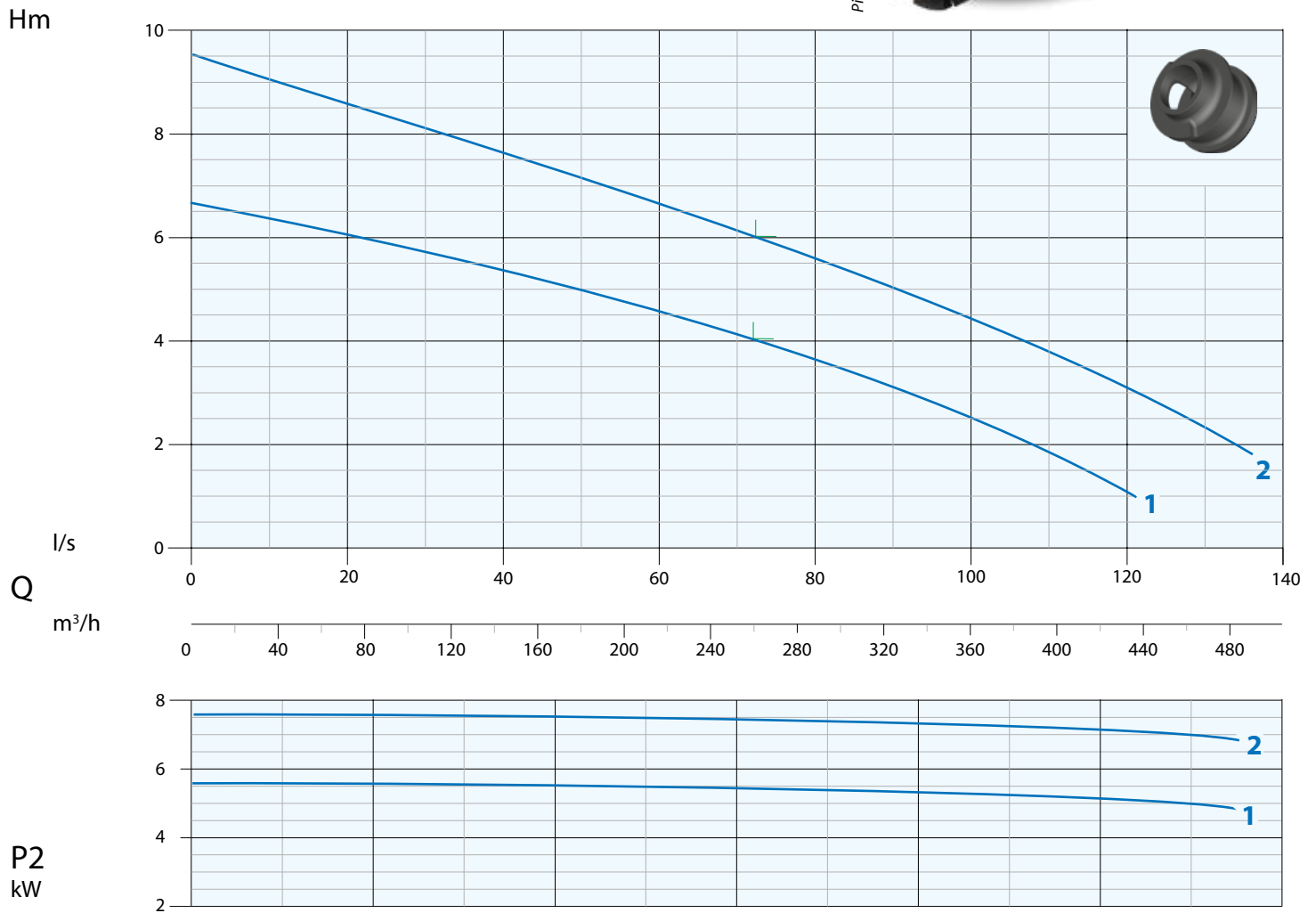

N°	Type	l/s	10	20	30	40	50	60	80	100	120	130
			l/m	600	1200	1800	2400	3000	3600	4800	6000	720
		m³/h	36	72	108	144	144	216	288	360	432	468
1	AT 200/6/240 C.275	mt	6,5	36	5,5	31	5	26	24	15	6	
2	AT 200/6/240 C.280		9	44	8	39	7	35	33	24	14	2,5

N°	Type	Delivery	EX	Free Passage	kW		HP	R.P.M. 1/min	A		Hz
					P1	P2			3 Phase - 400V		
1	AT 200/6/240 C.275	DN200 PN10	•	110 mm	6,6	5,5	7,5	960	14,2	17,5	50
2	AT 200/6/240 C.280				9	7,5	10				

• Available explosion proof pump with certifications:



EPT 17 ATEX 2703 X



Ex db IIB T4 Gb  
Ex h IIB T4 Gb  
0° Ta ~ 40°

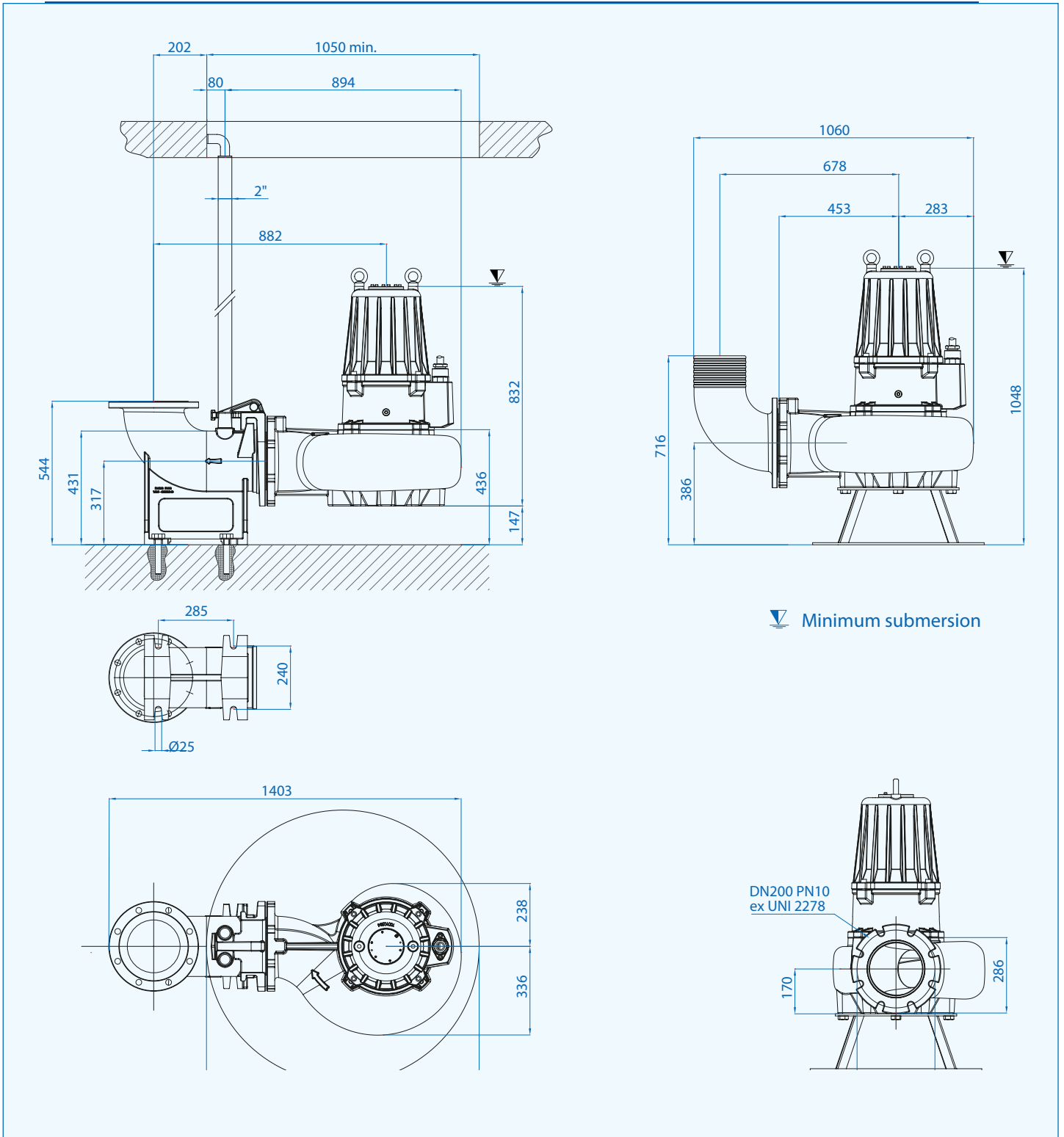

### Cables

Pumps	Version	Phases	Cable	Cable cross section mm <sup>2</sup>	mt
200/6/240	Standard	3 ~ 400V	H07RN8F	10x2,5 $\varnothing 23^*$	10
	ATEX	Y- $\Delta$	NSSHÖU-J	7x2,5+3x0,50 $\varnothing 20^*$	10

\* Free terminals

### Packaging dimension

Type	X mm	Y mm	Z mm	Kg
AT 200/6/240 C.275	980	1310	730	320
AT 200/6/240 C.280				322

### Optional



Automatic coupling foot  
Type: B9



Flanged hose connection N6 Foot  
support P9



# Submersible electro pumps with centrifugal twin channel impeller

Power:	<b>12÷42 kW</b>
Delivery:	<b>DN80-100</b>



## Designation

**ATH-EX 100 - 2 / 250**

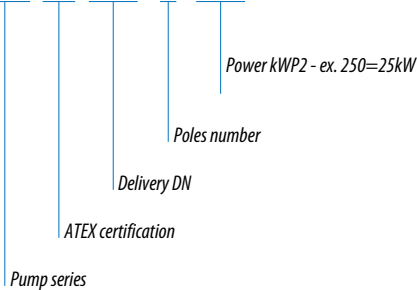

## Applications

The ATH 2 poles Series is used to move large volumes of clear water or light sewage with high performance.

Applications: water treatment plants, industrial plants, airports, hospitals and civil applications and agricultural irrigation.

## Characteristic

All main components are made of grey cast iron GG25. Two individual mechanical seals (motor side in the oil chamber, impeller side in contact with the liquid) and high quality parts, ensure the perfect functioning and reliability of the product.

## Motor range

- Squirrel cage motor at 2 poles
- Thermal protection T1 and T2 embedded in the motor winding (to be wired to the three pole contactor in the control panel)
- Class F insulation (155°C)
- IP 68 protection

## Motor cooling

The cooling of the motor is ensured by the liquid where the pump is submerged.

## Limits of use

- Max. permissible liquid temperature: 40°C with pump fully submerged
- On request, special version (excluded ATEX) to withstand liquid temperature up to 60°C with pump fully submerged, no S1 service
- Maximum depth of immersion: 20 mt.
- Permissible pH value: 6-10
- Hydraulic features suitable for liquids with density <math>< 1,1 \text{ kg/dm}^3</math>
- Allowed voltage: 400/690V $\pm$ 5%
- Allowed frequency: 50Hz $\pm$ 2%

## Performance Overview

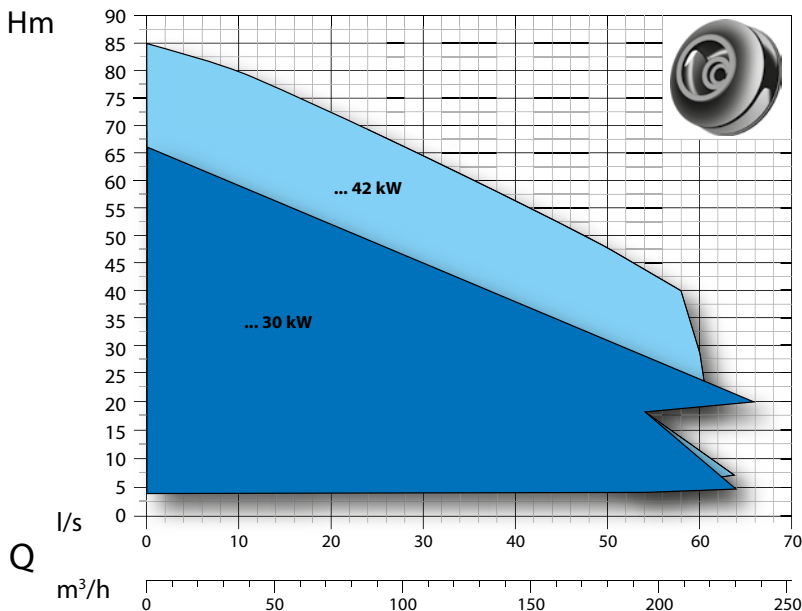

## Curves Identification

- DN80
- DN100

## Norms

According to ISO 9906:2012 3B2

## List of components and materials

Chain ring

Stainless steel AISI 416

Motor casing

Cast Iron GG25

Upper bearing support

Cast Iron GG25

Upper bearing

Motor shaft

Stainless steel AISI 420

Electric motor

Rotor

Lower bearing

Motor holder

Cast iron GG25

Mechanical seal

Silicon/Carbide (SiC/SiC/Viton)

Mechanical seal

Silicon/Carbide (SiC/SiC/Viton)

Body pump

Cast Iron GG25

Impeller

Cast iron GG25



## Technology and Features



### Impellers

The ATH centrifugal double-channel impeller are suitable for pumping large flow at very high pressure with free passage of solids up to 45 mm.



### Explosion proof pumps



EPT 17 ATEX 2703 X



Ex db IIB T4 Gb  
Ex h IIB T4 Gb  
0° ~ Ta ~ 40°

These certificates grant for the safe use of the product in hazardous area in line with the stringent European and International standards ATEX/IECEx.



### Seal leak detector

The seal leak detector is certified according to the norm EN 60079-0, EN 60079-1 (through safety barrier) and fitted standard on all series (not applicable with IECEx).



### Bearings

The series is fitted with a cylindrical roller bearing (upper bearing) to absorb the thrust and vibration generated by the pump shaft.

## Horizontal Outlet DN80 PN16 - RPM 2850 1/min 2 poles

Picture for illustration purposes only



L maximum pump efficiency

### Performance Curve

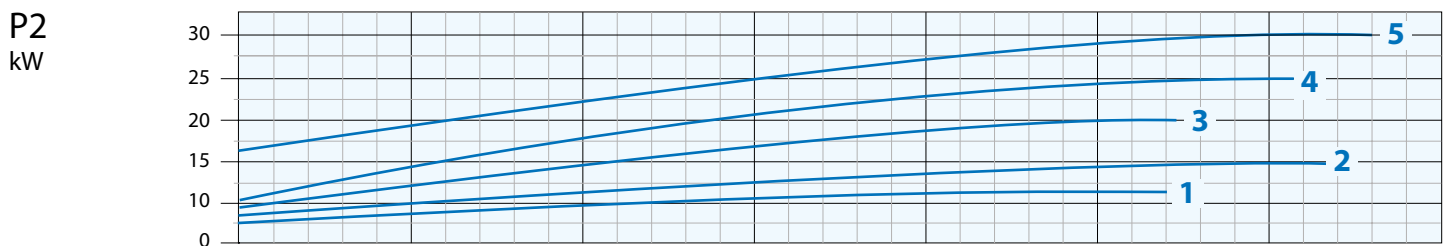
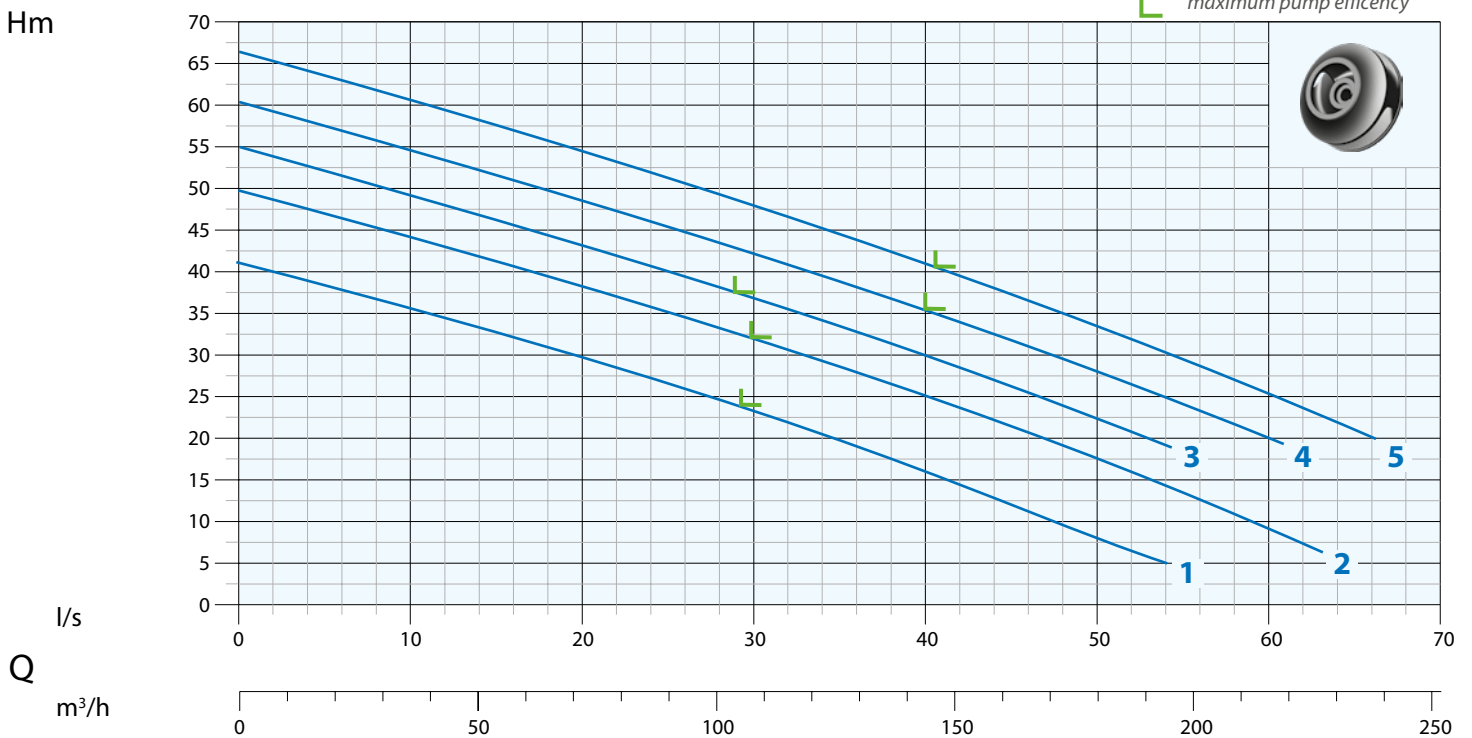

N°	Type	Flow Rate (Q)										
		l/s	6	10	20	30	40	44	50	54	60	62
		l/m	360	600	1200	1800	2400	2640	3000	3240	3600	3720
		m³/h	21,6	36	72	108	144	158,4	180	194,4	216	223,2
1	ATH 80-2/120	mt	37,5	35	30	22,5	16,5	12,5	7,5	5		
2	ATH 80-2/150		47	44	38	32,5	25	22,5	17,5	14	8	7,5
3	ATH 80-2/200		52	49	43	37	30	27,5	22,5	19		
4	ATH 80-2/250		57	55	48	42,5	35	32,5	28	25	20	
5	ATH 80-2/300		62,5	60	55	47,5	41,5	37,5	33	30	25	23

N°	Type	EX	Delivery	Free Passage	kW		HP	R.P.M. 1/min	A		Hz
					P1	P2			3 Phase - 400V		
1	ATH 80-2/120	•	DN80 PN16	33 mm	13,8	12	16	2850	23		50
2	ATH 80-2/150	•			18,5	15	20		29,7		
3	ATH 80-2/200	•		25,4	20	27	41,5				
4	ATH 80-2/250	•		29,9	25	34	48,4				
5	ATH 80-2/300	•		34	30	41	54,9				

• Available explosion proof pump with certifications:



Ex db IIB T4 Gb  
Ex h IIB T4 Gb  
0° Ta ~ 40°

EPT 17 ATEX 2703 X

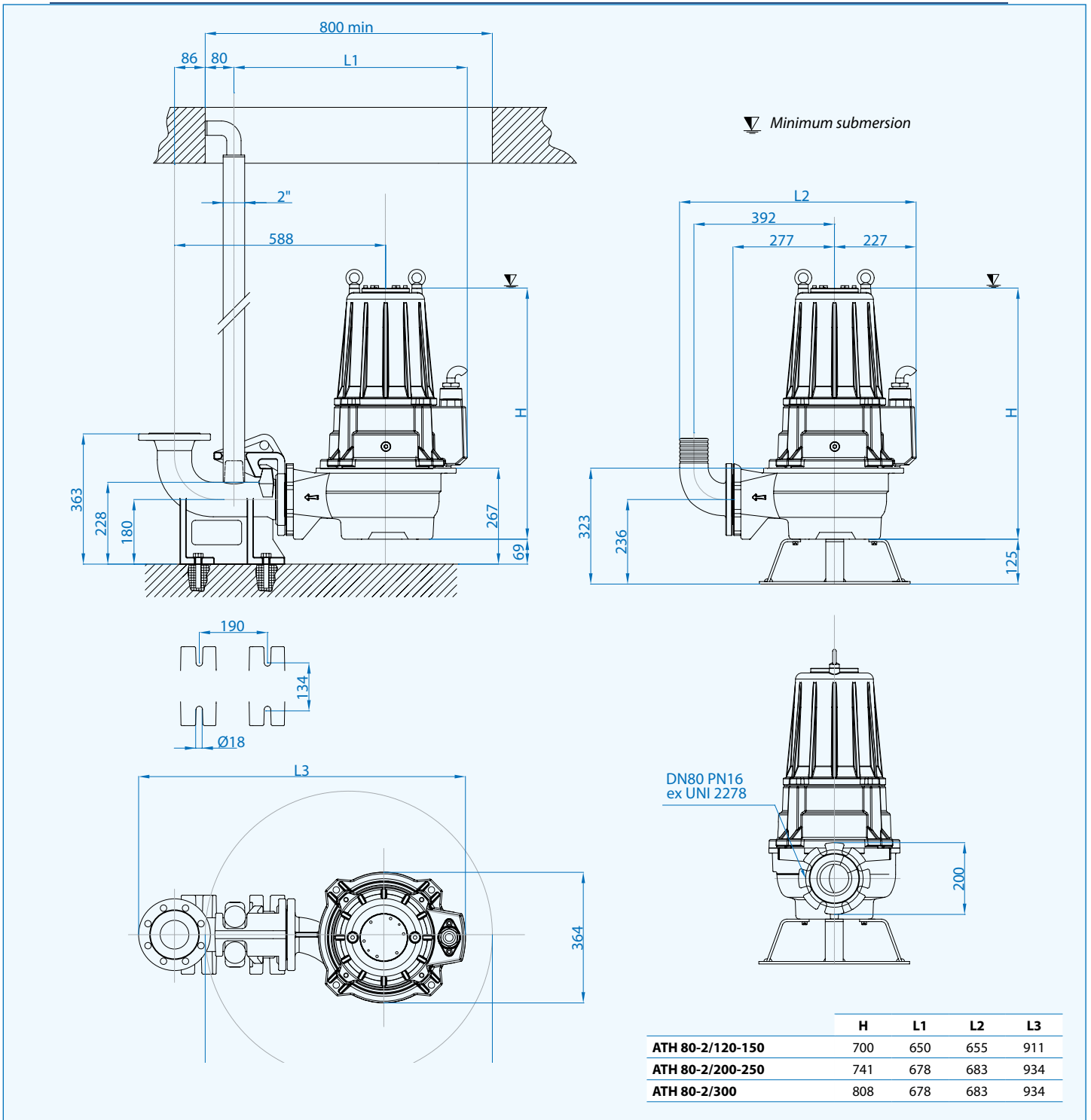

## Cables

Pumps	Version	Phases	Cable	Cable cross section mm <sup>2</sup>	mt
<b>80-2/120-150</b>	Standard	3 ~ 400V	H07RN8F	10x2,5 Ø23*	10
	ATEX	Y-Δ	NSSHÖU-J	7x2,5+3x0,50 Ø20*	10
<b>80-2/200-250</b>	Standard	3 ~ 400V	H07RN8F	7x4+3x1 Ø20,5*	10
	ATEX	Y-Δ	NSSHÖU-J	7x6+3x1 Ø24*	10
<b>80-2/300</b>	Standard	3 ~ 400V	NSSHÖU-J	7x6+3x1 Ø24*	10
	ATEX	Y-Δ	NSSHÖU-J	7x6+3x1 Ø24*	10

\* Free terminals

## Packaging dimension

Type	X mm	Y mm	Z mm	Kg
<b>ATH 80-2/120</b>				190
<b>ATH 80-2/150</b>				200
<b>ATH 80-2/200</b>	510	860	420	262
<b>ATH 80-2/250</b>				250
<b>ATH 80-2/300</b>				293

## Optional



Automatic coupling foot  
Type: DUTY 80 and B5



Flanged hose connection N2  
Foot support P7

## Horizontal Outlet DN100 PN16 - RPM 2850 1/min 2 poles

Immagine a solo scopo illustrativo  
Image for illustration purposes only



### Performance Curve

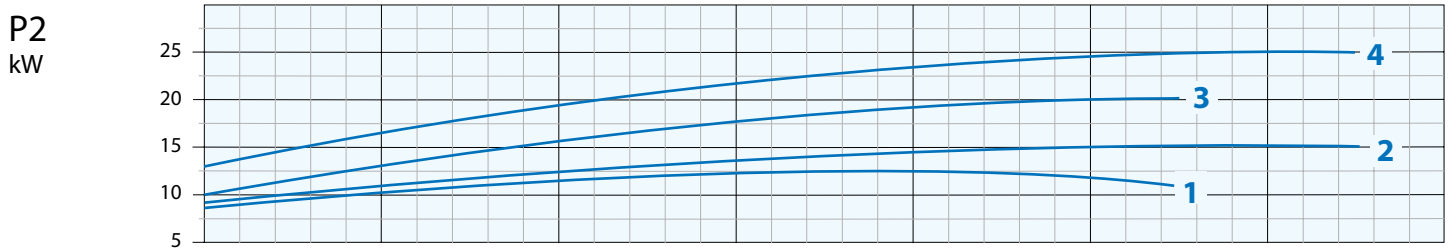
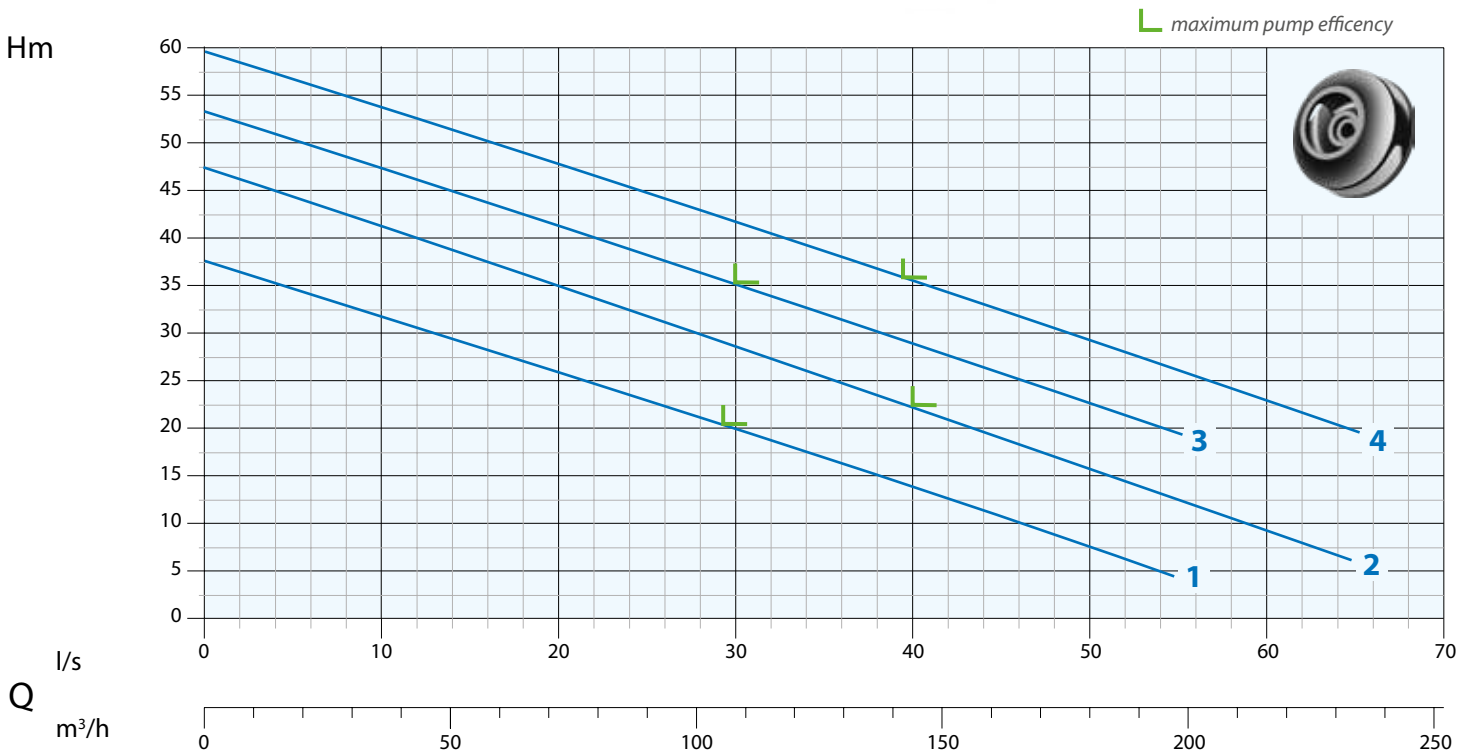

N°	Type	Flow (Q)										
		l/s	6	10	20	30	40	44	50	54	60	62
		l/m	360	600	1200	1800	2400	2640	3000	3240	3600	3720
		m³/h	21,6	36	72	108	144	158,4	180	194,4	216	223,2
1	ATH 100-2/120	mt	34	32	26	20	14	11	7,5	5		
2	ATH 100-2/150		44	41,5	35	28	22,5	20	16,5	13	9	7,5
3	ATH 100-2/200		50	47,5	41,5	35	28,5	27,5	23,5	20		
4	ATH 100-2/250		57	53,5	47,5	42	35	32,5	29	27	22,5	21,5

N°	Type	EX	Delivery	Free Passage	kW		HP	R.P.M. 1/min	Poli Poles	A		
					P1	P2				3 Phase - 400V		Hz
1	ATH 100-2/120	•	DN100 PN16	33 mm	13,8	12	16	2850	2	23,3		50
2	ATH 100-2/150	•			18,3	15	20	2850		29,5		
3	ATH 100-2/200	•		40 mm	26,1	20	27	2850		42,6		
4	ATH 100-2/250	•			30,5	25	34	2850		49,6		

• Available explosion proof pump with certifications:



Ex db IIB T4 Gb  
Ex h IIB T4 Gb  
0° - Ta ~ 40°

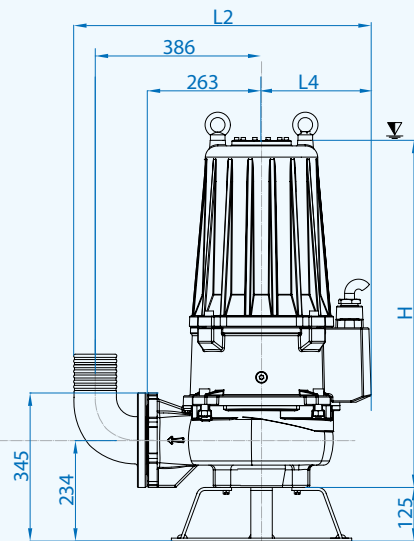
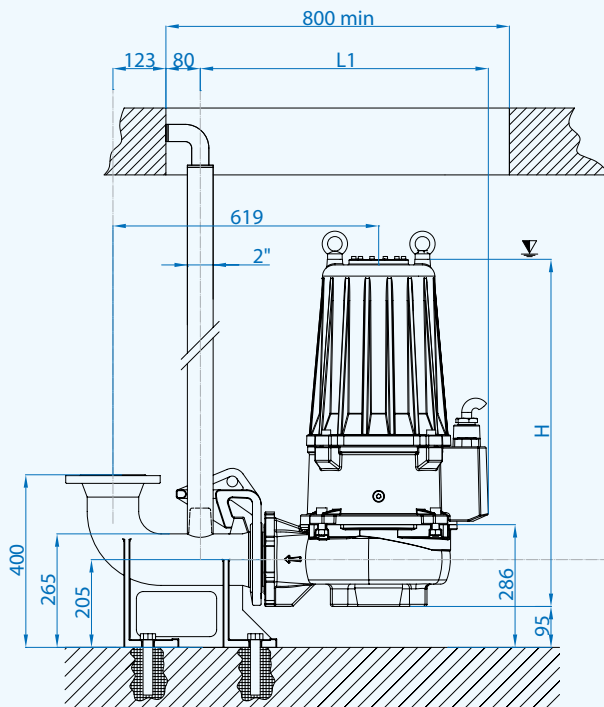

▽ Sommergenza minima  
Minimum submersion

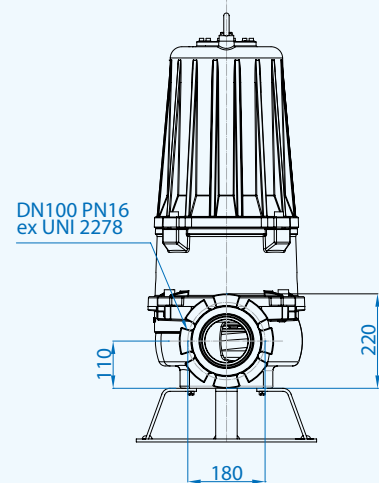
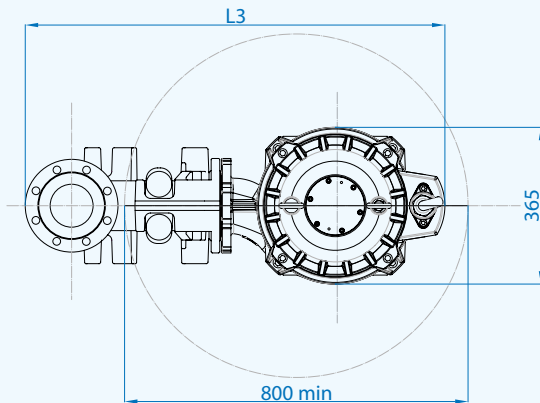
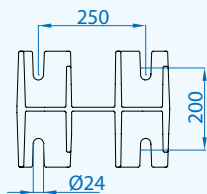

	H	L1	L2	L3	L4
ATH 100-2/120-150	693	734	663	949	227
ATH 100-2/200-250	734	671	693	977	257

## Cables

Pumps	Version	Phases	Cable	Cable cross section mm <sup>2</sup>	mt
100-2/120-150	Standard	3 ~ 400V	H07RN8F	10x2,5 Ø23*	10
	ATEX	Y-Δ	NSSHÖU-J	7x2,5+3x0,50 Ø20*	10
100-2/200-250	Standard	3 ~ 400V	H07RN8F	7x4+3x1 Ø20,5*	10
	ATEX	Y-Δ	NSSHÖU-J	7x6+3x1 Ø24*	10

\* Free terminals

## Packaging dimension

Type	X mm	Y mm	Z mm	Kg
ATH 100-2/120	510	860	420	190
ATH 100-2/150				200
ATH 100-2/200				247
ATH 100-2/250				250

## Optional



Automatic coupling foot  
Type: DUTY 100 and B6



Flanged hose connection N3  
Foot support P7

## Horizontal Outlet DN100 PN16 - RPM 2900 1/min 2 poles

### Performance Curve

Picture for illustration purposes only



maximum pump efficiency

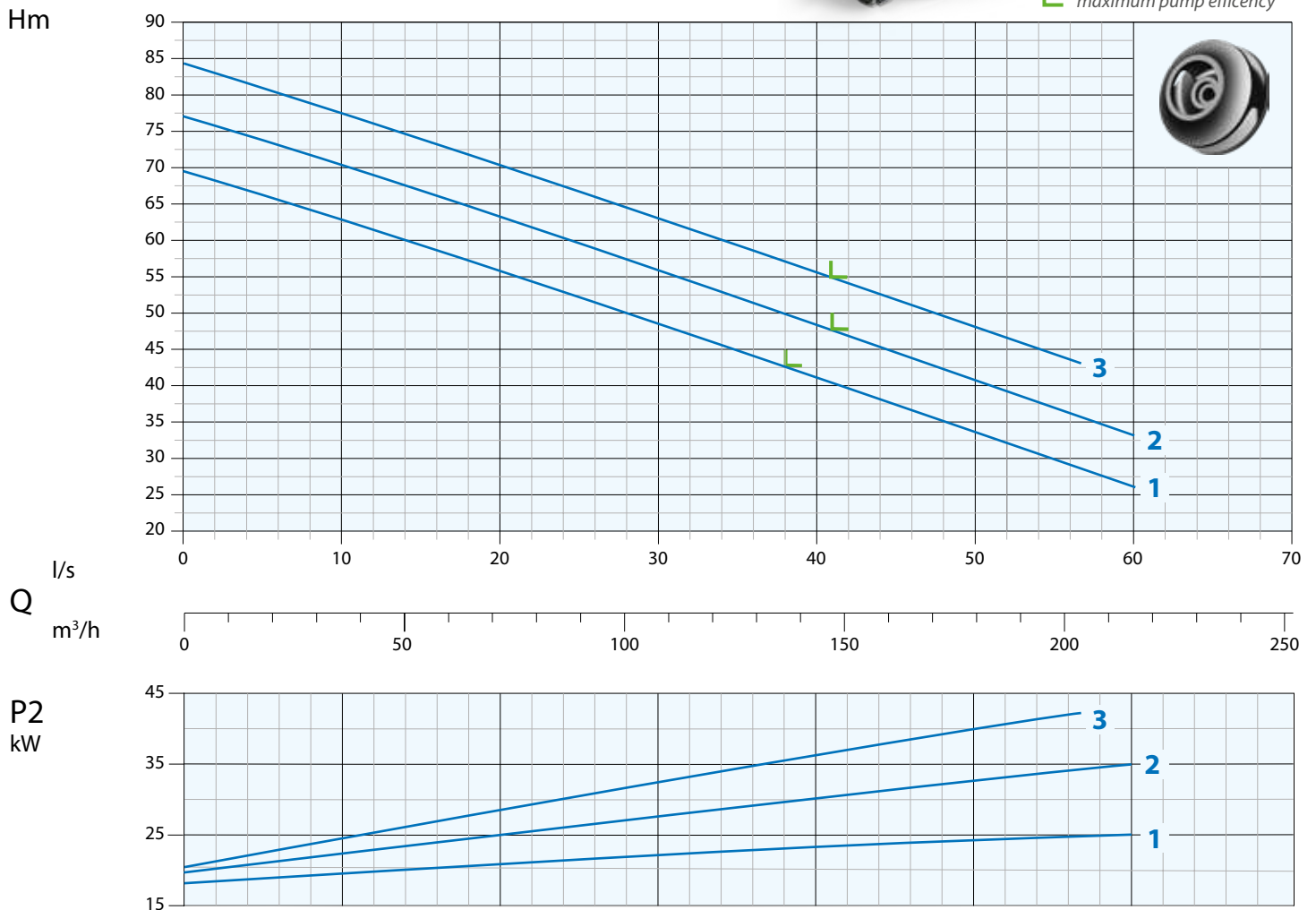

N°	Type		I/s	6	10	20	30	34	40	44	50	54	60
			l/m	360	600	1200	1800	2040	2400	2640	3000	3240	3600
			m³/h	21,6	36	72	108	122,4	144	158,4	180	194,4	216
1	ATH 100-2/350	mt		65	62,5	56	48	45	42	37,5	33	30	27
2	ATH 100-2/400			72,5	70	62,5	56,5	52,5	48	45	41	37,5	33
3	ATH 100-2/420			80	77,5	70	62,5	60	55	52,5	47,5	45	

N°	Type	EX	Delivery	Free Passage	kW			R.P.M. 1/min	A	Hz
					P1	P2	HP		3 Phase - 400V	
1	ATH 100-2/350	•	DN100 PN16	45 mm	40,6	35	47,5	2900	64,5	50
2	ATH 100-2/400	•			48,4	40	54		76,1	
3	ATH 100-2/420	•			51,8	42	57		81,4	

• Available explosion proof pump with certifications:



EPT 17 ATEX 2703 X



Ex db IIB T4 Gb  
Ex h IIB T4 Gb  
0° - Ta - 40°

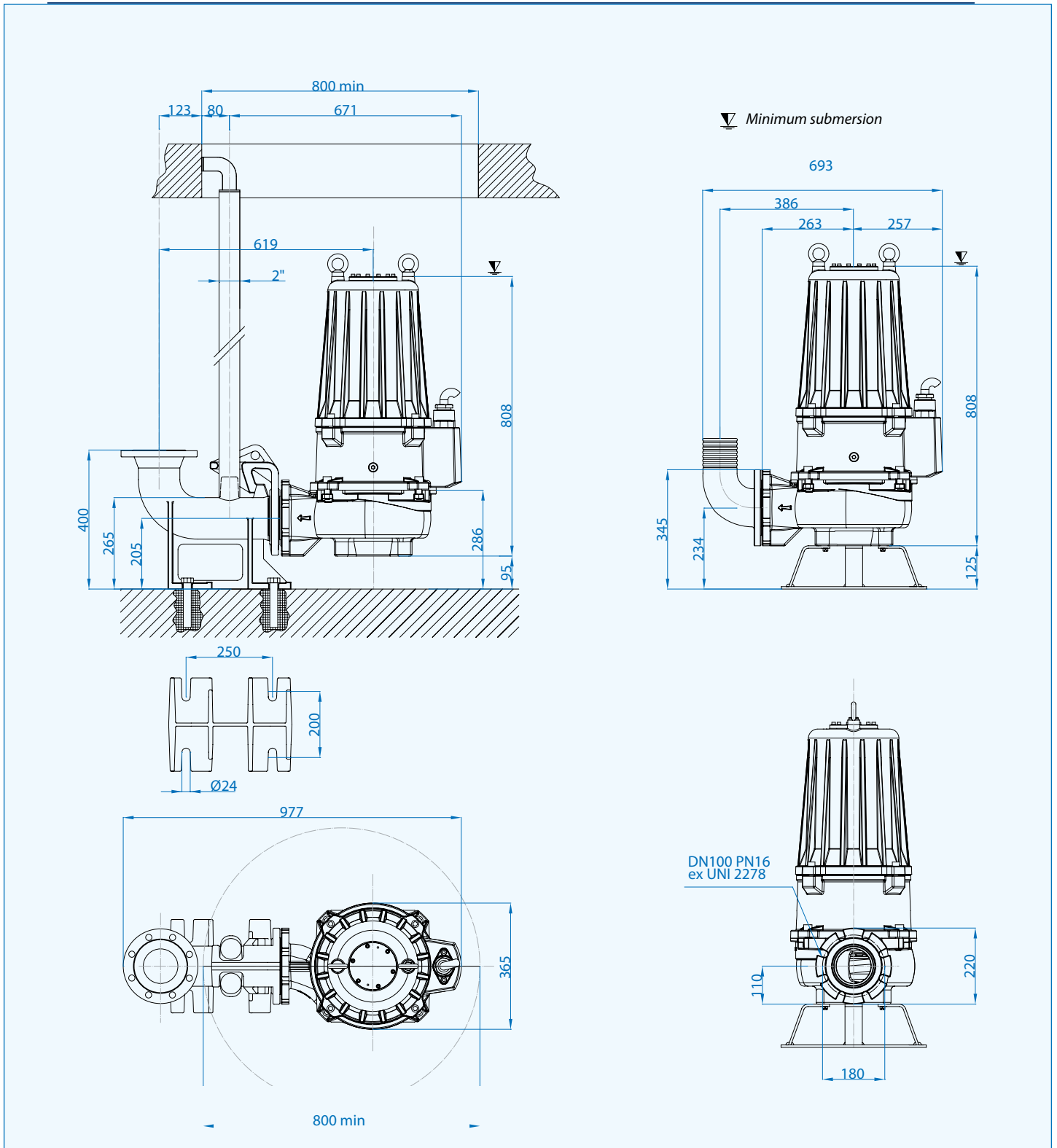

## Cables

Version	Phases	Cable	Cable cross section mm <sup>2</sup>	mt
Standard	3 ~ 400V	NSSHÖU-J	7x6+3x1 Ø24*	10
ATEX	Y-Δ	NSSHÖU-J	7x6+3x1 Ø24*	10

\* Free terminals

## Packaging dimension

Type	X mm	Y mm	Z mm	Kg
ATH 100-2/350				295
ATH 100-2/400	510	860	420	298
ATH 100-2/420				298

Coordinate system: X, Y, Z

## Optional



Automatic coupling foot  
Type: DUTY 100 and B6



Flanged hose connection N3  
Foot support P7



## Grinder submersible electropumps with cutting system

Power:	<b>0.9 ÷ 1.4 kW</b>
Delivery:	<b>G 1 1/4 DN32</b>



### Application

The Grix range of submersible pumps have an inbuilt macerator in the inlet. This breaks down solids in waste water which permits transport along relatively narrow, often pre-existing, pipes. Applications: domestic sewage, liquids with suspended solids, whenever high pressure (Hm) is needed.

### Characteristic

The main components are fabricated in cast iron GG20. The configuration has a lip seal fitted to the motor side, and a mechanical seal in oil chamber, on the impeller side.

### Motor range

- Squirrel cage motor in 2 poles version
- Thermal protection embedded in the winding
- Insulation class F 155°C
- Motor protection IP 68

### Designation

#### GRIX 32 - 2 / 110 M/T G

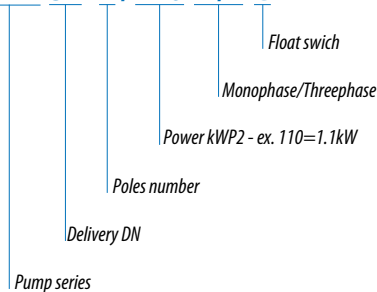

### Motor cooling

The cooling of the motor is ensured by the liquid where the pump is submerged.

### Limits of use

- Max. permissible liquid temperature: 40°C with pump fully submerged.
- Maximum depth of immersion: 20 mt.
- Permissible pH value: 6-10
- Hydraulic features suitable for liquids with density <math>< 1,1 \text{ kg/dm}^3</math>
- Allowed voltage: 230V/400V  $\pm 5\%$
- Allowed frequency: 50Hz  $\pm 2\%$

### Performance Overview

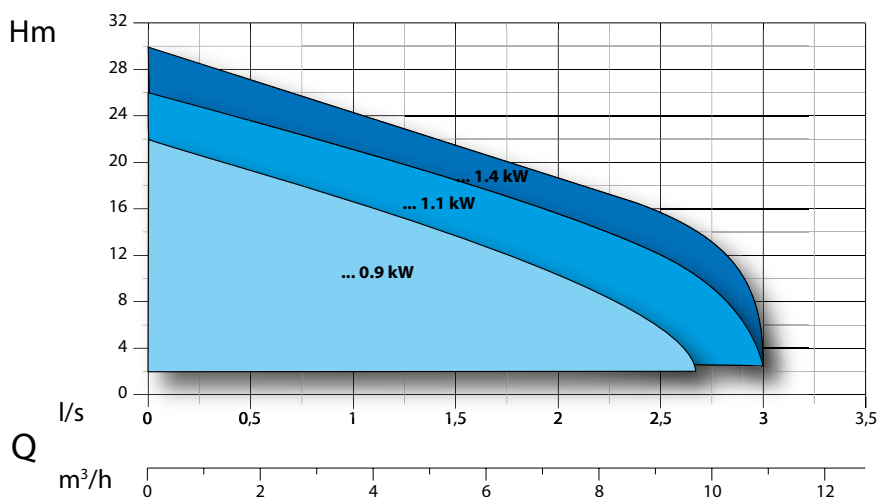

### Curves Identification

- DN32 - G 1 1/4
- DN32 - G 1 1/4
- DN32 - G 1 1/4

### Norms

According to ISO 9906:2012 3B2

## List of components and materials

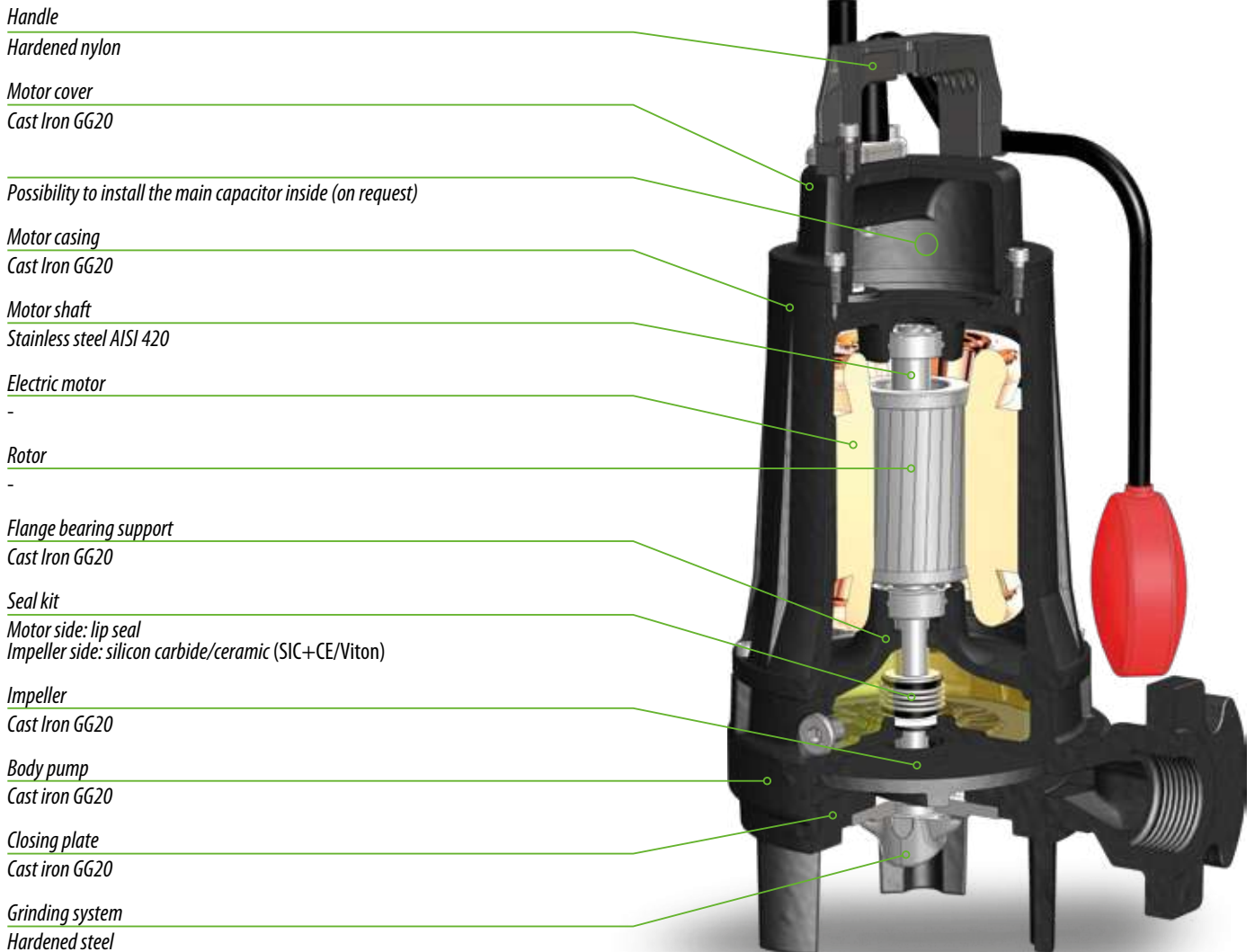

## Technology and Features



### Grinder system

The pump has a radial macerator in the inlet. The blades are made of hardened steel guaranteeing maximal cutting efficiency.



### Relay

For the correct operation of the float switch on the three-phase version.



Flanged outlet DN32 PN6 with inner thread G 1<sup>1</sup>/<sub>4</sub> (female)

Horizontal Outlet DN32 PN6 - G 1"1/4  
RPM 2850 1/min 2 poles



Picture for illustration purposes only

## Performance Curve

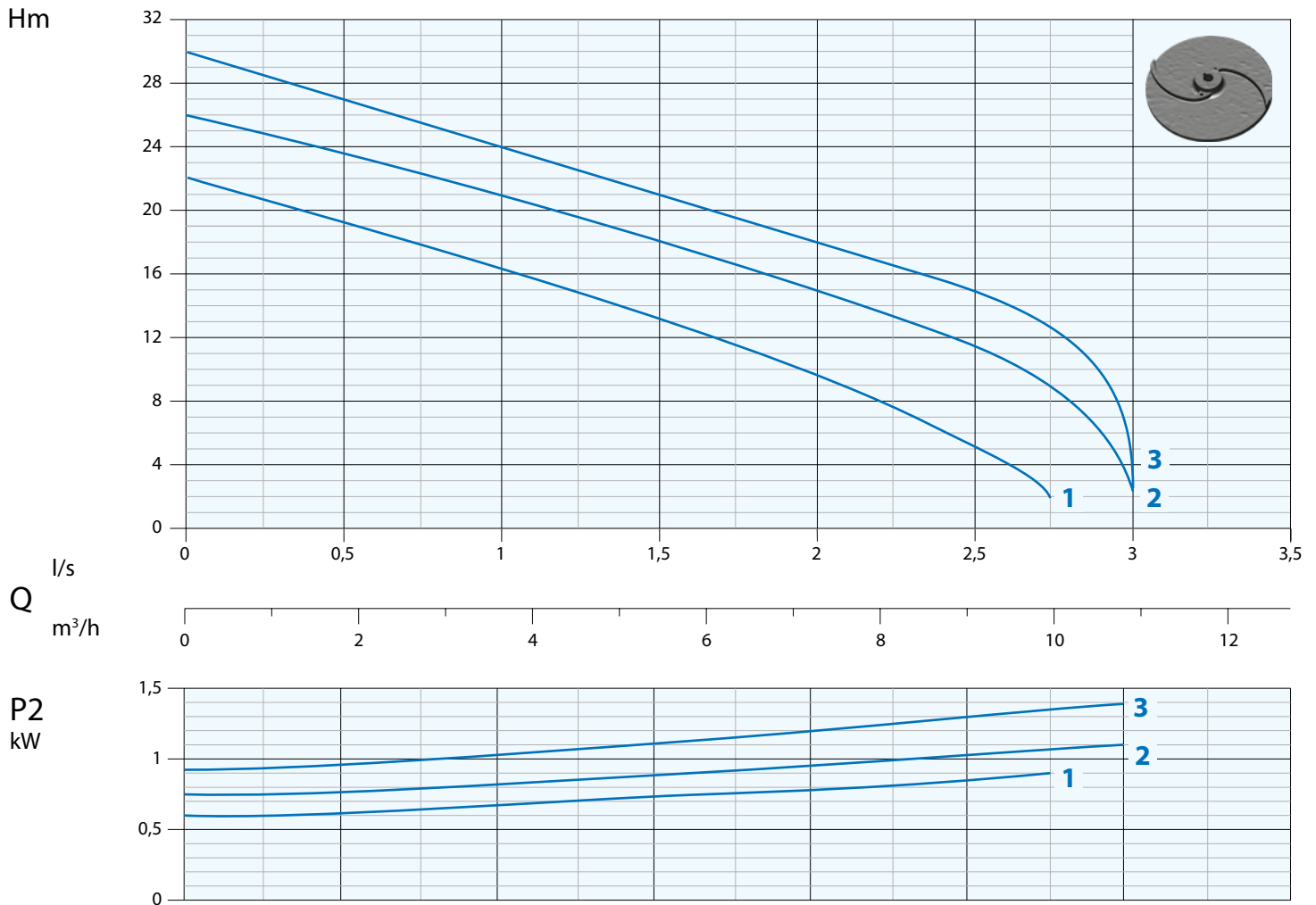

N°	Type		l/s	0,25	0,5	1	1,25	1,5	2	2,25	2,5	2,75	3
			l/m	15	30	60	75	90	120	135	150	165	180
		m³/h	0,9	1,8	3,6	4,5	5,4	7,2	8,1	9	9,9	10,8	
1	Grix 32-2/090 M/T		21	19	16,5	15	13	10	7,5	5	2		
2	Grix 32-2/110 M/T	mt	25	23,5	21	19,5	18	15	13,2	11,5	9	2	
3	Grix 32-2/140 M/T		28,5	27	24	22,5	21	18	16,5	15	12,5	2	

N°	Type	Delivery	Free Passage	kW		HP	R.P.M. 1/min	A		Hz
				P1	P2			1 Phase - 230V	3 Phase - 400V	
1	Grix 32-2/090 M/T	DN32 PN6 G 1"1/4	-	1,2	0,9	1,2	2850	5	25	2,1
2	Grix 32-2/110 M/T		-	1,5	1,1	1,5		7	30	2,9
3	Grix 32-2/140 M/T		-	1,7	1,4	1,9		9	35	3,5

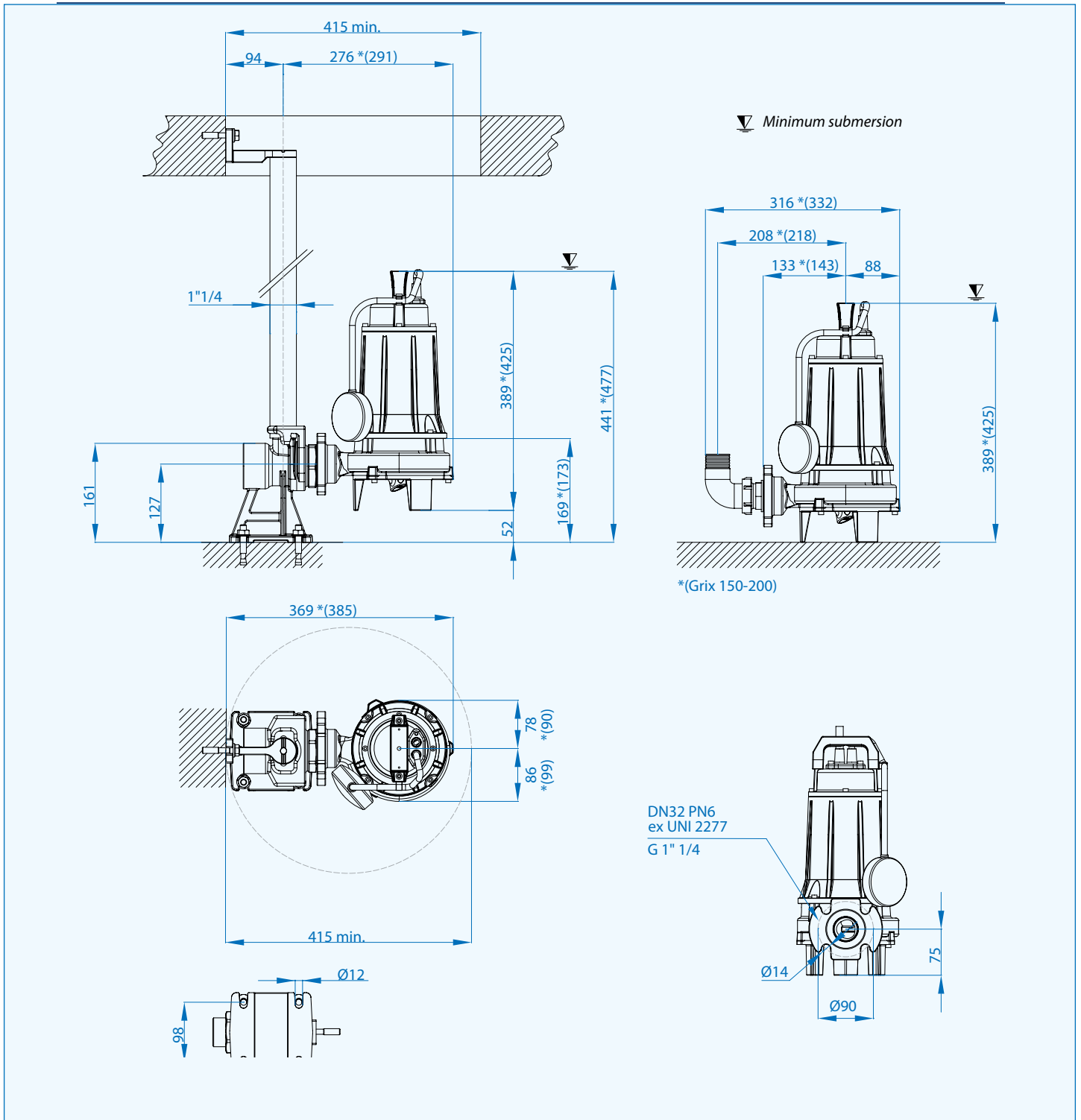

## Cables

Phases	Cable	Cable cross section mm <sup>2</sup>	mt
1 ~ 230V	H07RN8F	4x1 Ø10*	10
3 ~ 400V		4x1 Ø10**	10

\* Standard with Control Box (main and start capacitors included)

\*\* Free terminals

## Packaging dimension

Type	X mm	Y mm	Z mm	Kg
Grix 32-2/090 M/T				21,5
Grix 32-2/110 M/T	230	450	270	25
Grix 32-2/140 M/T				27,5

## Optional



Automatic coupling foot Type: Duty 50 and EASY E 1.1/1.2



Thread hose connection 1" 1/4

# Grinder submersible electropumps with cutting system

Power:	<b>0.9÷1.1 kW</b>
Delivery:	<b>G 2" Maschio - Male</b>



### Application

The G2 poles Series have an inbuilt macerator in the inlet. This breaks down solids in waste water which permits transport along relatively narrow, often pre-existing, pipes.  
Applications: domestic sewage, liquids with su-suspended solids, whenever high pressure (Hm) is needed.

### Characteristic

The main components are fabricated in cast iron GG20 In the standard configuration a lip seal in oil chamber, is fitted to the motor side, and a mechanical seal to the impeller side.

### Motor range

- Squirrel cage motor at 2 poles
- Thermal protection T1 and T2 embedded in the motor winding (to be wired to the three pole contactor in the control panel)
- Class F insulation (155°C)
- IP 68 protection

### Motor cooling

The cooling of the motor is ensured by the liquid where the pump is submerged.

### Limits of use

- Max. permissible liquid temperature: 40°C with pump fully submerged
- On request, special version (excluded ATEX) to withstand liquid temperature up to 60°C with pump fully submerged, no S1 service
- Maximum depth of immersion: 20 MT.
- Permissible pH value: 6-10
- Hydraulic features suitable for liquids with density <math>< 1,1 \text{ kg/dm}^3</math>
- Allowed voltage: 230V/400V  $\pm 5\%$
- Allowed frequency: 50Hz  $\pm 2\%$

### Designation

**GT-EX 50 / 2 / 110 C.149**

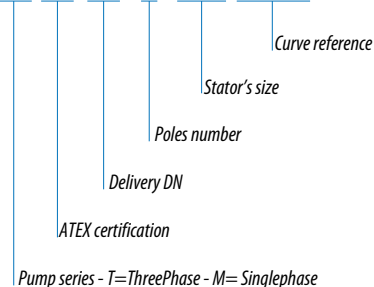

### Performance Overview

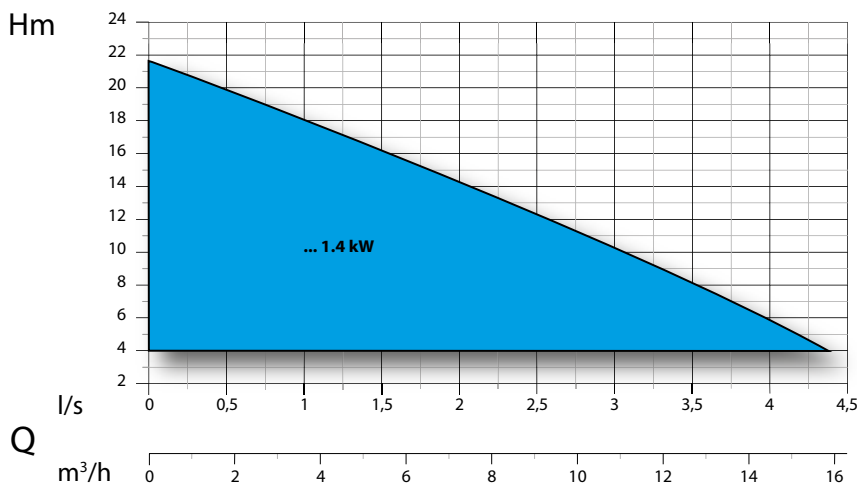

### Curves Identification

■ G 2" male

### Norms

According to ISO 9906:2012 3B2

**List of components and materials**

- Handle*  
Hardened nylon
- Motor casing*  
Cast Iron GG20
- Motor shaft* Stainless  
steel AISI 420
- Electric motor*  
-
- Rotor*  
-
- Bearing support flange*  
Cast Iron GG20
- Seal kit*  
Motor side: lip seal  
Impeller side: silicon carbide/ceramic (SiC+CE/Viton)
- Impeller*  
Cast Iron GG20
- Body pump*  
Cast iron GG20
- Closing plate*  
Cast iron GG20
- Grinding system*  
Hardened steel

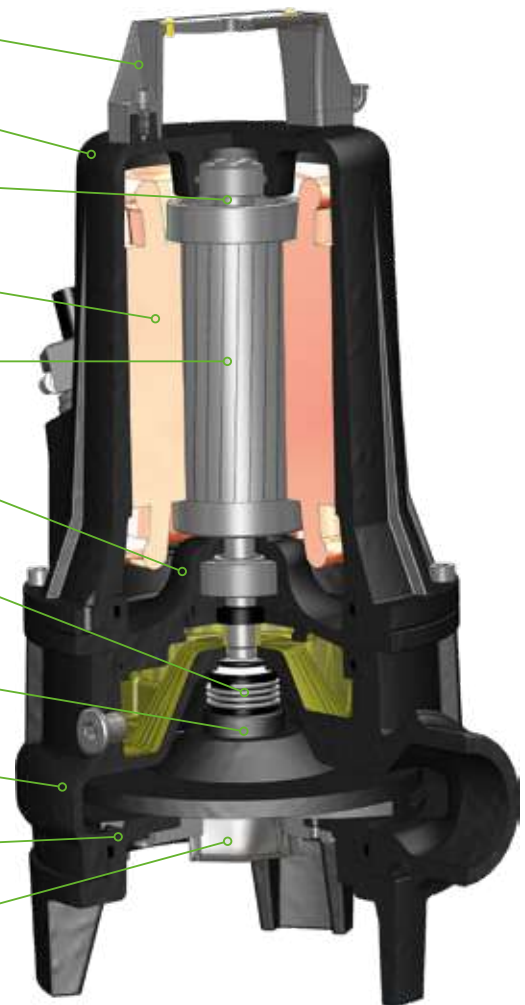

**Technology and Features**



**Grinding system**  
The pump has a macerator in the inlet with axial cutting action. The blades are made of hardened steel guaranteeing maximal cutting efficiency.



**Explosion proof pumps**  
Pumps with explosion proof available on request.

**CE** 0477  
EPT 17 ATEX 2701 X



Ex db IIB T4 Gb  
Ex h IIB T4 Gb  
0° Ta ~ 40°



**Cable gland**  
The cable gland is made of stainless steel AISI 316 and certified according to the norm ATEX EN 60079-0, EN 60079-1. Standard on all series.

### Horizontal Outlet DNG 2" - RPM 2850 1/min 2 poles

Picture for illustration purposes only



**L** maximum pump efficiency

### Performance Curve

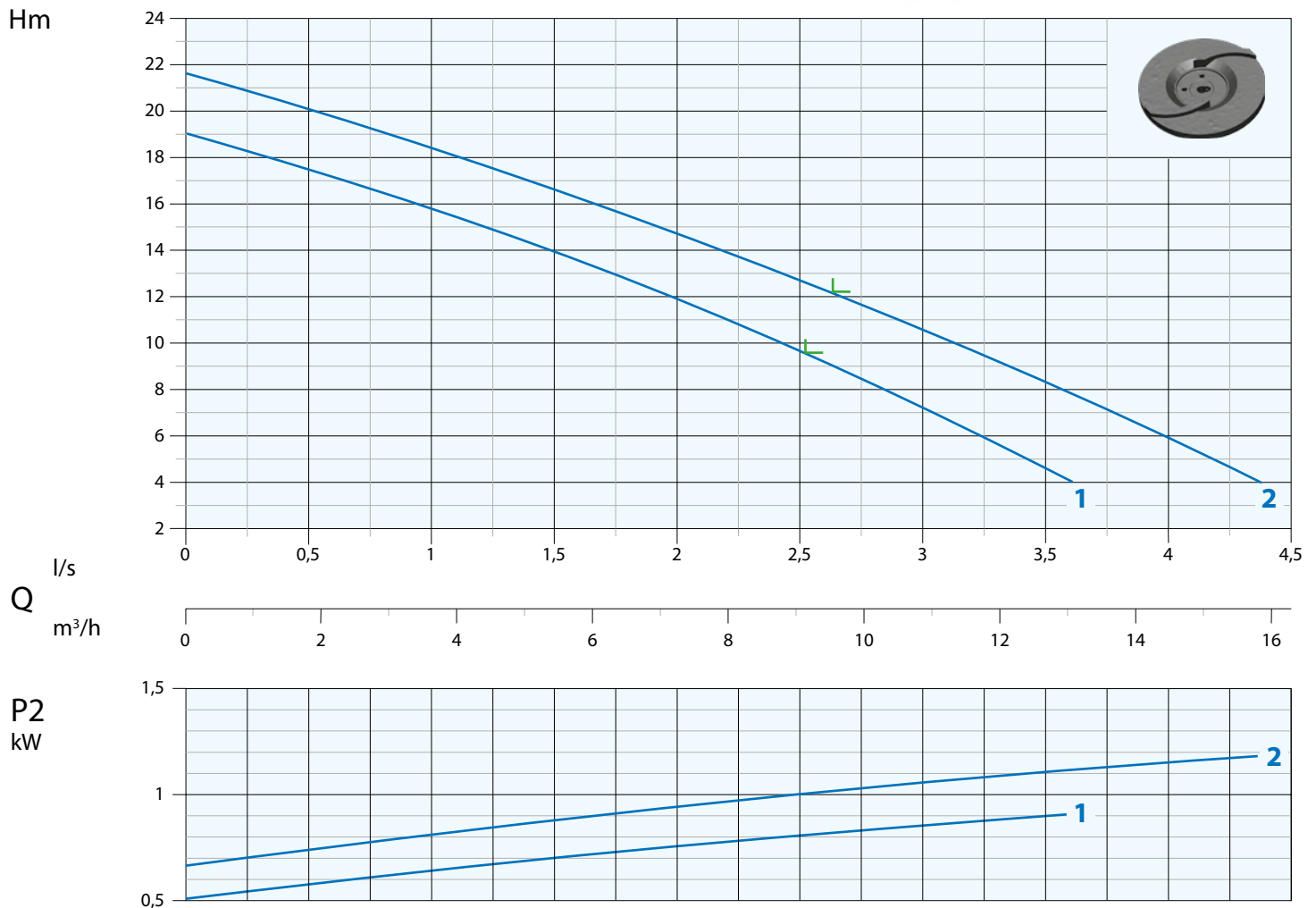

N°	Type	l/s	0,25	0,5	1	1,5	2	2,5	3	3,5	4	4,5
			l/m	15	30	60	90	120	150	180	210	240
		m³/h	0,9	1,8	3,6	5,4	7,2	9	10,8	12,6	14,4	16,2
1	GM-GT 50/2/110 C.149	mt	18,5	17,5	16	14	12	9,5	7	4,25		
2	GM-GT 50/2/110 C.150		21	20	18,5	16,5	14,5	12,5	10,5	8,5	6	4,5

N°	Type	EX	Delivery	Free Passage	kW		HP	R.P.M. 1/min	A		Hz
					P1	P2			1 Phase - 230V	µf	
1	GM-GT 50/2/110 C.149	•	G 2"	-	1,2	0,9	1,2	2850	5,5	25	2,3
2	GM-GT 50/2/110 C.150	•	(maschio / male)	-	1,5	1,1	1,5		8,0	30	3,1

• Available explosion proof pump with certifications:

CE 0477  
EPT 17 ATEX 2701 X

Ex II 2G Ex db IIB T4 Gb  
Ex h IIB T4 Gb  
0° Ta - 40°

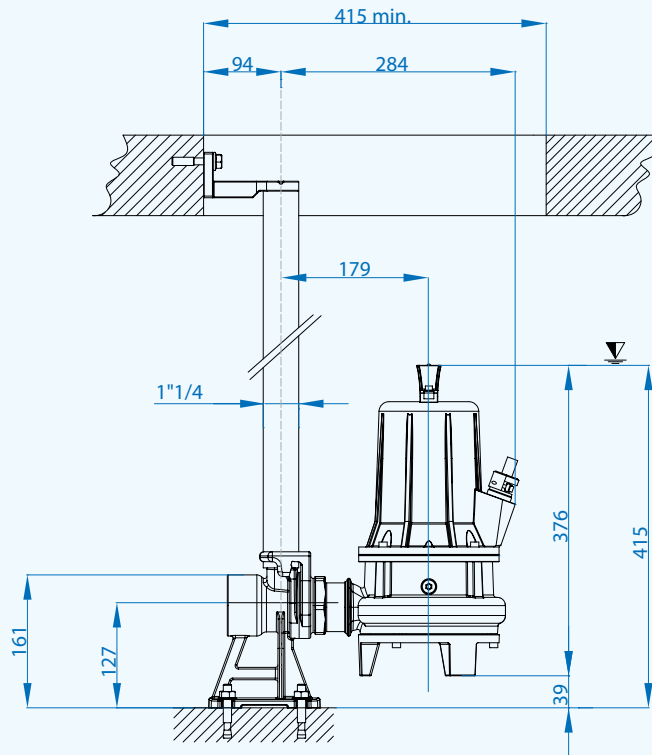

▽ Minimum submersion

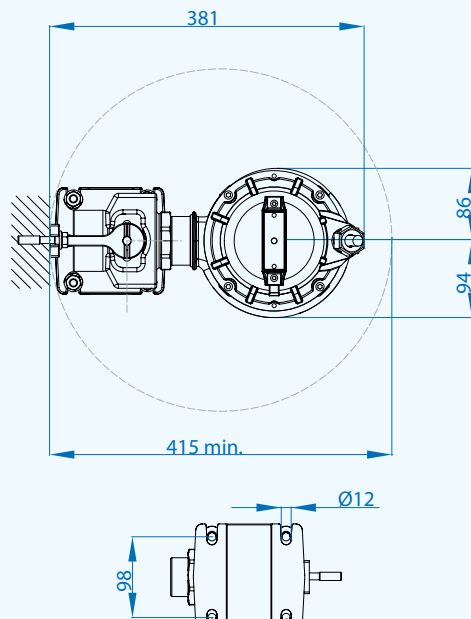
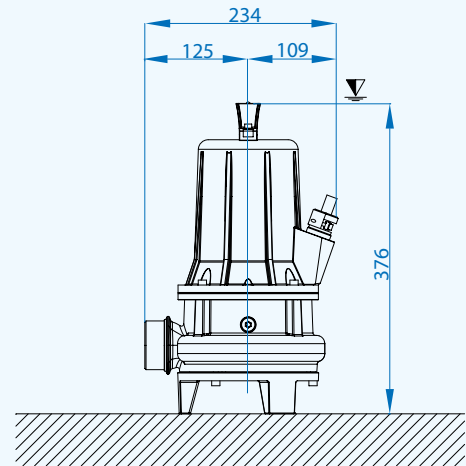

G 2" Maschio/Male

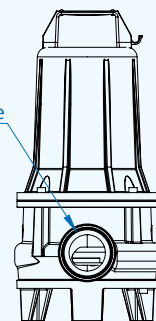

## Cables

Version	Phases	Cable	Cable cross section mm <sup>2</sup>	mt
Standard	1 ~ 230V	H07RN8F	4x1,5+2x0,5 Ø12*	10
	3 ~ 400V		4x1,5+2x0,5 Ø12**	10
ATEX	1 ~ 230V	NSSHÖU-J	4x1,5+2x0,5 Ø12*	10
	3 ~ 400V		4x1,5+2x0,5 Ø12**	10

\* Standard with Control Box

\*\* Free terminals

## Packaging dimension

Type	X mm	Y mm	Z mm	Kg
GM-GT 50/2/110 C.149	230	450	270	25
GM-GT 50/2/110 C.150				25



## Optional



Automatic coupling foot  
Type: EASY E4.1 or E4.2



Explosion proof control box available on request



## Submersible electropumps with Grinder system

Power	1.7÷9.5 kW
Delivery:	DN32 G 2"- DN50 G 2"



### Designation

**GT-EX 50 / 2 / 125 C.155**

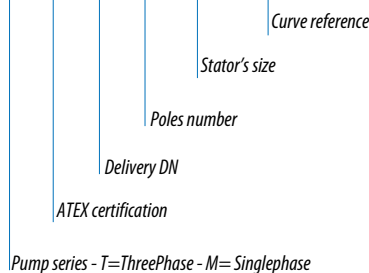

### Application

The G range has an inbuilt macerator in the inlet. This breaks down solids in waste water which permits transport along relatively narrow, often pre-existing, pipes.

Applications: domestic and industrial sewage, li-uids with suspended solids, whenever high pres-sure (head) is needed.

### Characteristic

All main components are made of grey cast iron GG25. Two individual mechanical seals (motor side in the oil chamber, impeller side in contact with the liquid) and high quality parts, ensure the perfect functioning and reliability of the product.

### Motor range

- Squirrel cage motor at 2 poles
- Thermal protection T1 and T2 embedded in the motor winding (to be wired to the three pole con-tactor in the control panel)
- Class F insulation (155°C)
- IP 68 protection

### Motor cooling

The cooling of the motor is ensured by the liquid where the pump is submerged.

### Limits of use

- Max. permissible liquid temperature: 40°C with pump fully submerged
- On request, special version (excluded ATEX) to withstand liquid temperature up to 60°C with pump fully submerged, no S1 service
- Maximum depth of immersion: 20 MT.
- Permissible pH value: 6-10
- Hydraulic features suitable for liquids with density <math>< 1,1 \text{ kg/dm}^3</math>
- Allowed voltage: 230V/400V-400V/690V  $\pm 5\%$
- Allowed frequency: 50Hz  $\pm 2\%$

### Performance Overview

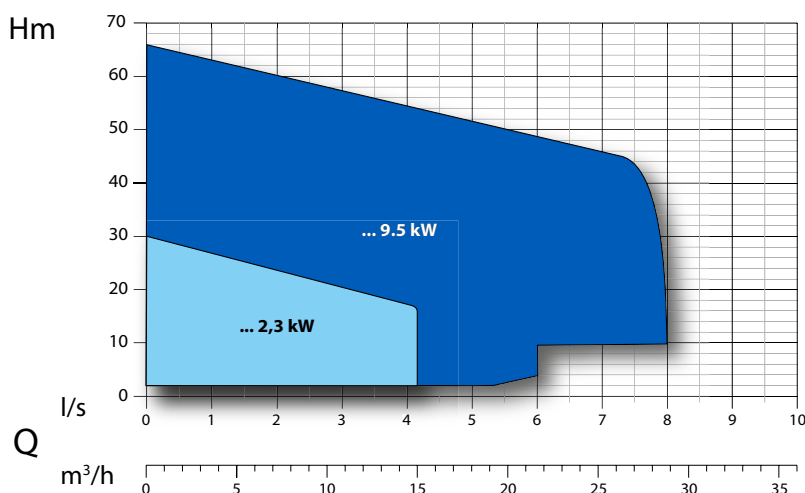

### Curves Identification

- DN32 - G 2" (50/2/125 C.155-160)
- DN50 - G 2"

### Norms

According to ISO 9906:2012 3B2

**List of components and materials**

*Motor casing*  
Cast Iron GG20

*Motor shaft* Stainless  
steel AISI 420

*Electric motor*  
-

*Rotor*  
-

*Flange bearing support*  
Cast Iron GG20

*Mechanical seal*  
Carbon/Ceramic (CA/CE/Viton)

*Mechanical seal*  
Silicon/Carbide (SIC/SIC/Viton)

*Impeller*  
Cast Iron GG20

*Body pump*  
Cast iron GG20

*Closing plate*  
Cast iron GG20

*Grinding system*  
Hardened steel

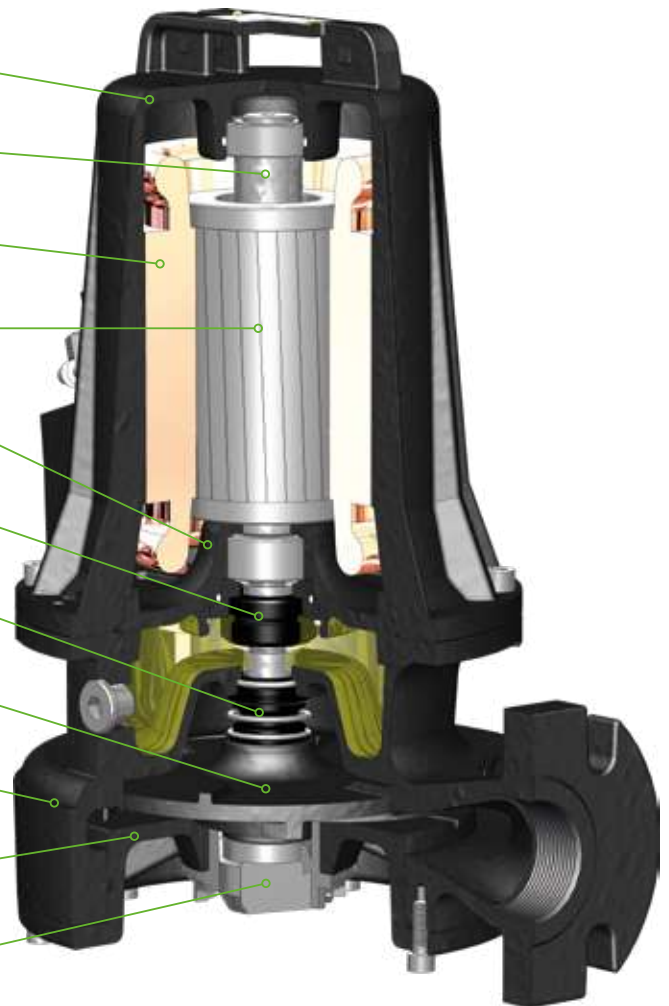

**Technology and Features**



**Grinding system**

The pump has a macerator in the inlet with radial and axial cutting action. The blades are made of hardened steel guaranteeing maximal cutting efficiency.



**Explosion proof pumps**



EPT 17 ATEX 2702 X



Ex db IIB T4 Gb  
Ex h IIB T4 Gb  
0° ~ Ta ~ 40°

Pumps with explosion proof available on request.



**Seal leak detector**

The seal leak detector is certified according to the norm ATEX EN 60079-0, EN 60079-1 (through safety barrier) and fitted standard on all series.



**Cable gland**

The cable gland is made of stainless steel AISI 316 and certified according to the norm ATEX EN 60079-0, EN 60079-1. Standard on all series.

## Horizontal Outlet DN32 and DN50 - G 2" - RPM 2850 1/min 2 poles

Picture for illustration purposes only



### Performance Curve

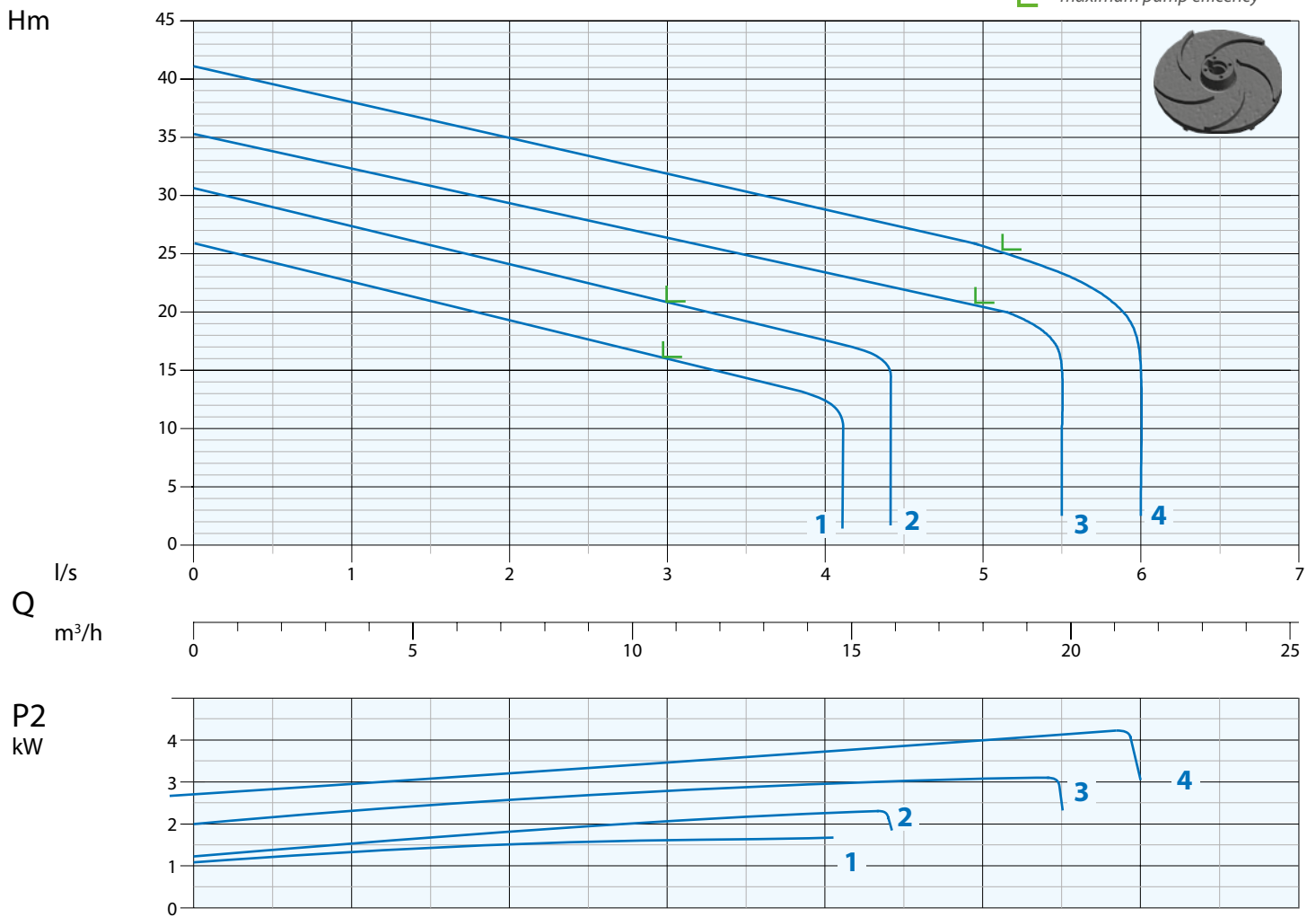

N°	Type	l/s	0,5	1	1,5	2	2,5	3	3,5	4	5	6
			l/m	30	60	90	120	150	180	210	240	300
		m³/h	1,8	3,6	5,4	7,2	9	10,8	12,6	14,4	18	21,6
1	GM-GT 50/2/125 C.155	mt	24	22,5	21	19	17,5	16	14	12		
2	GM-GT 50/2/125 C.160		29	27	26	24	22,5	21	19	17,5		
3	GT 50/2/152 C.165		34	32	31	29	28	26	25	23	20,5	
4	GT 50/2/152 C.170		39,5	38	36,5	35	33	32	30	29	26	3

N°	Type	EX	Delivery	Free Passage	kW			R.P.M. 1/min	A		Hz
					P1	P2	HP		1 Phase - 230V	3 Phase - 400V	
1	GM-GT 50/2/125 C.155	•	DN32 PN6 - G 2"	-	2,4	1,6	2,5	2850	11	35	3,7
2	GM-GT 50/2/125 C.160	•		-	2,9	2,3	3		13,2	50	5,2
3	GT 50/2/152 C.165	•	DN50 PN10 - G 2"	-	4,0	3,2	4,5		6,9	50	
4	GT 50/2/152 C.170	•		-	5,2	4,2	6		8,9		

• Available explosion proof pump with certifications:



EPT 17 ATEX 2702 X



II 2G Ex db IIB T4 Gb  
Ex h IIB T4 Gb  
0° Ta 40°

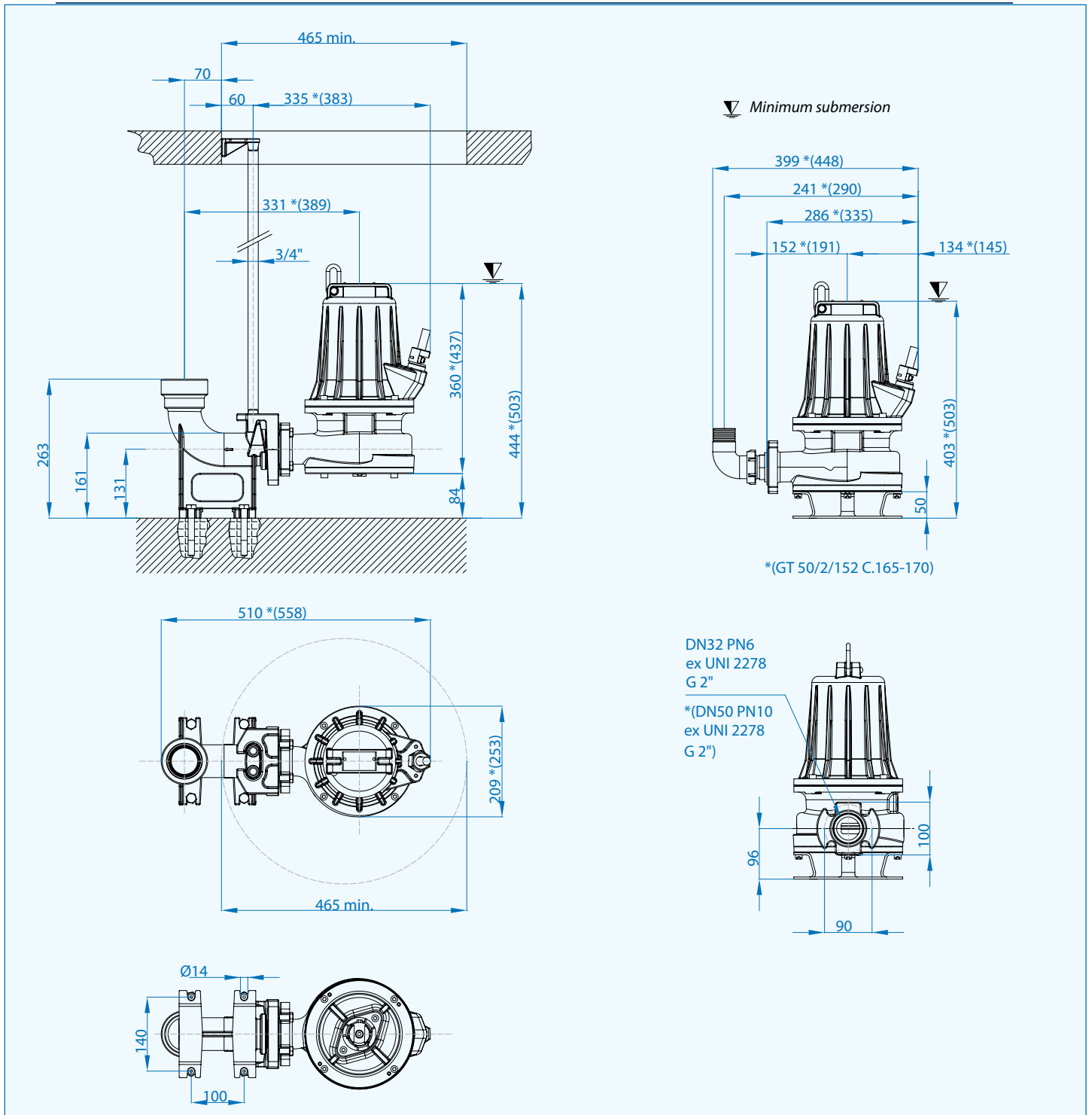

## Cables

Pumps	Version	Phases	Cable	Cable cross section mm <sup>2</sup>	mt
50/2/125	Standard	1 ~ 230V	H07RN8F	4x1,5+3x0,50 Ø15*	10
	ATEX	D.O.L.	NSSHÖU-J	4x1,5+3x0,50 Ø17*	10
50/2/125	Standard	3 ~ 400V	H07RN8F	4x1,5+3x0,50 Ø15**	10
	ATEX	D.O.L.	NSSHÖU-J	4x1,5+3x0,50 Ø17**	10
50/2/152	Standard	3 ~ 400V	H07RN8F	4x1,5+3x0,50 Ø15**	10
	ATEX	D.O.L.	NSSHÖU-J	7x1,5+3x0,50 Ø17**	10

\* Standard with Control Box (main and start capacitors included)

\*\* Free terminals

## Packaging dimension

Type	X mm	Y mm	Z mm	Kg
GM-GT 50/2/125 C.155	295	460	330	39,5
GM-GT 50/2/125 C.160				40,5
GT 50/2/152 C.165				63
GT 50/2/152 C.170	355	580	420	66

## Optional



Automatic coupling foot  
Type: DUTY 50 and B4/PN6  
(only C.165-170)



50/2/125 Thread hose connection G2"  
Foot support P1  
50/2/152 Flanged curve N1  
Foot support P2



Stainless steel handle

### Horizontal Outlet - DN50 PN10 G 2" - RPM 2850 1/min 2 poles

Picture for illustration purposes only



### Performance Curve

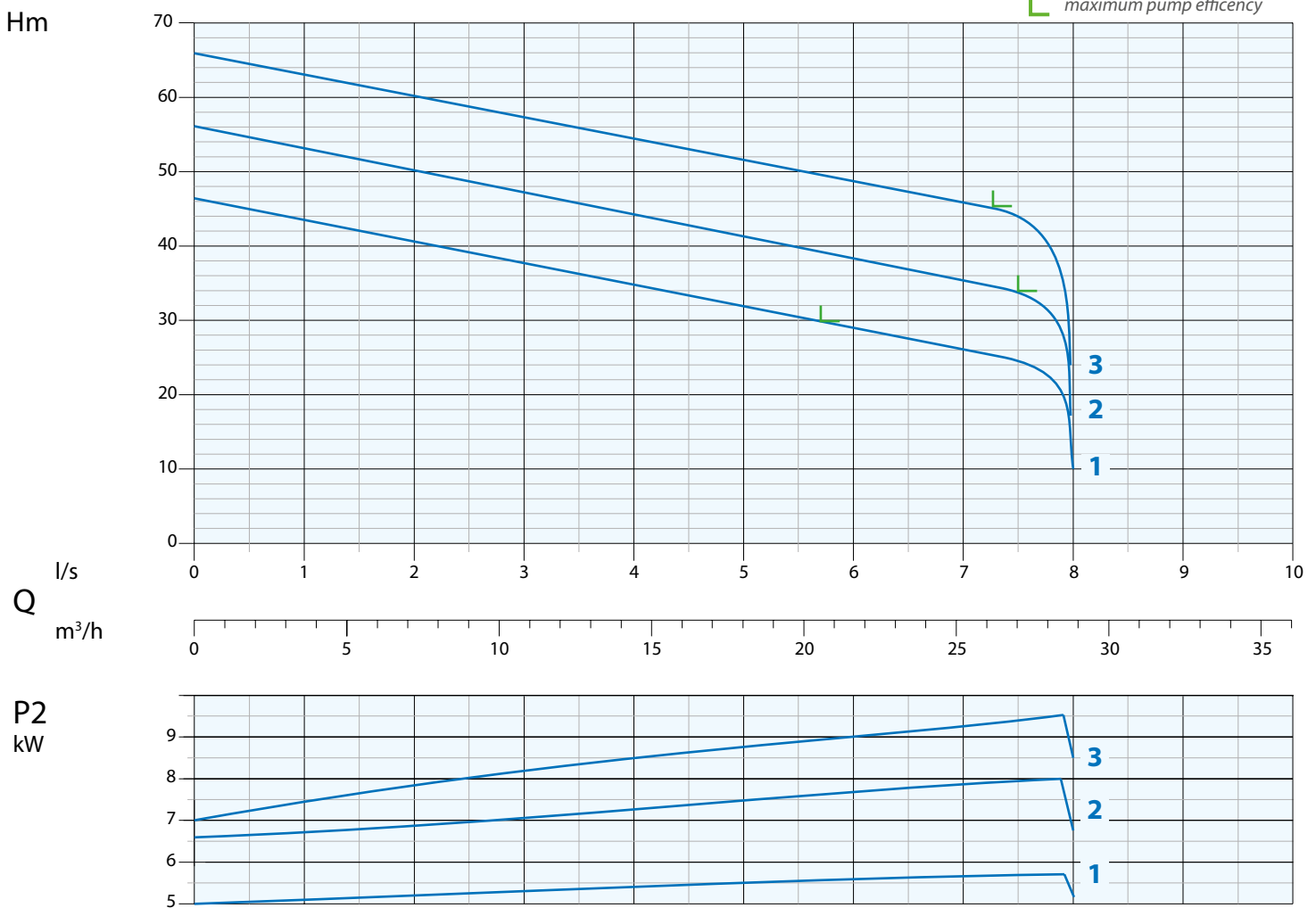

N°	Type		l/s	0,5	1	2	3	4	5	6	7	7,5	8
			l/m	30	60	120	180	240	300	360	420	450	480
			m <sup>3</sup> /h	1,8	3,6	7,2	10,8	14,4	18	21,6	25,2	27	28,8
1	GT 50/2/173 C.175	mt		42,5	43	41	37,5	35	32	28	26	25	10
2	GT 50/2/173 C.180		52	52,5	50	47,5	45	41	38	35	34	20	
3	GT 50/2/173 C.185		62	62,5	60	57,5	55	52	48	46	44	30	

N°	Type	EX	Delivery	Free Passage	kW			R.P.M. 1/min	A 3 Phase - 400V	Hz
					P1	P2	HP			
1	GT 50/2/173 C.175	•	DN50 PN10 - G 2"	-	7,6	6,2	8,5	2850	12,4	50
2	GT 50/2/173 C.180	•		9,6	7,8	10,5	16,2			
3	GT 50/2/173 C.185	•		11,5	9,5	13	20			

• Available explosion proof pump with certifications:



Ex db IIB T4 Gb  
Ex h IIB T4 Gb  
0° Ta ~ 40°

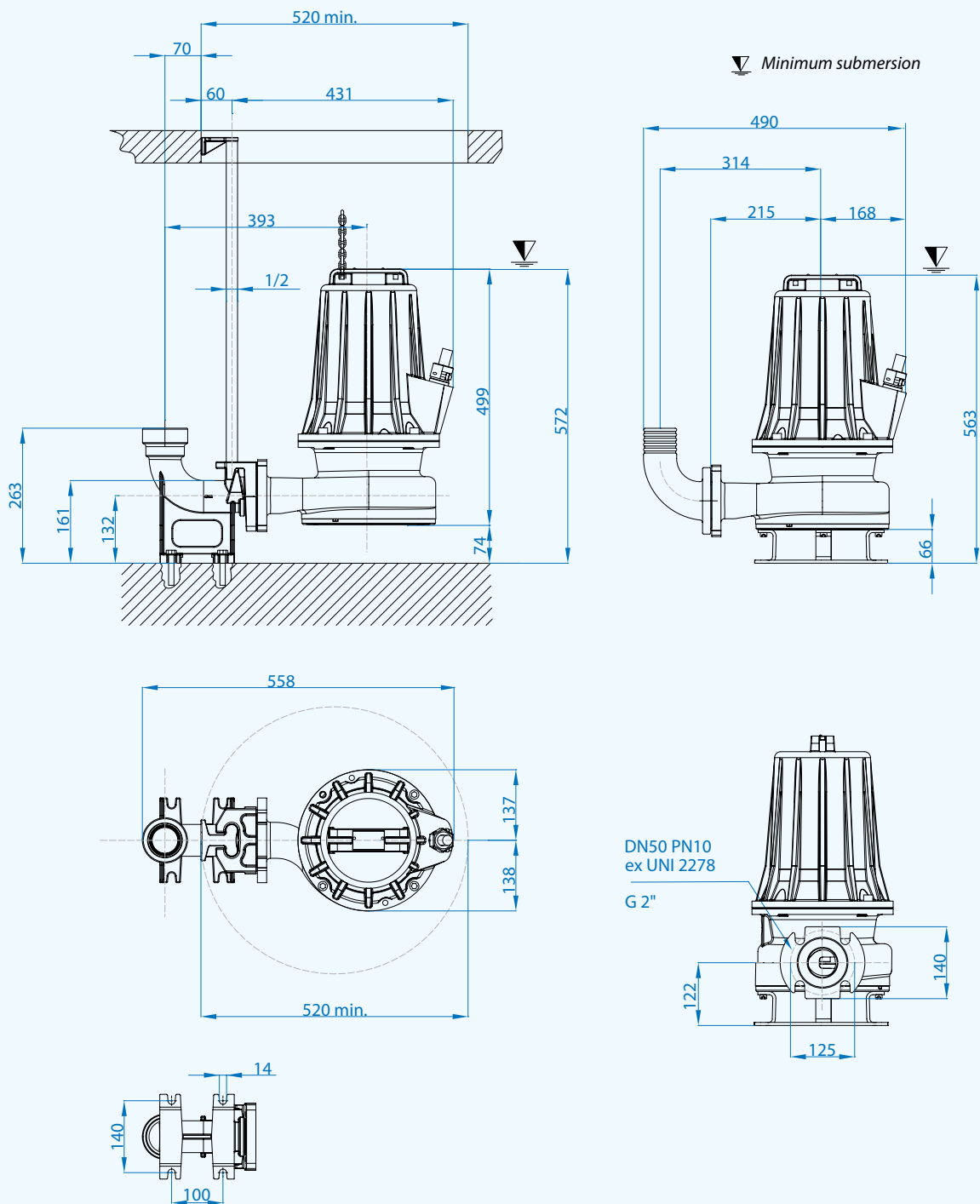

## Cables

Version	Phases	Cable	Cable cross section mm <sup>2</sup>	mt
Standard	3 ~ 400V	H07RN8F	7x1,5+3x0,50 Ø17*	10
ATEX	Y-Δ	NSSHÖU-J	7x1,5+3x0,50 Ø17*	10

\* Free terminals

## Packaging dimension

Type	X mm	Y mm	Z mm	Kg
GT 50/2/173 C.175				94
GT 50/2/173 C.180	355	580	420	95
GT 50/2/173 C.185				96

Y  
Z  
X

## Optional



Automatic coupling foot  
Type: DUTY 50 and B4



Flanged hose connection N1 Foot  
support P3



Stainless steel handle

## Submersible electropumps with twin channel impeller

Power:	<b>0.28 ÷ 1.5 kW</b>
Delivery	<b>G 1"¼ - G 1"½ - G 2"</b>



### Application

The BIC series is used to pump clear water or light sewage. High hydraulic performance renders this series particularly suited to pumping rainwater, sur-face water, groundwater, lakes and rivers.

### Characteristic

The main components are fabricated in cast iron GG20. In the standard configuration a lip seal is fit-ted to the motor side, and a mechanical seal to the impeller side. Also available on request in the new "EVO" version with Double Mechanical seal back to back, located in the oil chamber.

### Motor range

- Squirrel cage motor in 2 poles version
- Thermal protection embedded in the winding
- Only for BIC PRO and AM-AT 50/2/110, thermal protection T1 and T2 embedded in the motor winding (to be wired to the three pole contactor in the control panel)
- Insulation class F 155°
- Motor protection IP 68

### Motor cooling

The cooling of the motor is ensured by the liquid where the pump is submerged

### Limits of use

- Max. permissible liquid temperature: 40°C with pump fully submerged
- On request, special version (excluded ATEX) for BIC PRO and AM-AT 50/2/110 to withstand liquid temperature up to 60°C with pump fully submerged, no S1 service
- Maximum depth of immersion: 20 mt.
- Permissible pH value: 6-10
- Hydraulic features suitable for liquids with density <math>< 1,1 \text{ kg/dm}^3</math>
- Allowed voltage: 230V/400V  $\pm 5\%$
- Allowed frequency: 50Hz  $\pm 2\%$

### Designation

**BIC EVO EX 50 - 2 / 150**

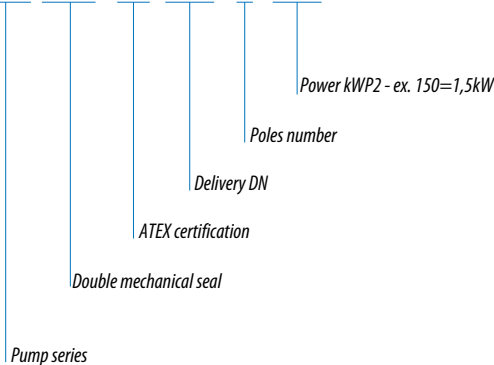

### Performance Overview

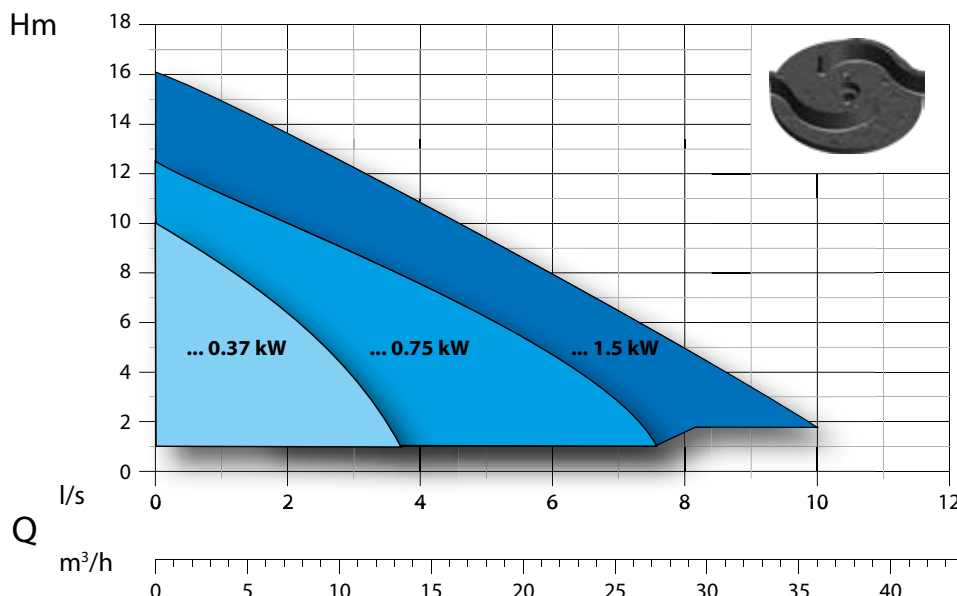

### Curves Identification

- G 1"¼
- G 1"½
- G 2"

### Norms

According to ISO 9906:2012 3B2

## List of components and materials

Handle  
Hardened nylon

Motor cover  
Cast Iron GG20

Motor casing  
Cast Iron GG20

Motor shaft  
Stainless steel AISI 420

Electric motor  
-

Rotor  
-

Flange bearing support  
Cast Iron GG20

Seal kit  
Motor side: lip seal  
Impeller side: silicon carbide/ceramic (SiC+CE/Viton)

Impeller  
Cast Iron GG20

Body pump  
Cast iron GG20

Strainer  
Stainless steel AISI 304

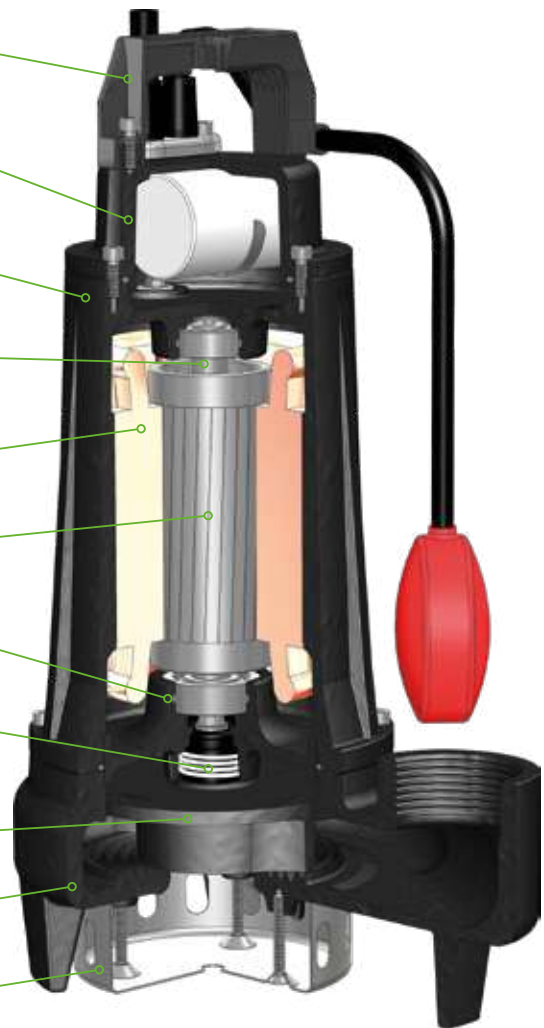

## Technology and Features



### EVO Version

With double Mechanical Seal in oil chamber  
Motor side: Carbon/Ceramic (CA/CE/Viton)  
Impeller side: Silicon carbide (SiC/SiC/Viton)  
Inspectional oil chamber



### Explosion proof pumps

The BIC PRO and A 50/2/110 C.225-226 series with explosion proof available on request.

CE 0477  
EPT 17 ATEX 2701 X

Ex II 2G Ex db IIB T4 Gb  
Ex h IIB T4 Gb 0° ~ Ta ~ 40°



### Relay

For the correct operating of the float switch on the three-phase version (only up to 1,5kW).



### Impellers

Twin channel impeller with strainer. Free passage up to 20x10 mm



## Vertical Outlet 1"1/4 - RPM 2850 1/min 2 poles

Picture for illustration purposes only



### Performance Curve

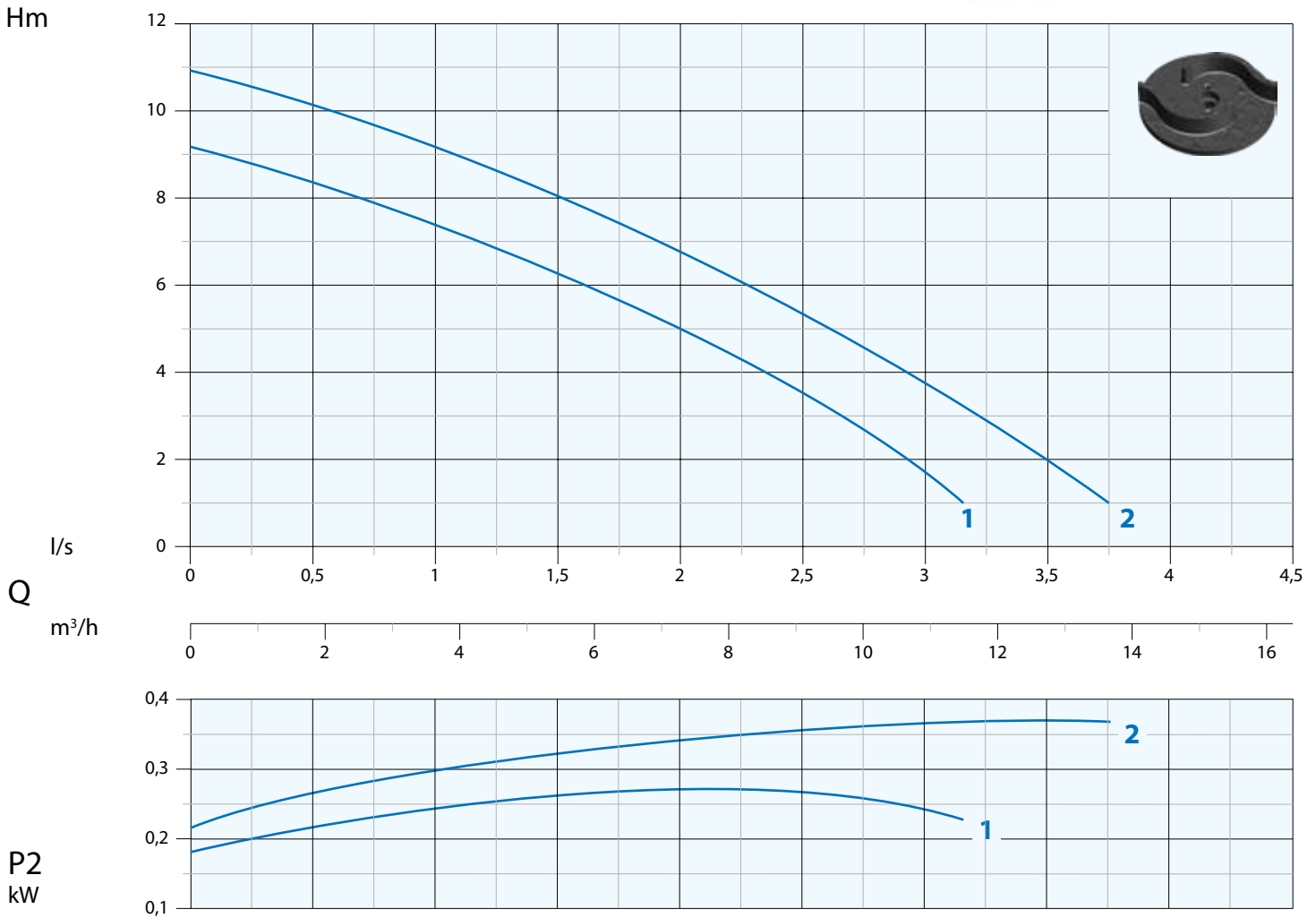

N°	Type		l/s	0,25	0,5	0,75	1	1,5	2	2,5	3	3,5
			l/m	15	30	45	60	90	120	150	180	210
		m³/h	0,9	1,8	2,7	3,6	5,4	7,2	9	10,8	12,6	
1	BIC 32-2/028 M	mt	8,8	8,5	7,8	7,5	6,5	5	3,5	1,8		
2	BIC 32-2/037 M/T		10,5	10,2	9,5	9	8	6,8	5,5	3,8	2	

N°	Type	Delivery	Free Passage	kW		HP	R.P.M. 1/min	A		Hz
				P1	P2			1 Phase - 230V	3 Phase - 400V	
1	BIC 32-2/028 M	G1"1/4	8x10 mm	0,40	0,28	0,4	2850	1,9	7,5	50
2	BIC 32-2/037 M/T			0,52	0,37	0,5		3,5	10	

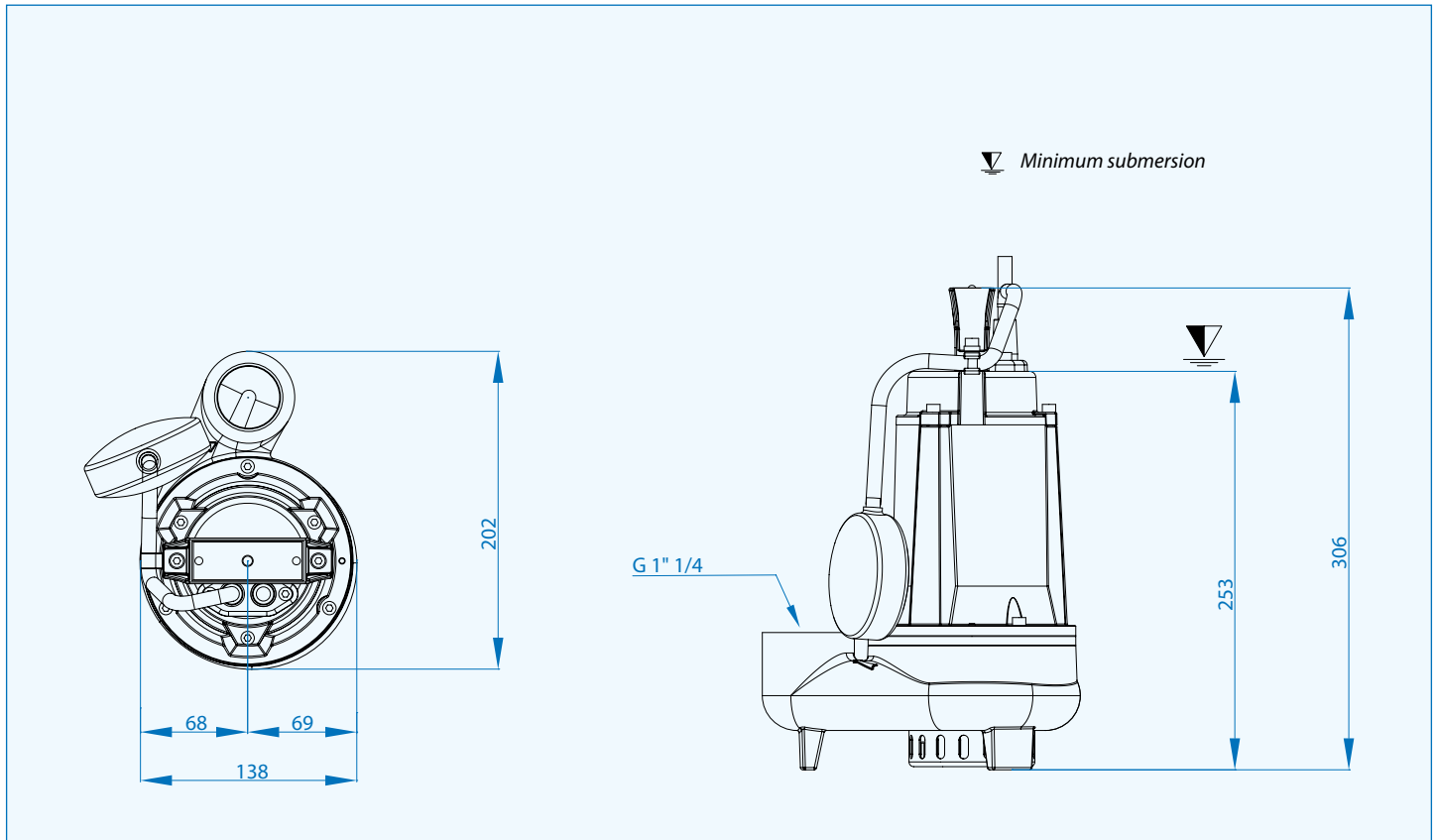

### Cables

Single phase 230V

H07RN8F 3x1 Ø9 Schuko plug - Length 10 mt

Threephase 400V

H07RN8F 4x1 Ø10 - Free terminals - Length 10 mt

### Optional



Hose connection 1" / 4



For single phase pumps: Control-box with external main capacitor

### Packaging dimension

Type	X mm	Y mm	Z mm	Kg
BIC 32-2/028 M	160	330	210	11
BIC 32-2/037 M/T				11,5



## Vertical Outlet - RPM 2850 1/min 2 poles

Picture for illustration purposes only



### Performance Curve

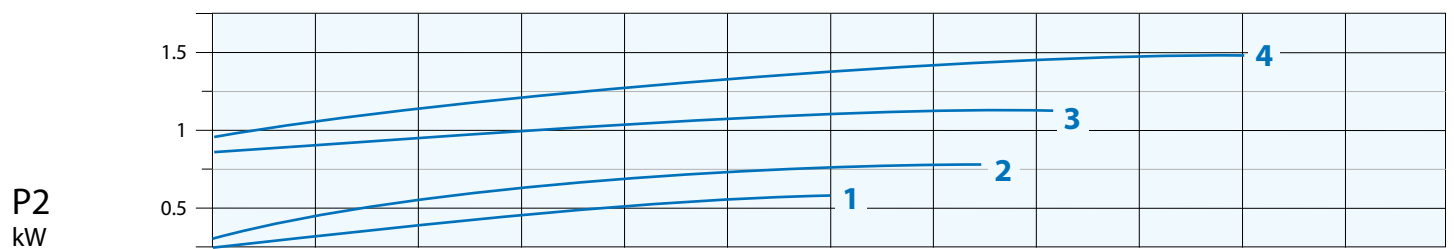
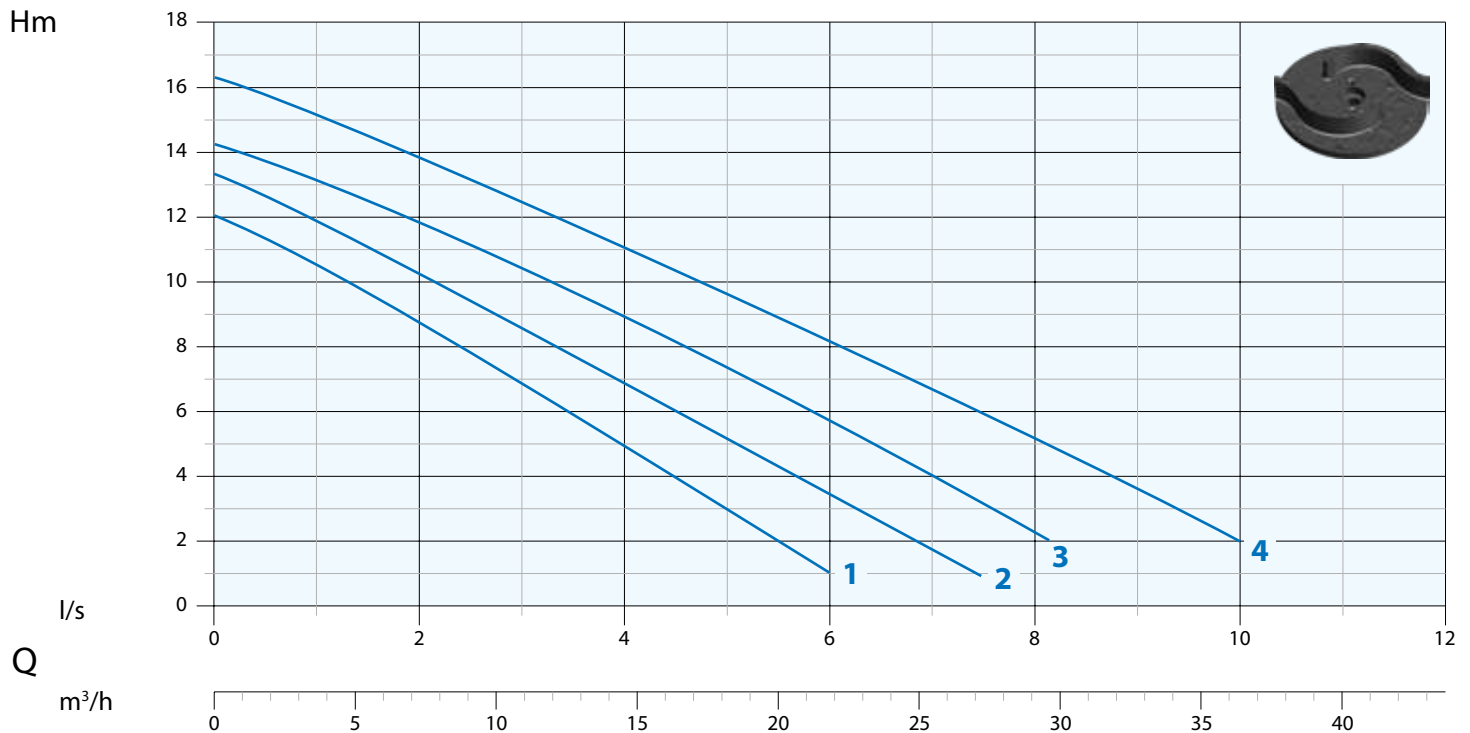

N°	Tipo Type	Flow (Q)																		
		1	2	3	4	5	6	7	8	9	10									
		l/s	l/m	m³/h	l/s	l/m	m³/h	l/s	l/m	m³/h	l/s	l/m	m³/h							
1	BIC 40-2/056 M/T	10,5	60	3,6	8,8	120	7,2	7	180	10,8	5	300	3	1	360	25,2	480	28,8	32,4	36
2	BIC 40-2/075 M/T	12	60	3,6	10,2	120	8,5	7	180	10,5	5	300	3,5	1,5	360	25,2	480	28,8	32,4	36
3	BIC 50-2/110 M/T	13	60	3,6	12	120	9	7,5	180	11	9,5	8	6,5	5	360	25,2	480	28,8	32,4	36
4	BIC 50-2/150 M/T	15	60	3,6	14	120	12,5	11	180	14,4	9,5	8	6,5	5	360	25,2	480	28,8	32,4	36

N°	Type	EVO	Delivery	Free Passage	kW			R.P.M. 1/min	A		
					P1	P2	HP		1 Phase - 230V	µf	3 Phase - 400V
1	BIC 40-2/056 M/T	•	G1 1/2"	20x10 mm	0,8	0,56	0,75	2850	3,8	16	1,6
2	BIC 40-2/075 M/T	•			0,9	0,75	1		4,6	20	2,0
3	BIC 50-2/110 M/T	•			1,2	1,1	1,5		6,2	30	2,5
4	BIC 50-2/150 M/T	•			1,9	1,5	2		9,9	32	3,6

• Available EVO version

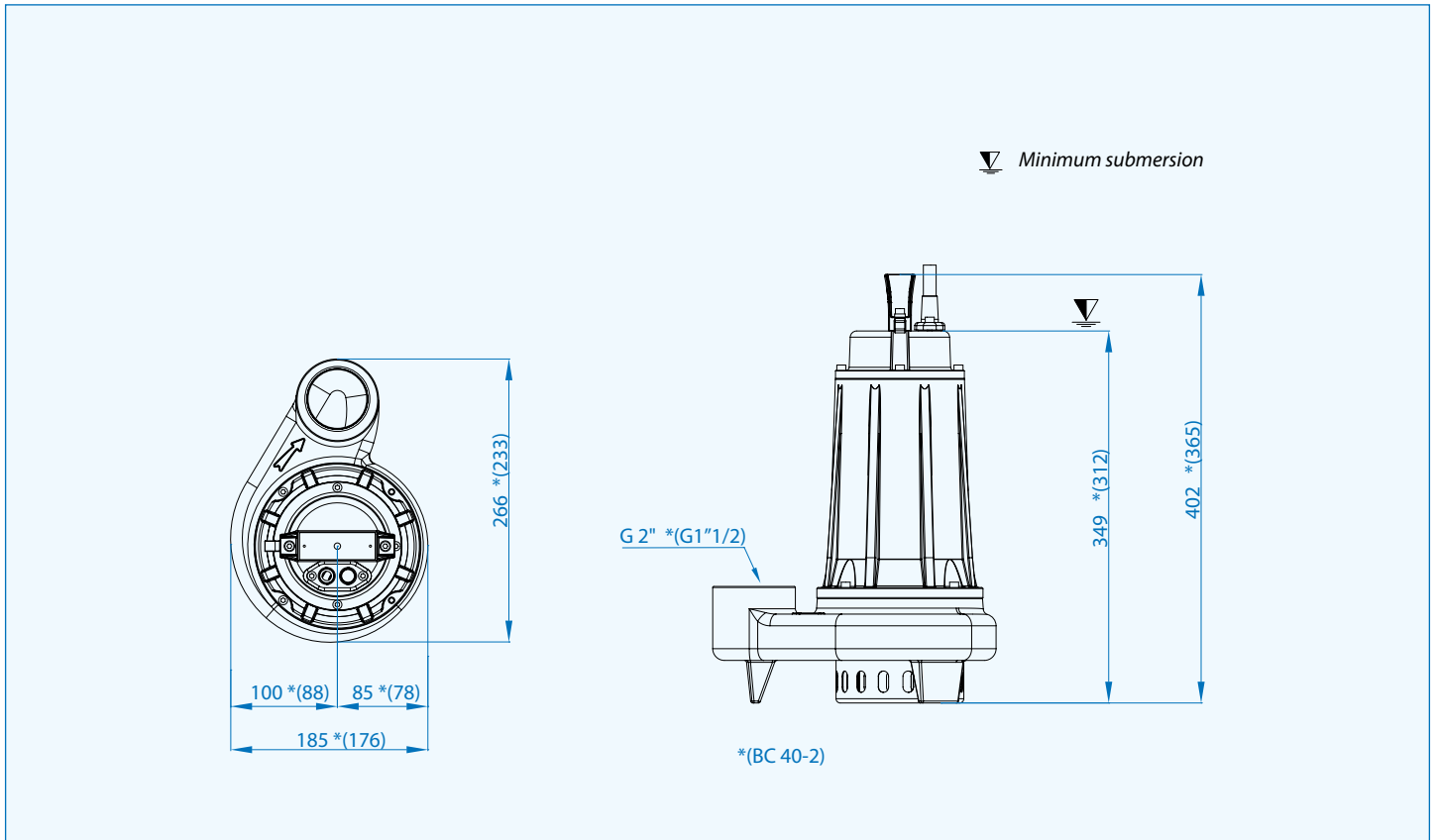

### Cables

Single phase 230V

H07RN8F 3x1 Ø9 - Schuko plug - Length 10 mt

Threephase 400V

H07RN8F 4x1 Ø10 - Free terminals - Length 10 mt

### Optional



Hose connection 1"1/2 BC 40 / 2" BC 50



For single phase pumps: Control-box with external main capacitor

### Packaging dimension

Type	X mm	Y mm	Z mm	Kg
BIC 40-2/056 M/T	200	380	230	17,5
BIC 40-2/075 M/T				18,5
BIC 40-2/110 M/T	230	450	270	21
BIC 40-2/150 M/T				22,5



### Vertical Outlet - RPM 2850 1/min 2 poles

Picture for illustration purposes only



### Performance Curve

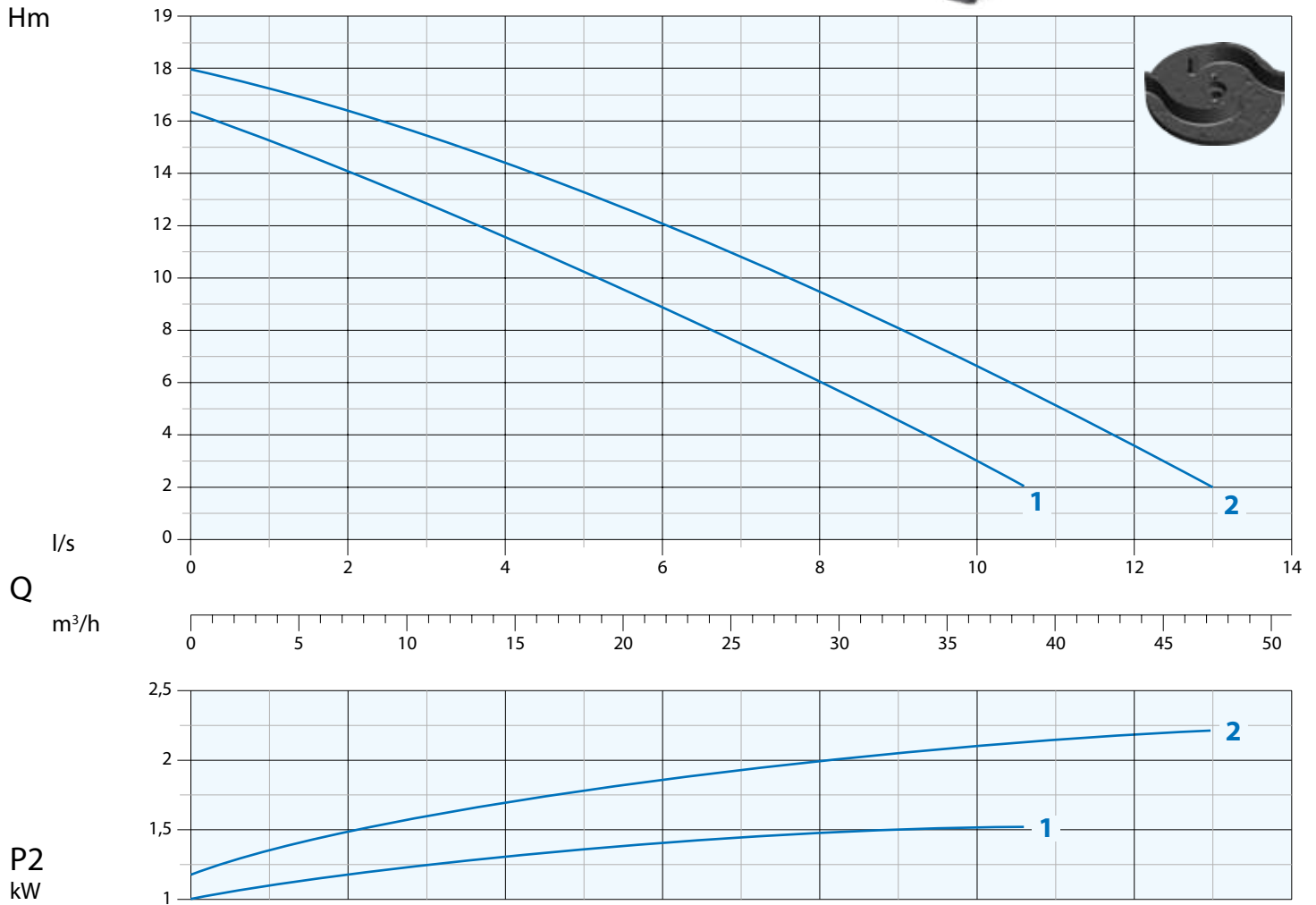

N°	Type	l/s	1	2	3	4	6	8	10	11	12	13
			l/m	60	120	180	240	360	480	600	660	720
		m³/h	3,6	7,2	10,8	14,4	21,6	28,8	36	39,6	43,2	46,8
1	BIC PRO 50-2/150 M/T	mt	15	14	13	11,5	9	6	3			
2	BIC PRO 50-2/220 T		17	16,5	15,5	14,5	12	9,5	6,5	5	3,5	2

N°	Type	EX	Delivery	Free Passage	kW		HP	R.P.M. 1/min	A		
					P1	P2			1 Phase - 230V	3 Phase - 400V	
1	BIC PRO 50-2/150 M/T	•	G2"	20x10 mm	2,0	1,5	2	2850	8,8	40	3,7
2	BIC PRO 50-2/220 T	•			2,7	2,2	3				5,2

BC-EX PRO 50-2/150 available only in Singlephase version

• Available explosion proof pump with certifications:



EPT 17 ATEX 2701 X



Ex db IIB T4 Gb  
Ex h IIB T4 Gb  
0° Ta 40°

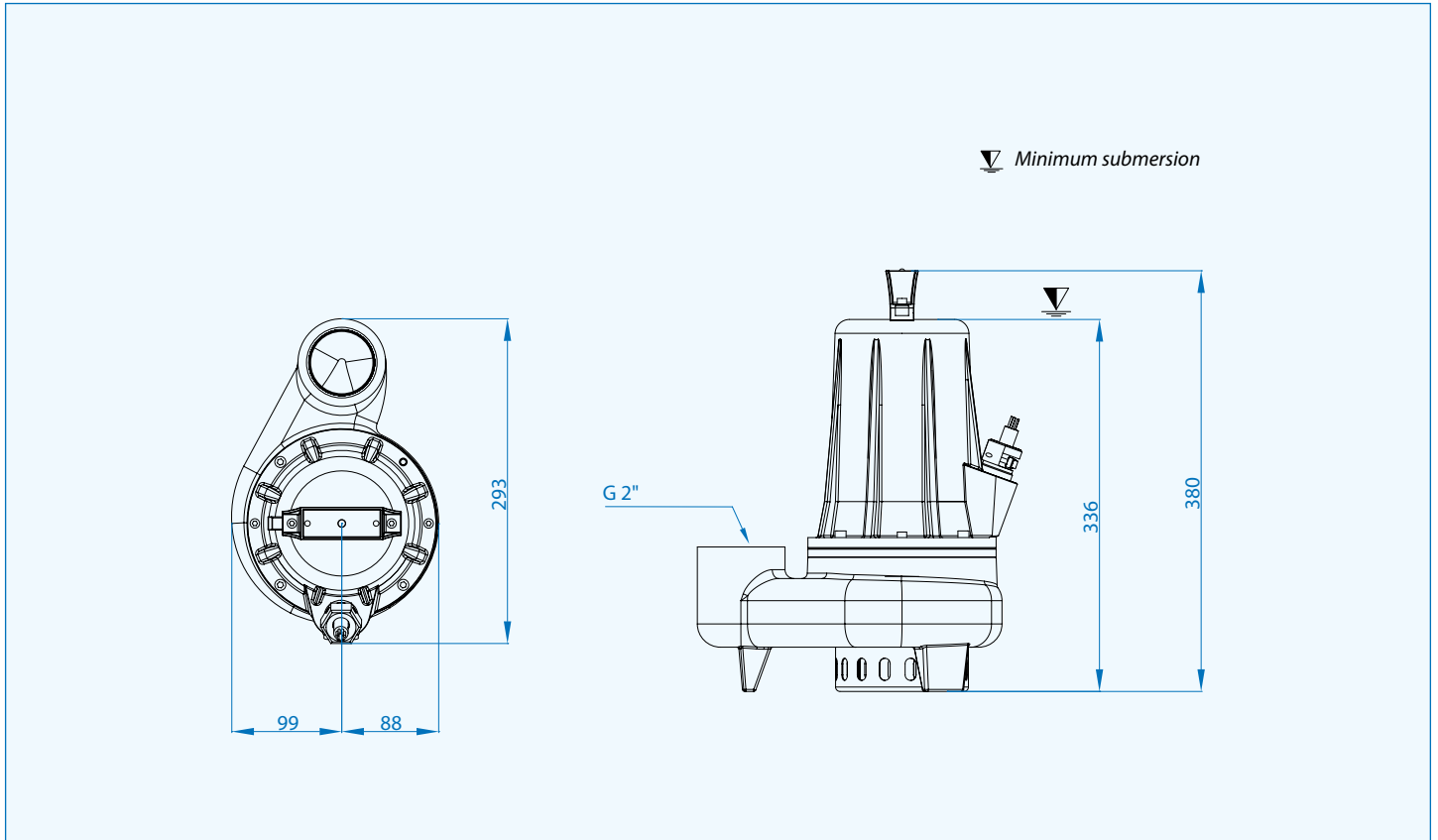

### Cables

Version	Phases	Cable	Cable cross section mm <sup>2</sup>	mt
Standard	1 ~ 230V	H07RN8F	4x1,5+2x0,50 Ø12 **	10
	3 ~ 400V		4x1,5+2x0,50 Ø12 *	10
ATEX	1 ~ 230V	NSSHÖU-J	4x1,5+2x0,50 Ø14 **	10
	3 ~ 400V		4x1,5+2x0,50 Ø14 *	10

\* with Free terminals

\*\* Standard with Control-box

### Optional



Hose connection 2"



Explosion proof control box available on request

### Packaging dimension

Type	X mm	Y mm	Z mm	Kg
BIC PRO 50-2/150	230	450	270	29
BIC PRO 50-2/220				26



### Horizontal Outlet - RPM 2850 1/min 2 poles

#### AM/AT-EX 40/2/110 C.218

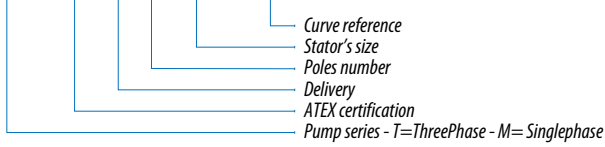

Picture for illustration purposes only



### Performance Curve

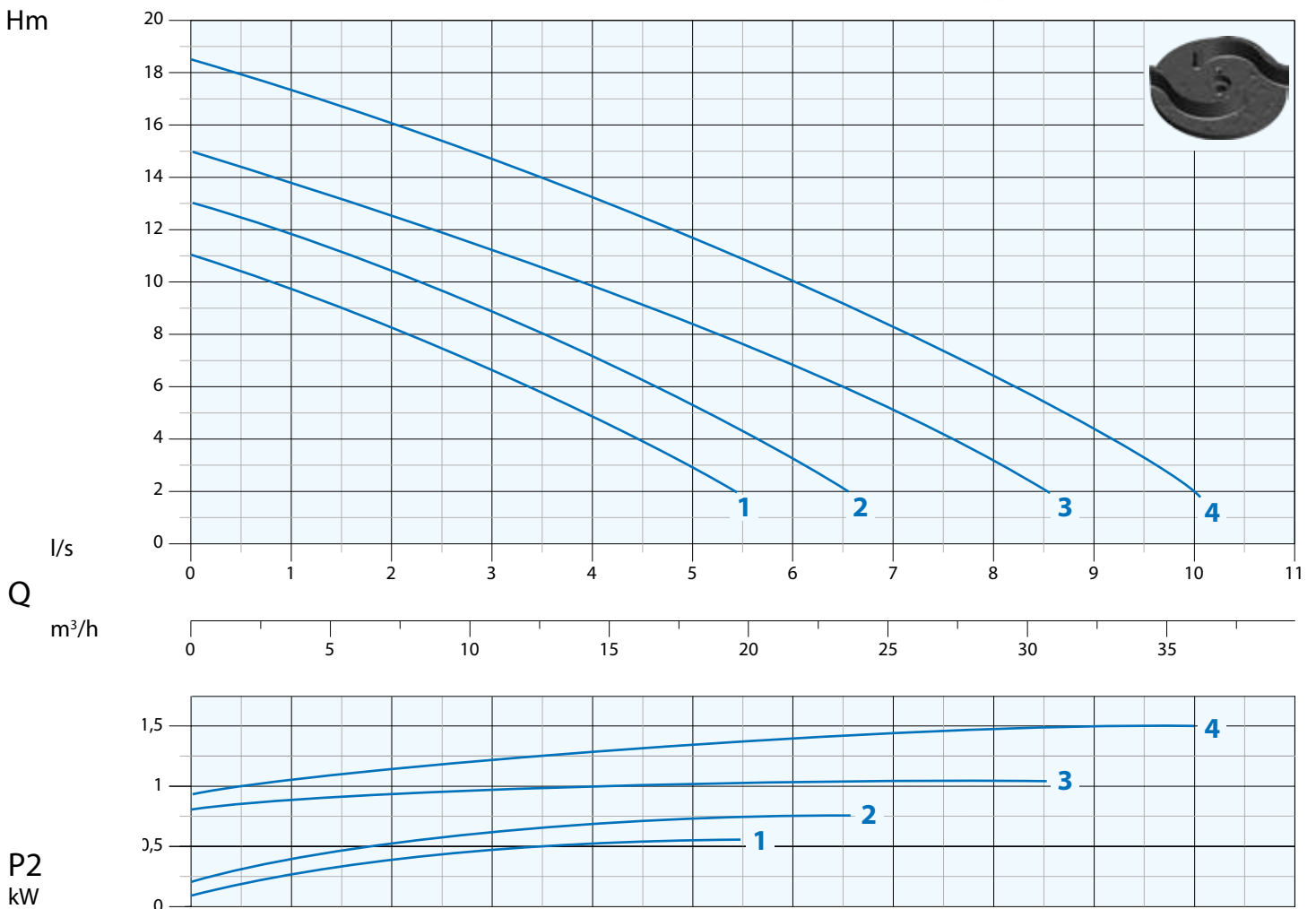

N°	Type	l/s											
			0,5	1	2	3	4	5	6	7	8	9	10
		l/m	30	60	120	180	240	300	360	420	480	540	600
		m³/h	1,8	3,6	7,2	10,8	14,4	18	21,6	25,2	28,8	32,4	36
1	AM-AT 40/2/110 C.218	mt	10,5	9,5	8,5	6,5	5	3					
2	AM-AT 40/2/110 C.219		12,5	12	10,5	9	7	5,2	3,5				
3	AM-AT 50/2/110 C.225		14,5	14	12,5	11	10	8,5	7	5	3		
4	AM-AT 50/2/110 C.226		18	17,5	16	14,5	13	11,5	10	8,5	6,5	4,5	2

N°	Type	EX	Delivery	Free Passage	kW			R.P.M. 1/min	A		
					P1	P2	HP		1 Phase - 230V	µf	3 Phase - 400V
1	AM-AT 40/2/110 C.218		G 1 <sup>m</sup> / <sub>2</sub>	20x10 mm	0,8	0,55	0,75	2850	3,9	16	1,9
2	AM-AT 40/2/110 C.219				0,9	0,75	1		4,3	20	2,0
3	AM-AT 50/2/110 C.225	•	G 2"	1,5	1,1	1,5	6,2		25	3,3	
4	AM-AT 50/2/110 C.226	•		1,8	1,5	2	9,6		40	3,5	

• Available explosion proof pump with certifications:



Ex db IIB T4 Gb  
Ex h IIB T4 Gb  
0° Ta 40°

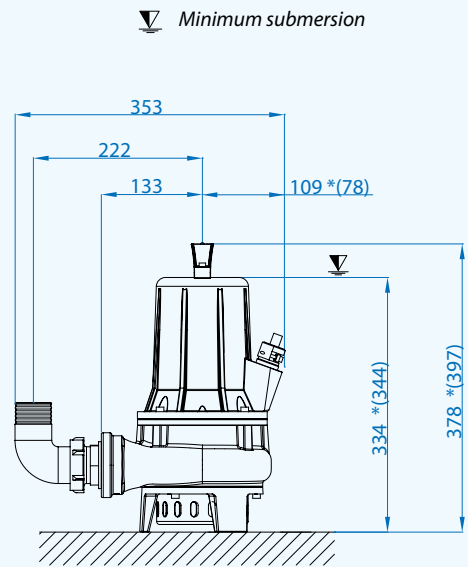
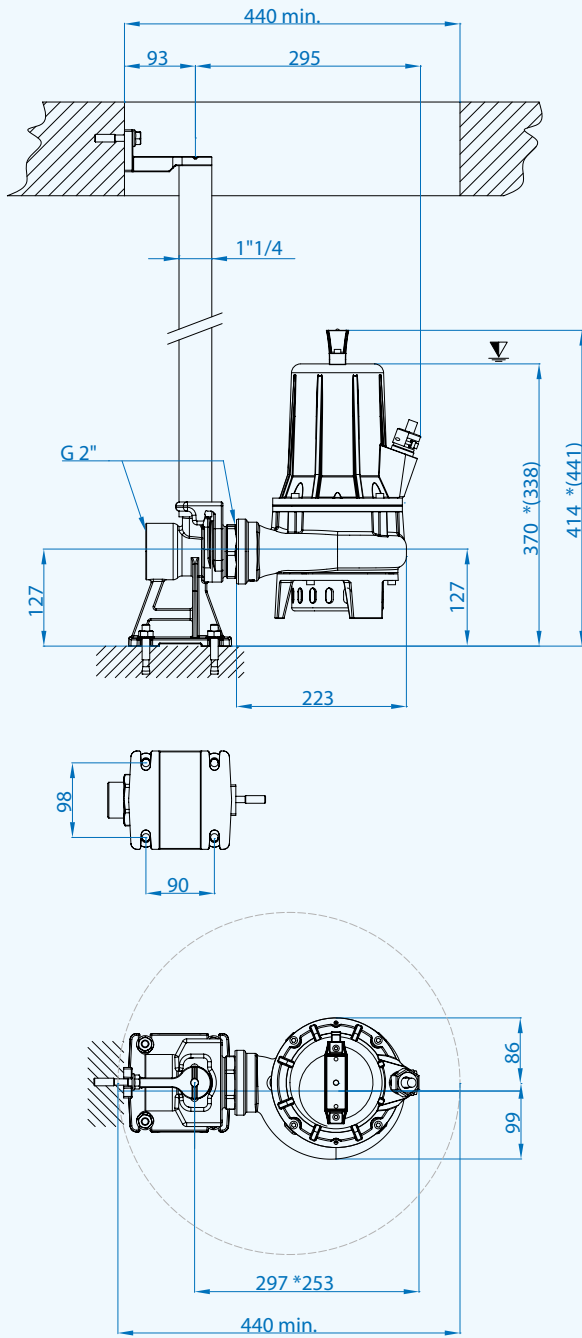

\*(AM-AT 40/2/110 C.218-219)

### Cables

Pumps	Version	Phases	Cable	Cable cross section mm <sup>2</sup>	mt
40/2/110	Standard	1 ~ 230V	H07RN8F	3x1 Ø9 *	10
		3 ~ 400V	H07RN8F	4x1 Ø10 **	10
50/2/110	Standard	1 ~ 230V	H07RN8F	4x1,5+2x0,50 Ø12 ***	10
		3 ~ 400V	H07RN8F	4x1,5+2x0,50 Ø12 **	10
	ATEX	1 ~ 230V	NSSHÖU-J	4x1,5+2x0,50 Ø14 ***	10
		3 ~ 400V	NSSHÖU-J	4x1,5+2x0,50 Ø14 **	10

\* with schuko plug

\*\* with Free terminals

\*\*\* Standard with Control-box

### Packaging dimension

Type	X mm	Y mm	Z mm	Kg
AM-AT 40/2/110 C.218	230	450	270	20
AM-AT 40/2/110 C.219				21
AM-AT 50/2/110 C.225				25
AM-AT 50/2/110 C.226				26

### Optional



Automatic coupling foot type EASY

C.218-219 EASY  
2.1/2.2 C,225-226 EASY  
3.1/3.2



Flanged hose connection

C.218-219 - 1 1/2  
C.225-226 - 2"



For single phase pumps: Control-box with external main capacitor only AM-AT 50/2/110 C.225-226



Explosion proof control box available on request



## Submersible electropumps with twin channel impeller

Power:	<b>0.9÷1.5 kW</b>
Delivery	<b>G 1<sup>1</sup>/<sub>4</sub> - DN32</b>



### Application

The APX Series is used to pump clear water or light sewage where high pressure is needed. This series is particularly suited to pumping water for fountains, waterparks, agricultural irrigation and farming.

### Characteristic

The main components are fabricated in cast iron GG20. The configuration has a lip seal fitted to the motor side, and a mechanical seal in oil chamber, on the impeller side.

### Motor range

- Squirrel cage motor in 2 poles version
- Thermal protection embedded in the winding
- Insulation class F: 155°
- Motor protection IP 68

### Motor cooling

The cooling of the motor is ensured by the liquid where the pump is submerged.

### Designation

**APX 32 - 2 / 110 M/T G**

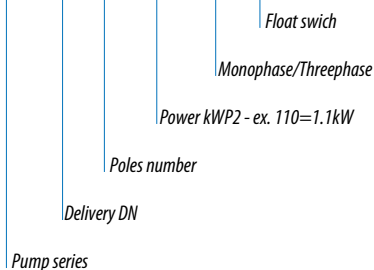

### Limits of use

- Max. permissible liquid temperature: +40° with pump fully submerged
- Maximum depth of immersion: 20 mt.
- Permissible pH value: 6-10
- Hydraulic features suitable for liquids with density < 1,1 kg/dm<sup>3</sup>
- Allowed voltage: 230V/400V ±5%
- Allowed frequency: 50Hz ±2%

### Performance Overview

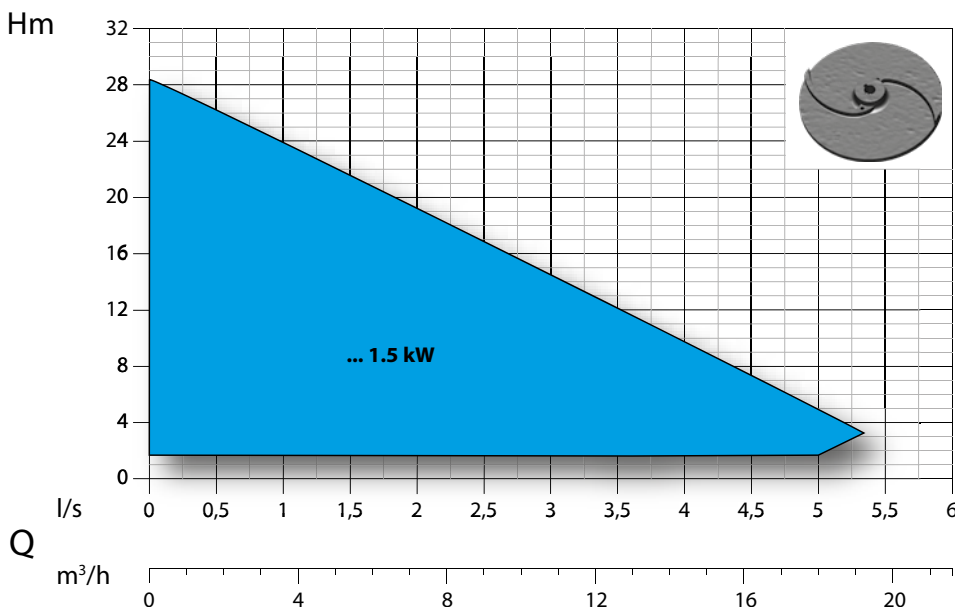

### Curves Identification

■ DN32 G 1<sup>1</sup>/<sub>4</sub>

### Norms

According to ISO 9906:2012 3B2

**List of components and materials**

- Handle*  
Hardened nylon
- Motor cover*  
Cast Iron GG20
- Capacitor*  
-
- Motor casing*  
Cast Iron GG20
- Motor shaft*  
Stainless steel AISI 420
- Electric motor*  
-
- Rotor*  
-
- Flange bearing support*  
Cast Iron GG20
- Seal kit*  
Motor side: lip seal  
Impeller side: silicon carbide/ceramic (SiC+CE/Viton)
- Impeller*  
Cast Iron GG20
- Body pump*  
Cast iron GG20
- Closing plate*  
Cast iron GG20
- Strainer*  
Stainless steel AISI 304

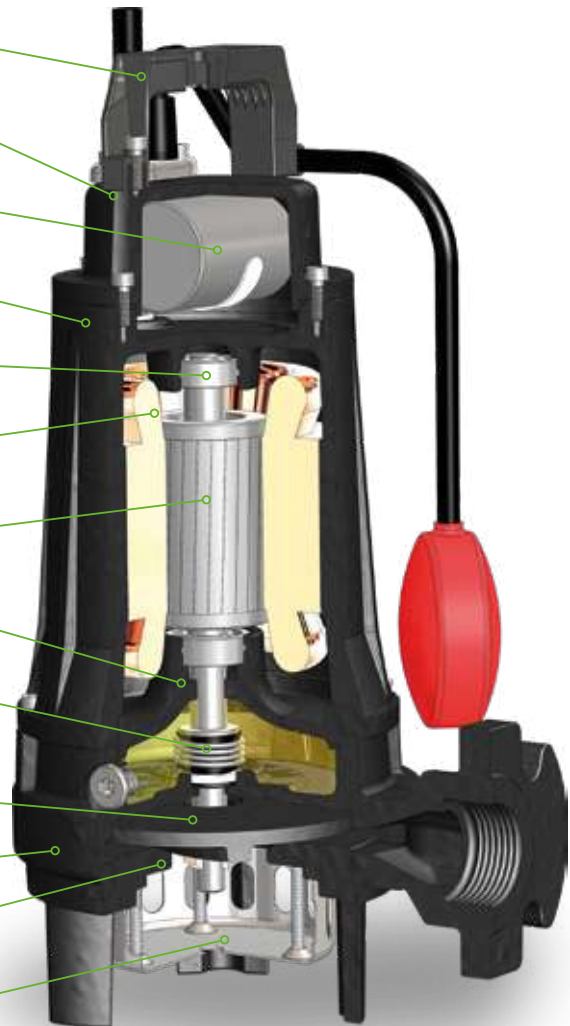

**Technology and Features**



*Twin channel impeller with strainer.  
Free passage up to 20x10 mm*



**Relay**  
*For the correct operation of the float switch on the three-phase version.*



*Flanged output DN32 PN6 with G 1 1/4 female thread*

### Horizontal Outlet DN32 PN6 - G 1"1/4 - RPM 2850 2 poles

Picture for illustration purposes only



### Performance Curve

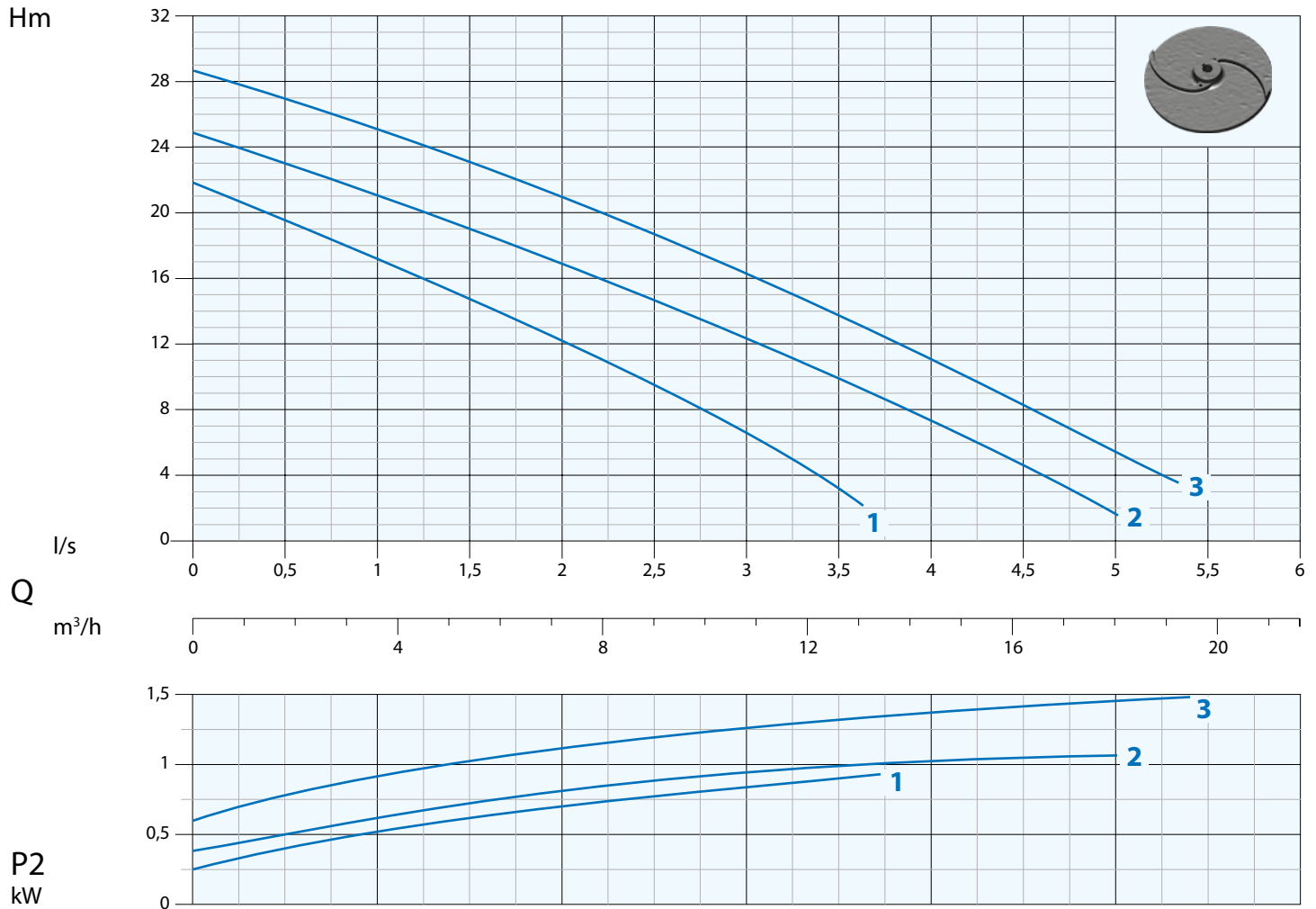

N°	Type		0,5	1	1,5	2	2,5	3	3,5	4	4,5	5
			l/s	l/m	m³/h	mt	mt	mt	mt	mt	mt	mt
1	APX 32-2/090 M/T		19,5	17	15	12	9,5	6,5	3			
2	APX 32-2/110 M/T		23	21	19	17	14,5	12,5	10	7	4,5	2
3	APX 32-2/150 M/T		27	25	23	21	18,5	16	14	11	8	5,5

N°	Type	Delivery	Free Passage	kW			R.P.M. 1/min	A			Hz
				P1	P2	HP		1 Phase - 230V	µf	3 Phase - 400V	
1	APX 32-2/090 M/T			1,2	0,9	1,2		5,4	25	2,4	
2	APX 32-2/110 M/T	DN32 PN6 G 1"1/4	20x10 mm	1,5	1,1	1,5	2850	8,5	30	3,2	50
3	APX 32-2/150 M/T			2,1	1,5	1,9		9,9	32	3,8	

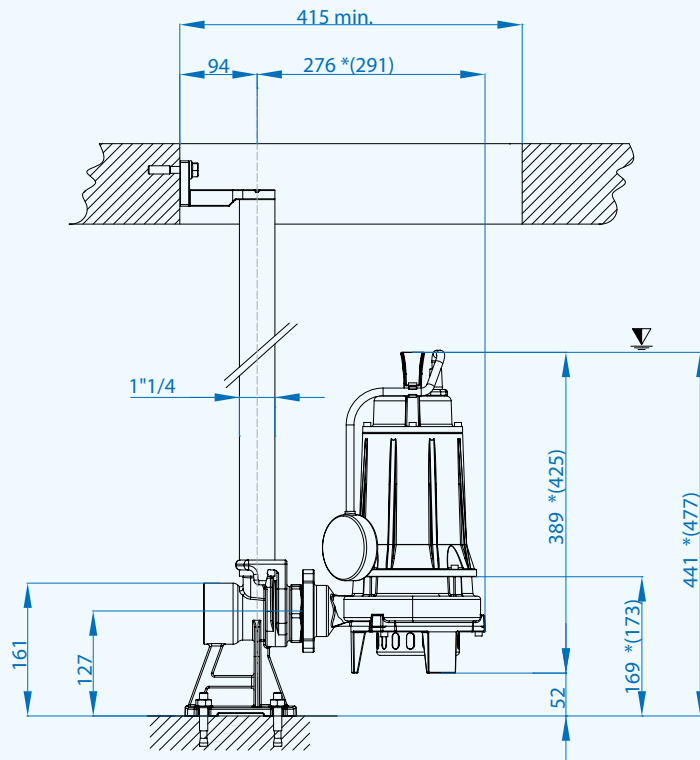

▽ Minimum submersion

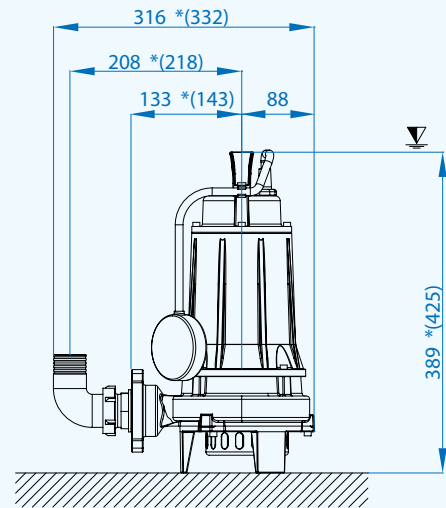

\*(APX 32-2/110-150)

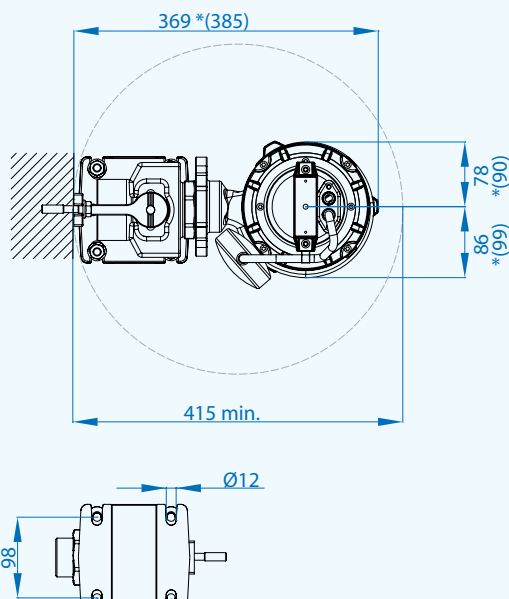

DN32 PN6  
ex UNI 2277  
G 1" 1/4

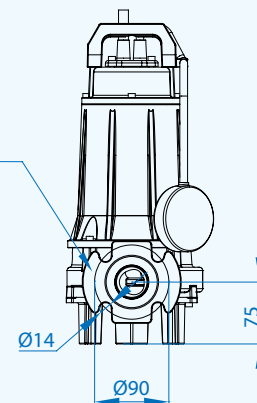

## Cables

Single phase 230V

H07RN8F 3x1 Ø9 - Schuko plug - Length 10 mt

Threephase 400V

H07RN8F 4x1 Ø10 - Free terminals - Length 10 mt

## Packaging dimension

Type	X mm	Y mm	Z mm	Kg
APX 32-2/090 M/T				20
APX 32-2/110 M/T	230	450	270	23
APX 32-2/150 M/T				25

## Optional



Automatic coupling foot  
Type: Duty 50 and EASY E1.1 - E 1.2



Thread hose connection  
1"1/4

# Submersible electropumps with twin and quad-channel

Power:	<b>1.5 ÷ 7.5 kW</b>
Delivery	<b>G 2" - DN65</b>



### Application

The H Series is used to pump clear water or light sewage where high pressure is needed. This series particularly suited to pumping water for fountains, waterparks, agricultural irrigation and farming.

### Characteristic

All main components are made of grey cast iron GG25. Two individual mechanical seals (motor side in the oil chamber, impeller side in contact with the liquid) and high quality parts, ensure the perfect functioning and reliability of the product.

### Motor range

- Squirrel cage motor at 2 poles
- Thermal protection T1 and T2 embedded in the motor winding (to be wired to the three pole contactor in the control panel)
- Class F insulation (155°C)
- IP 68 protection

### Motor cooling

The cooling of the motor is ensured by the liquid where the pump is submerged

### Limits of use

- Max. permissible liquid temperature: 40°C with pump fully submerged
- On request, special version (excluded ATEX) to withstand liquid temperature up to 60°C with pump fully submerged, no S1 service
- Maximum depth of immersion: 20 mt.
- Permissible pH value: 6-10
- Hydraulic features suitable for liquids with density <math>< 1,1 \text{ kg/dm}^3</math>
- Allowed voltage: 230V/400V-400V/690V  $\pm 5\%$
- Allowed frequency: 50Hz  $\pm 2\%$

### Designation

**HT-EX 65 / 2 / 152 C.503**

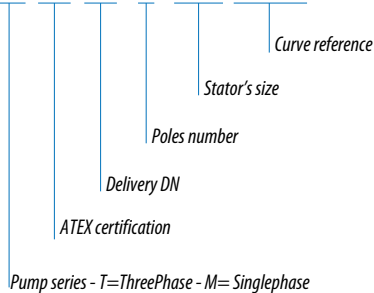

Pump series - T=ThreePhase - M= Singlephase

### Performance Overview

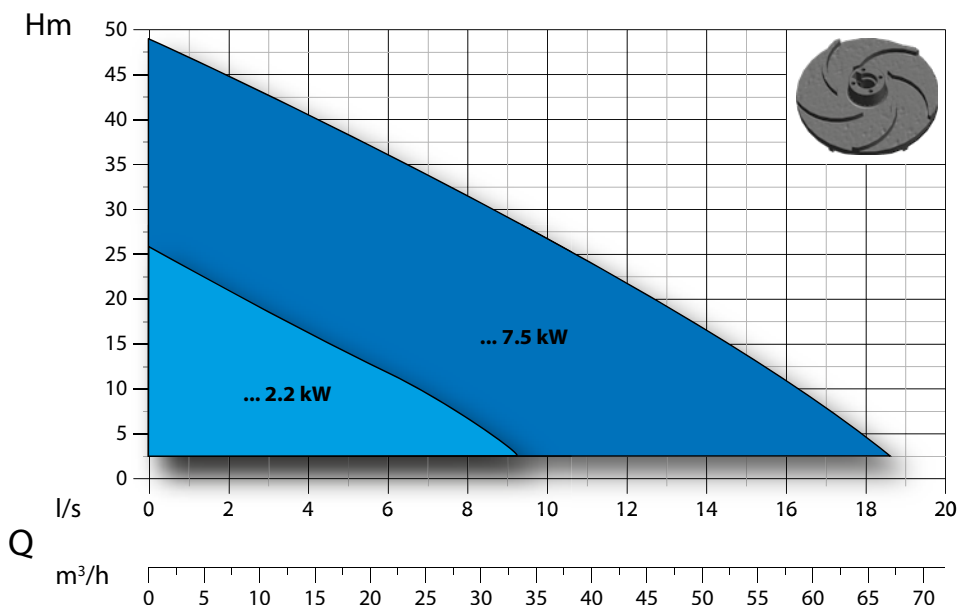

### Curves Identification

- G 2" DN50
- G 2" DN65

### Norms

According to ISO 9906:2012 3B2

### List of components and materials

Motor casing  
Cast Iron GG20

Motor shaft  
Stainless steel AISI 420

Electric motor  
-

Rotor  
-

Flange bearing support  
Cast Iron GG20

Mechanical seal  
Carbon/Ceramic (CA/CE/Viton)

Mechanical seal  
Silicon/Carbide (SIC/SIC/Viton)

Impeller  
Cast Iron GG20

Body pump  
Cast iron GG20

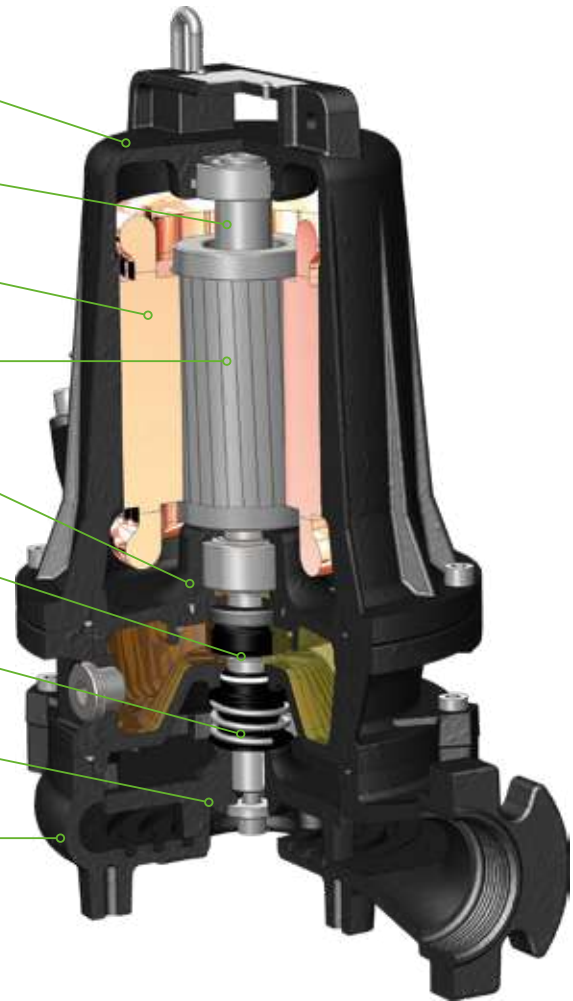

### Technology and Features

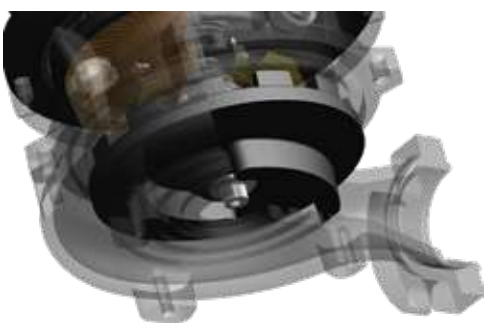

**Impellers**

The HT double-channel impeller are suitable for pumping very high pressure with free passage of solids up to 17 mm.



**Explosion proof pumps**



EPT 17 ATEX 2702 X

Pumps with explosion proof available on request.



II 2G

Ex db IIB T4 Gb  
Ex h IIB T4 Gb  
0° ~ Ta ~ 40°



**Seal leak detector**

The seal leak detector is certified according to the norm ATEX EN 60079-0, EN 60079-1 (through safety barrier) and fitted standard on all series.



**Cable gland**

The cable gland is made of stainless steel AISI 316 and certified according to the norm ATEX EN 60079-0, EN 60079-1. Standard on all series.

### Horizontal Outlet G 2" - RPM 2850 2 poles

Picture for illustration purposes only



### Performance Curve

L maximum pump efficiency

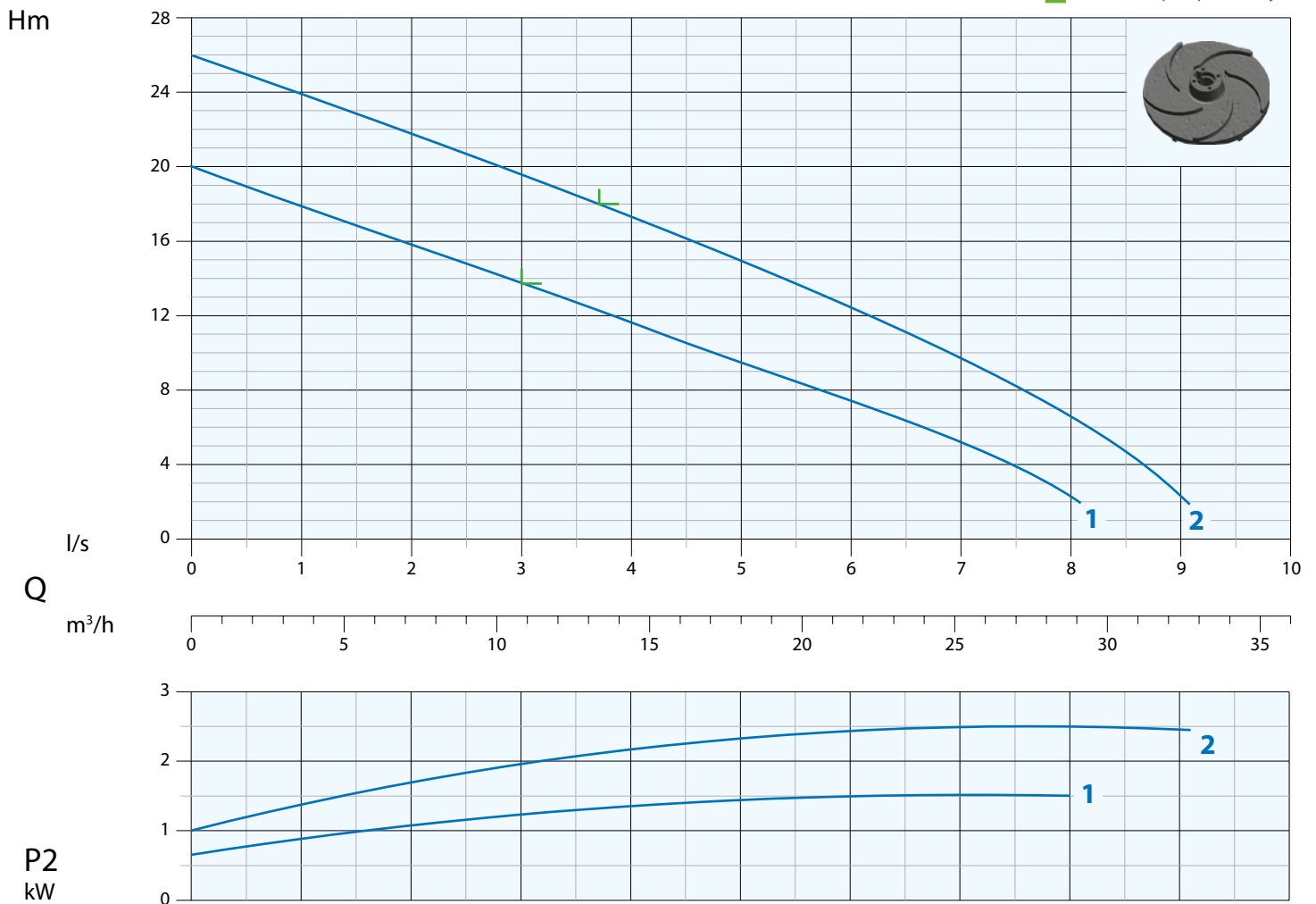

N°	Type	l/s	0,5	1	2	3	4	5	6	7	8	9
			l/m	30	60	180	180	240	300	360	420	480
		m³/h	1,8	3,6	10,8	10,8	14,4	18	21,6	25,2	28,8	32,4
1	HM-HT 50/2/125 C.500	mt	19	18	16	14	11,5	9,5	7,5	5	2	
2	HT 50/2/125 C.501		25	24	22	19,5	17	15	12,5	9,5	6,5	2

N°	Type	EX	Delivery	Free Passage	kW			HP	R.P.M. 1/min	A			Hz
					P1	P2				1 Phase - 230V	µf	3 Phase - 400V	
1	HM-HT 50/2/125 C.500	•	G 2" (female)	17 mm	2,2	1,5	2	2850	10,5	35	3,8	50	
2	HT 50/2/125 C.501	•			3,0	2,2	3		5,2				

• Available explosion proof pump with certifications:



EPT 17 ATEX 2702 X



II 2G Ex db IIB T4 Gb  
Ex h IIB T4 Gb  
0° Ta ~ 40°

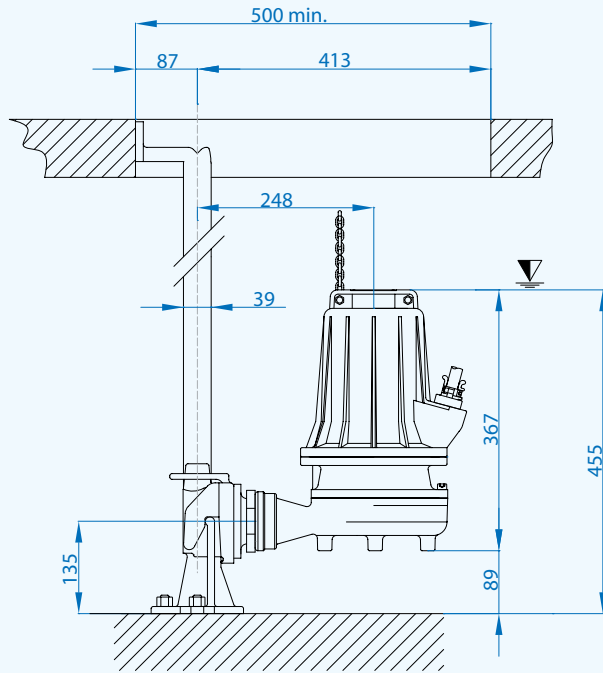

▽ Minimum submersion

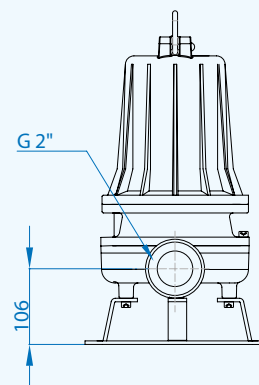
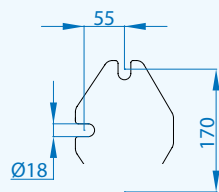
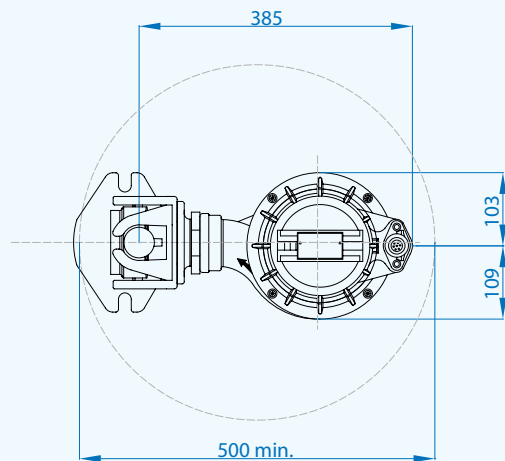
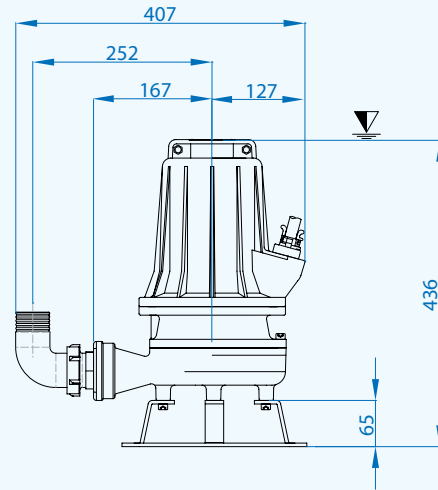

### Cables

Version	Phases	Cable	Cable cross section mm <sup>2</sup>	mt
Standard	1 ~ 230V	H07RN8F	4x1,5+3x0,50 Ø15*	10
ATEX		NSSHÖU-J	4x1,5+3x0,50 Ø16,5*	10
Standard	3 ~ 400V	H07RN8F	4x1,5+3x0,50 Ø15**	10
ATEX		D.O.L.	NSSHÖU-J	4x1,5+3x0,50 Ø16,5**

\* Standard with Control-box \*\*Free terminals

### Packaging dimension

Type	X mm	Y mm	Z mm	Kg
HM-HT 50/2/125 C.500	295	460	330	35
HT 50/2/125 C.501				36

### Optional



Automatic coupling foot  
Type: EASY E 3.1 - E 3.2



Thread hose connection 2"  
Foot support P4 DN65



Stainless steel handle



Explosion proof control box available on request



### Horizontal Outlet DN65 PN6 - RPM 2850 2 poles

Picture for illustration purposes only



maximum pump efficiency

### Performance Curve

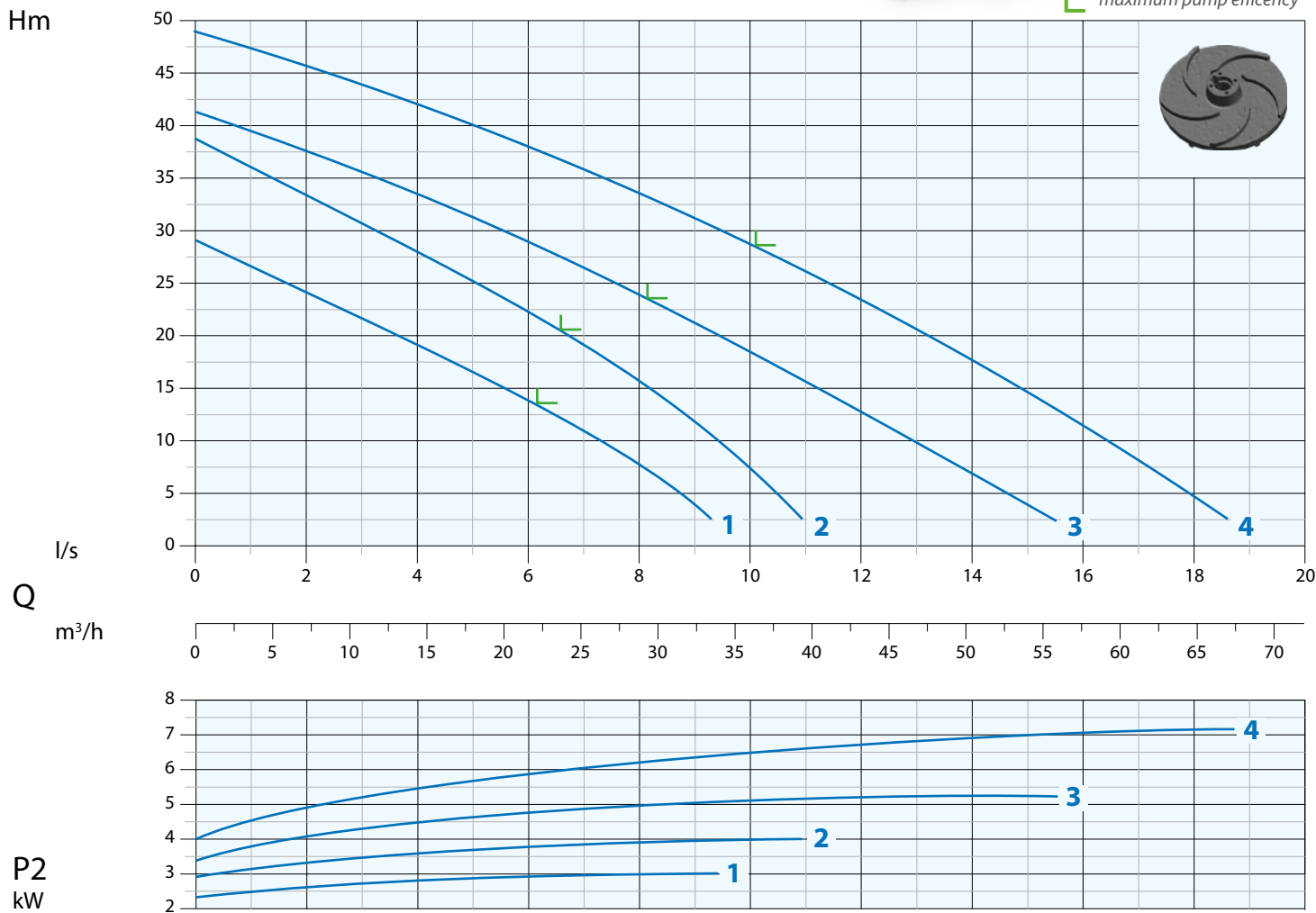

N°	Type											
		l/s	1	2	4	6	8	10	12	14	16	18
		l/m	60	120	360	360	480	600	720	840	960	1080
		m³/h	3,6	7,2	21,6	21,6	28,8	36	43,2	50,4	57,6	64,8
1	HT 65/2/152 C.502	mt	25,5	23	18,5	13,5	7,5					
2	HT 65/2/152 C.503		36,5	33	27,5	22,5	16	7,5				
3	HT 65/2/173 C.504		39,5	37,5	33	28	23	18	12,5	7		
4	HT 65/2/173 C.505		47	46	42,5	37,5	33	28,5	23	17,5	12	5

N°	Type	EX	Delivery	Free Passage	kW			R.P.M. 1/min	A 3 Phase - 400V	Hz
					P1	P2	HP			
1	HT 65/2/152 C.502	•	DN65 PN6	10 mm	4,3	3,2	4	2850	7,5	50
2	HT 65/2/152 C.503	•			5,4	4,2	5,5		9,4	
3	HT 65/2/173 C.504	•			7,4	5,5	7,5		12,5	
4	HT 65/2/173 C.505	•			9,3	7,5	10		15,5	

• Available explosion proof pump with certifications:



EPT 17 ATEX 2702 X



Ex db IIB T4 Gb  
Ex h IIB T4 Gb  
0° - Ta 40°

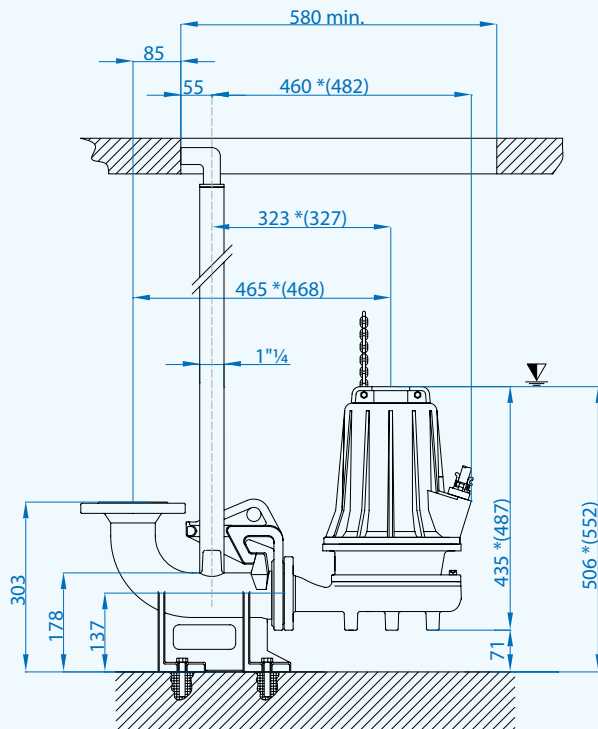

∇ Minimum submersion

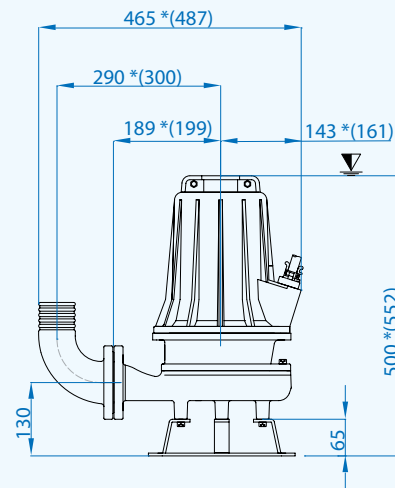

\*(HT 50/2/173 C.504-505)

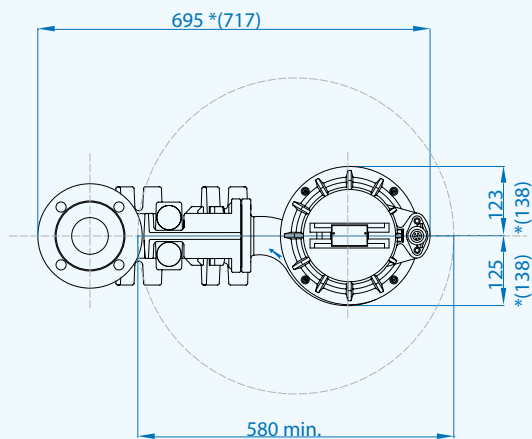

DN65 PN6  
ex UNI 2278

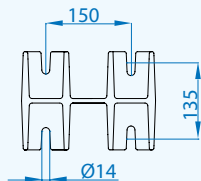
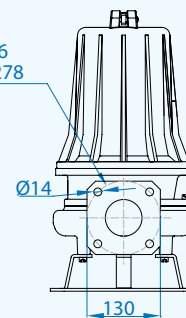

### Cables

Pumps	Version	Phases	Cable	Cable cross section mm <sup>2</sup>	mt
65/2/152	Standard	3 ~ 400V	H07RN8F	4x1,5+3x0,50 Ø15*	10
	ATEX	D.O.L.	NSSHÖU-J	4x1,5+3x0,50 Ø17*	10
65/2/173	Standard	3 ~ 400V	H07RN8F	7x1,5+3x0,50 Ø17*	10
	ATEX	Y-Δ	NSSHÖU-J	7x1,5+3x0,50 Ø17*	10

\* Free terminals

### Packaging dimension

Type	X mm	Y mm	Z mm	Kg
HT 65/2/152 C.502	335	580	420	53
HT 65/2/152 C.503				57
HT 65/2/173 C.504				85
HT 65/2/173 C.505				85

### Optional



Automatic coupling foot  
Type: B4 PN6



Flanged hose connection N1  
Foot support P4 DN65



Stainless steel handle

## Submersible contractor electropumps with channel impeller

Power:	0.4÷11 kW
Delivery	G 2" - G 3" - G 4"



### Designation

**KPM 50.04 M/T**

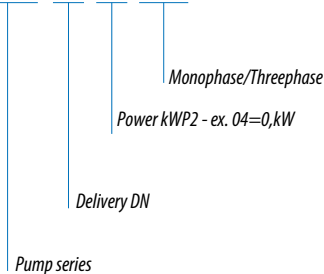

### Application

The submersible portable pump has an abrasion-resistant Vortex impeller. It is ideal for use in civil and industrial building sites, mines and flooded areas.

### Characteristic

Impellers are of multiblade type in stainless steel and the wearing parts are covered in anti-abrasion rubber.

### Motors:

All single-phase motors are fitted with thermal protection embedded in the winding (bi-metal type) which ensure a prompt cut-off in case of over-temperature. The capacitor is built-in within the pump. All three-phase motors are fitted with thermal-amps. overload protection which ensure a prompt cut-off in case of over-temperature.

### Motor cooling

The cooling of these pumps is ensured by the cooling jacket which provides a high degree of heat dissipation.

### Limits of use

- Max. permissible liquid temperature: +40° with pump fully submerged
- Maximum depth of immersion: 20 mt.
- Permissible pH value: 6-10
- Hydraulic features suitable for liquids with density <math>< 1,1 \text{ kg/dm}^3</math>
- Allowed voltage: 230V/400V  $\pm 5\%$
- Allowed frequency: 50Hz  $\pm 2\%$

### Performance Overview

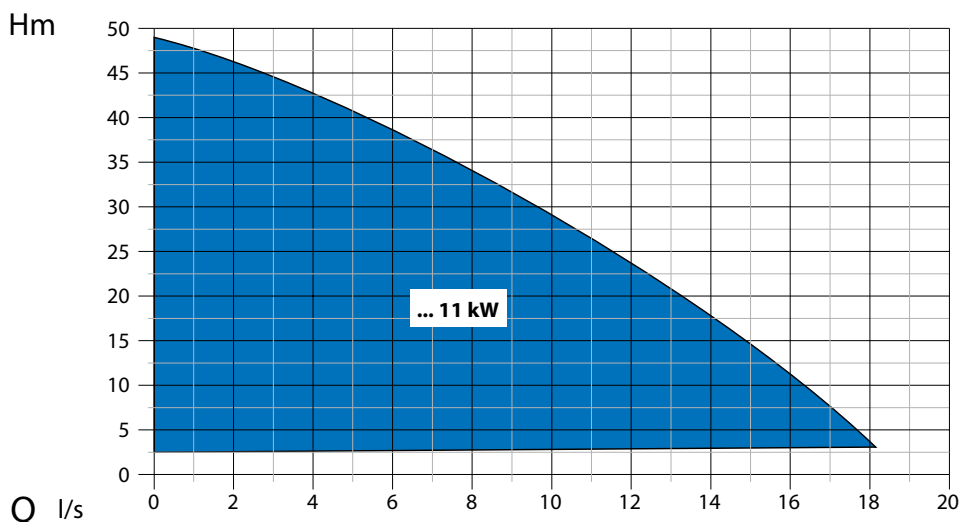

### Impellers

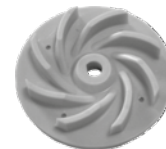

Series KPM 50.04 - 07 feature stainless steel impeller embedded in a DUPONT patented anti-abrasion rubber



High chrome stainless steel impeller

### Norms

According to ISO 9906:2012 3B2

List of components and materials

**KPM 50.04 - 07**

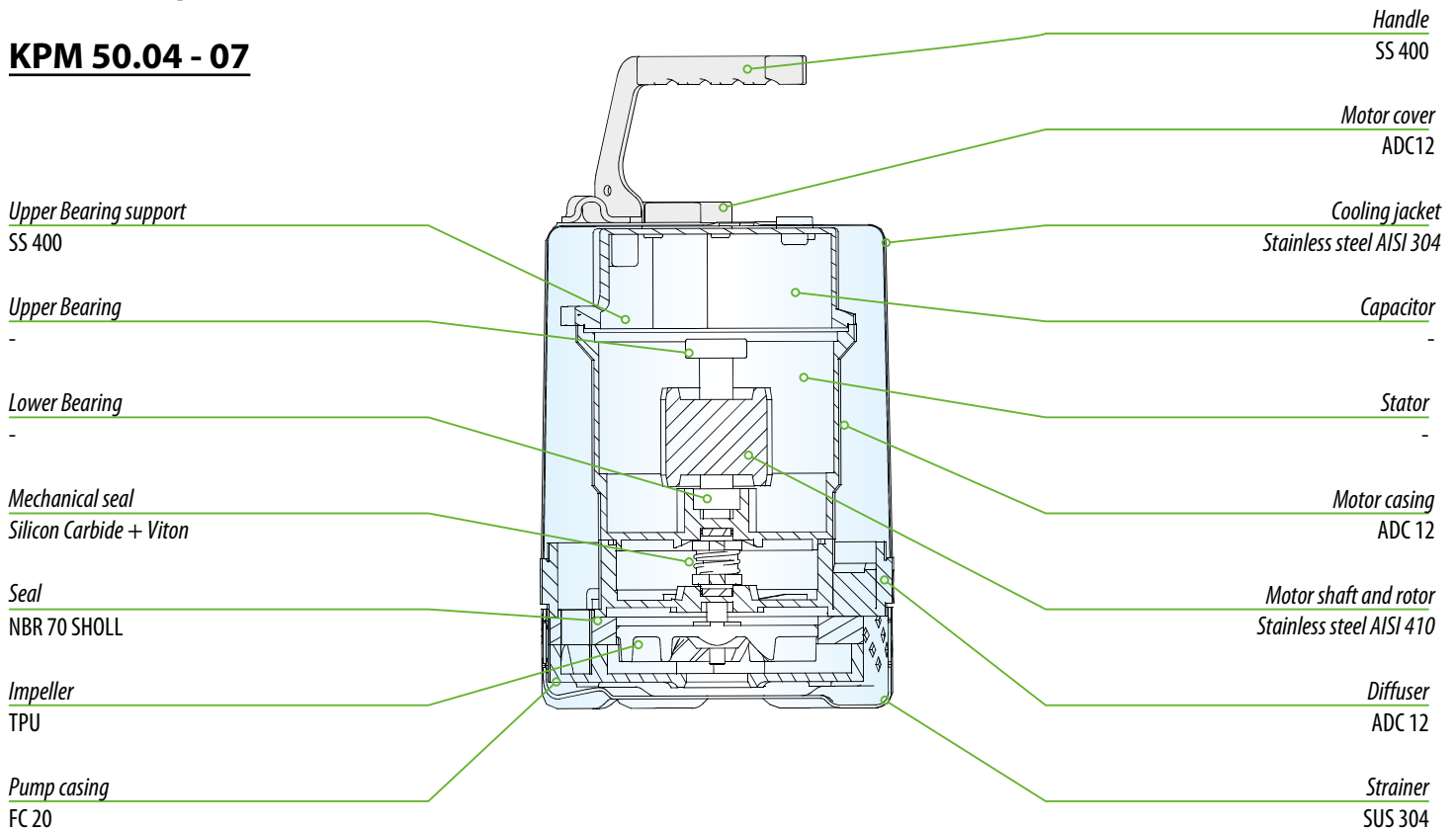

**KPM 50.15**  
**KPM 80.22 - 37**  
**KPM 100.55 - 110**

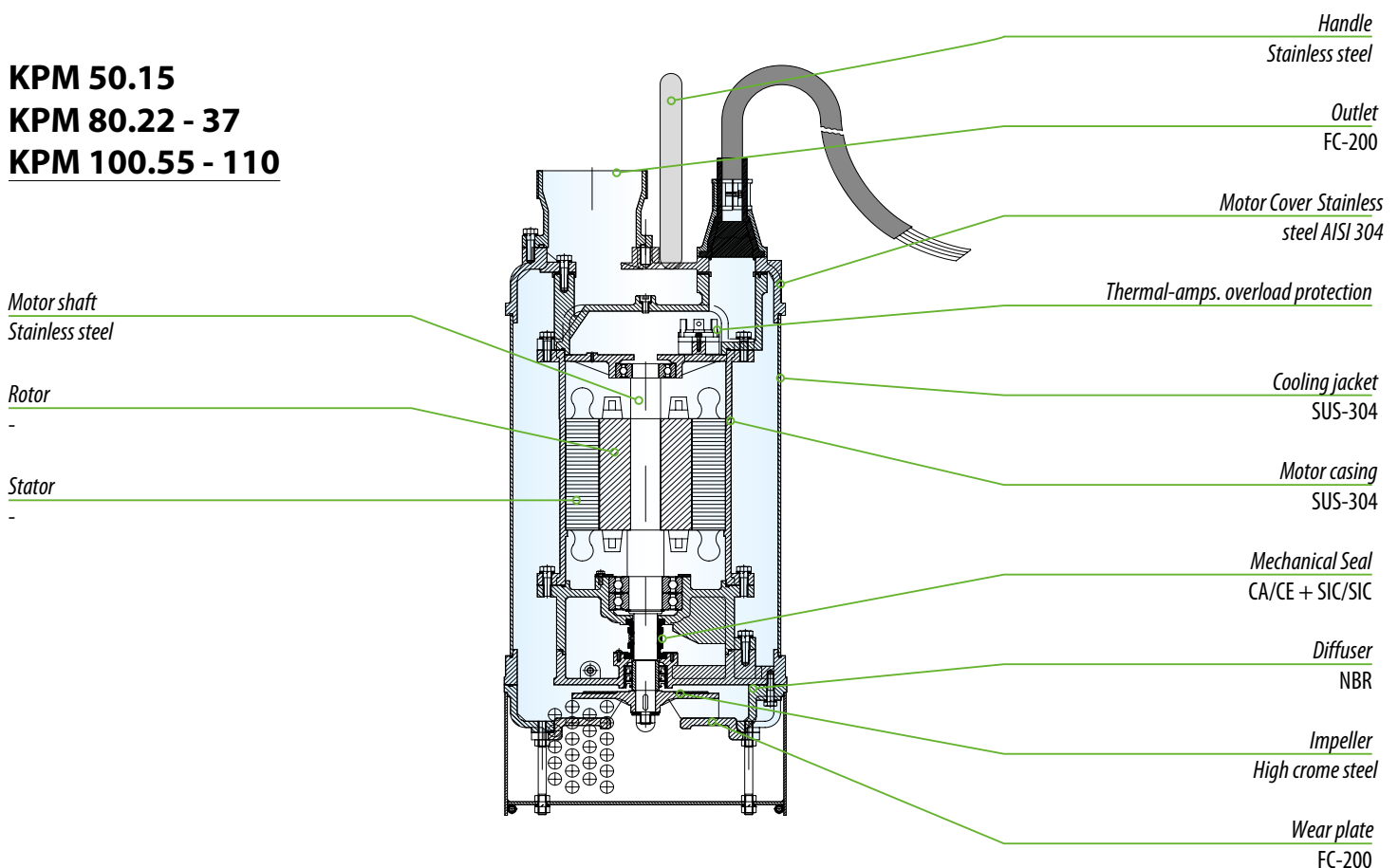

### Vertical Outlet G2" - RPM 2850 2 poles

**50.04-07**

Picture for illustration purposes only



### Performance Curve

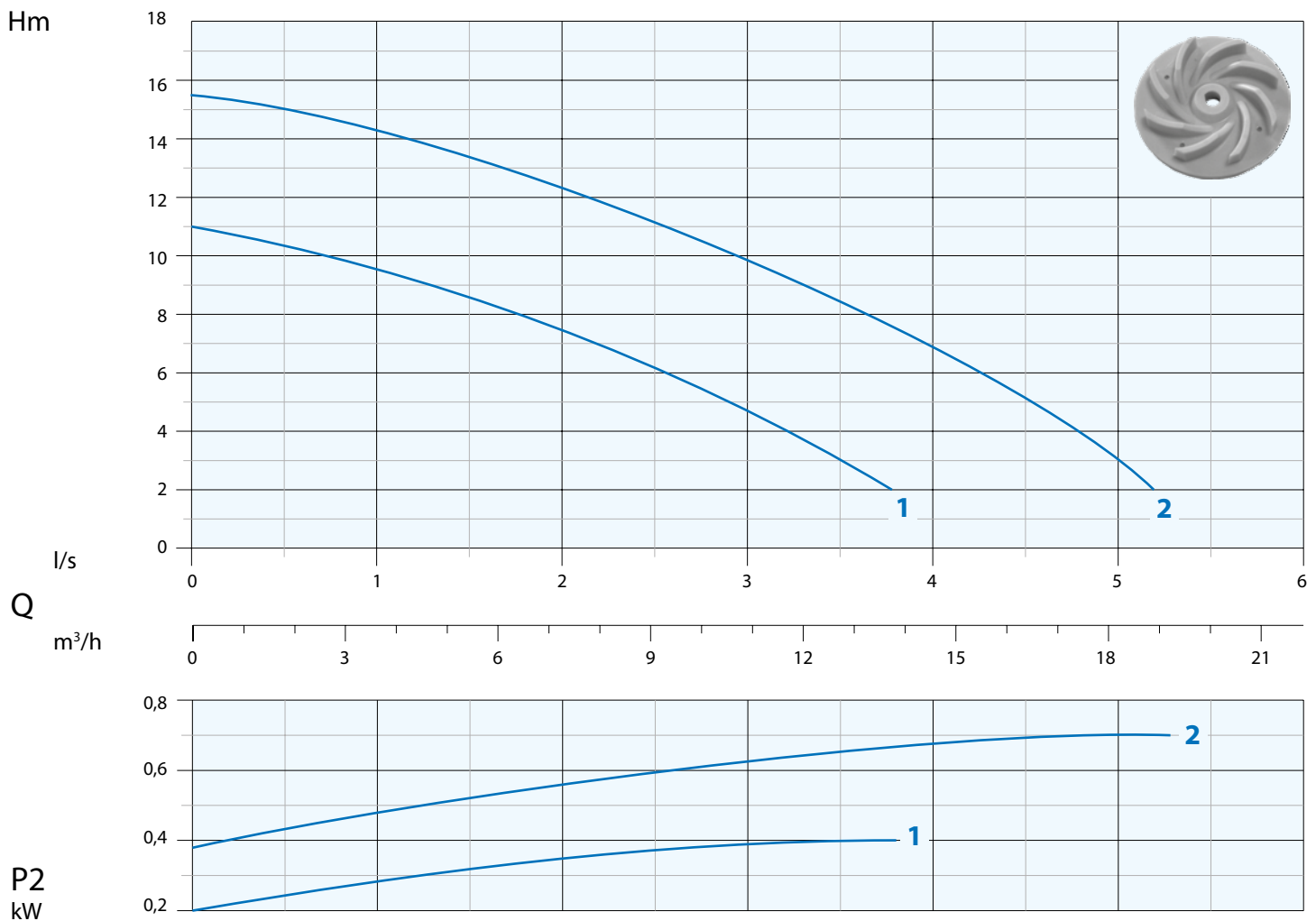

N°	Type	l/s	0,5	1	1,5	2	2,5	3	3,5	4	5
			l/m	30	60	90	120	150	180	210	240
		m³/h	1,8	3,6	5,4	7,2	9	10,8	12,6	14,4	18
1	KPM 50.04 M	mt	10,5	9,5	8,5	7,5	6	4,5	3		
2	KPM 50.07 M		14,5	14,5	13,5	12,5	11	10	8,5	7	3

N°	Type	Delivery	Free Passage	kW		HP	R.P.M. 1/min	A		Hz
				P1	P2			1 Phase - 230V	µf	
1	KPM 50.04 M	G 2" maschio o portagomma	5x5 mm	0,48	0,4	0,5	2850	3	12	50
2	KPM 50.07 M	G 2" male or hose connection		0,78	0,75	1		5,4	20	

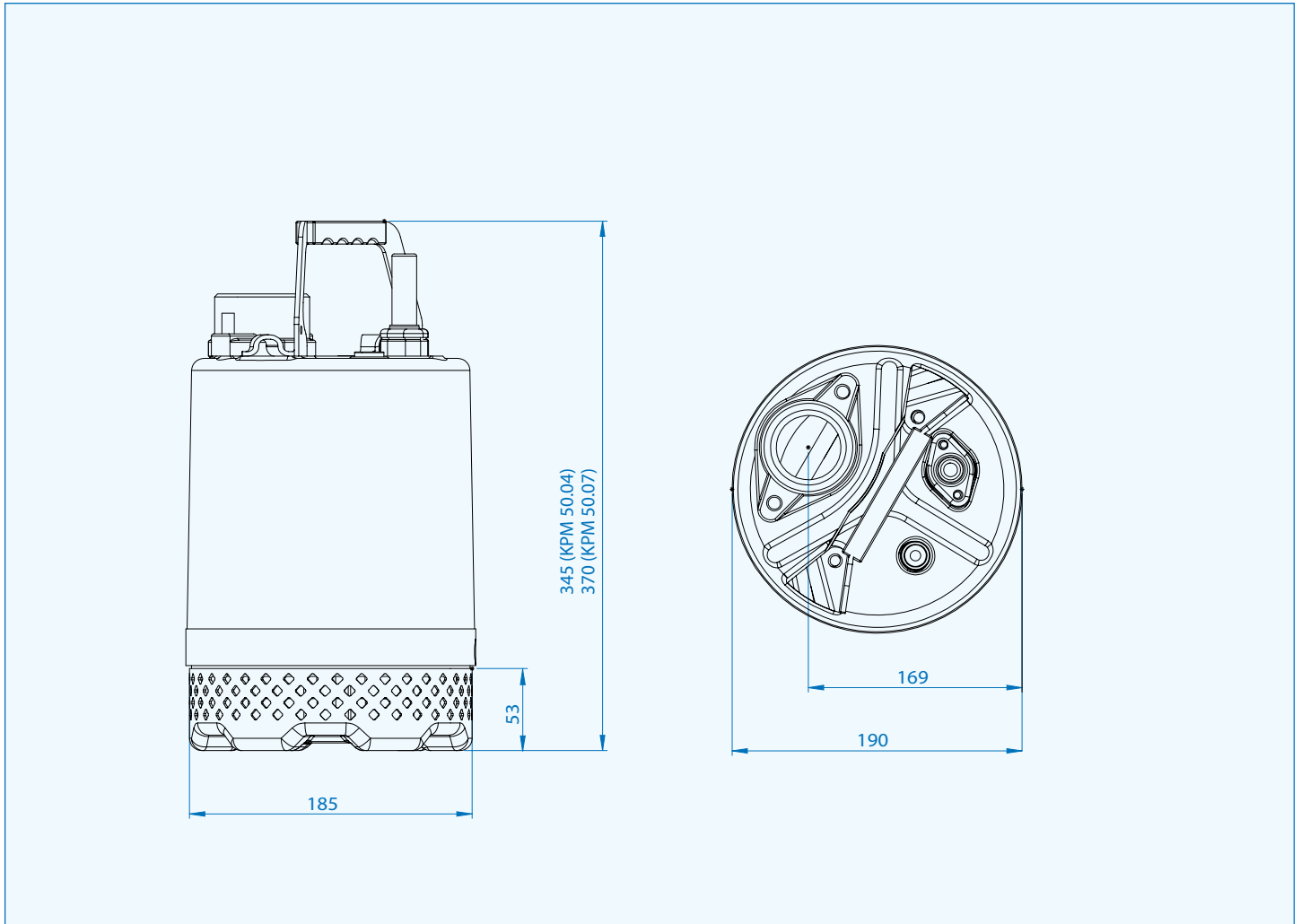

**Cables**

Single phase 230V  
 H07RNF 3x1 - Schuko plug - Length 10 mt

Pumps supplied with thread connection and hose connection output

**Packaging dimension**

Type	X mm	Y mm	Z mm	Kg
KPM 50.04 M	300	460	200	14
KPM 50.07 M	300	500	200	20



## Vertical Outlet G2" - RPM 2850 2 poles

### 50.15

Picture for illustration purposes only



### Performance Curve

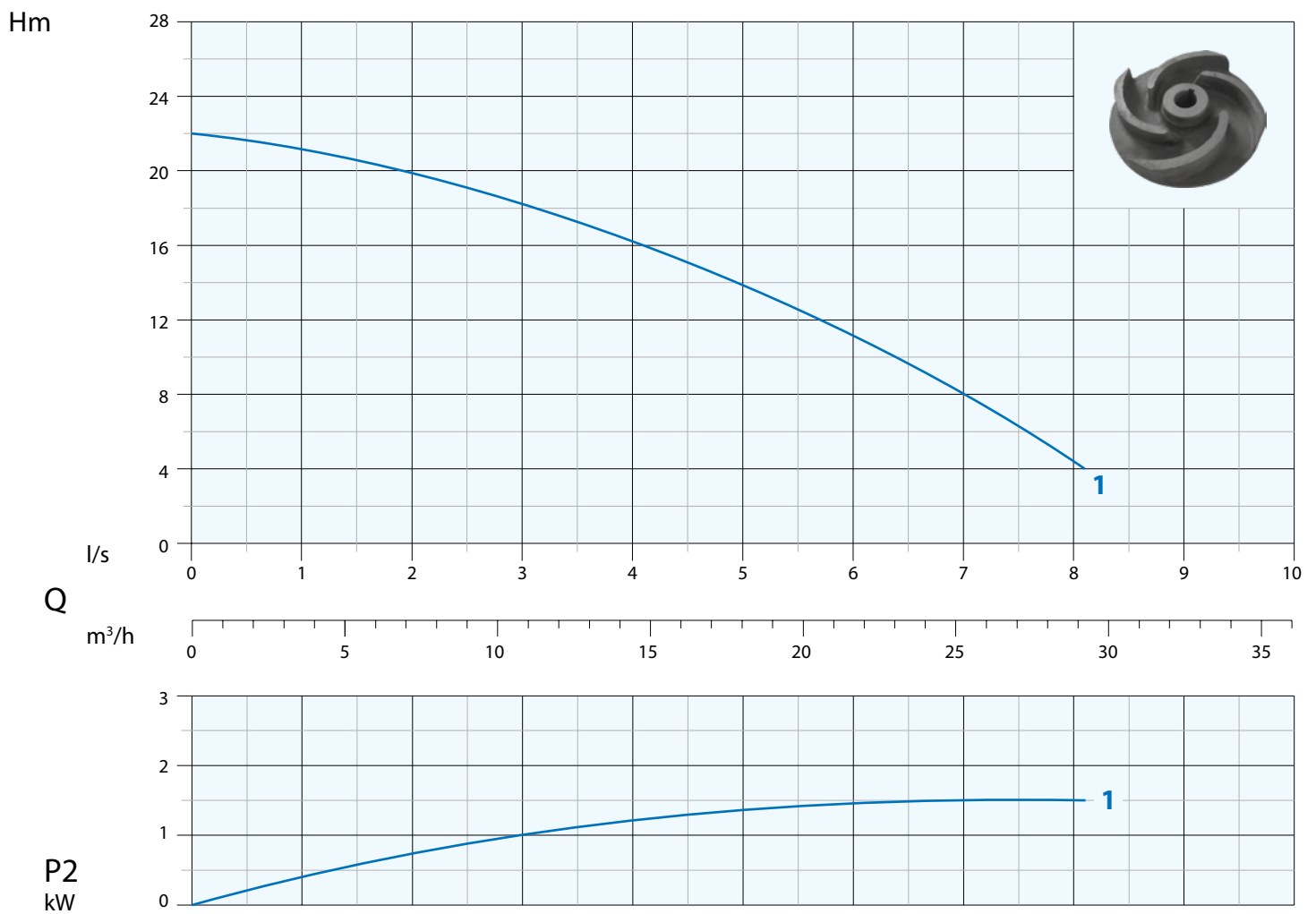

N°	Type	I/s	0,5	1	2	3	4	5	6	7	8
		l/m	30	60	120	180	240	300	360	420	480
		m³/h	1,8	3,6	7,2	10,8	14,4	18	21,6	25,2	28,8
1	KPM 50.15 M/T	mt	21,5	21	20	18	16	14	11	8	4

N°	Type	Delivery	Free Passage	kW		HP	R.P.M. 1/min	A		Hz	
				P1	P2			1 Phase - 230V	3 Phase - 400V		
1	KPM 50.15 M/T	G 2" male	Ø 9 mm	2	1,5	2	2850	10	30	3,3	50

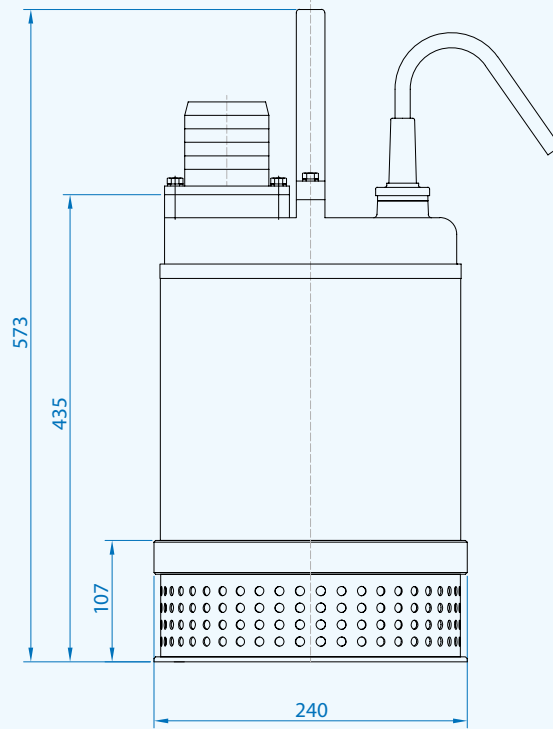

**Cables**

Single phase 230V  
 H07RNF 3x1 - Schuko plug - Length 10 mt  
 Threephase 400V  
 H07RNF 4x1 - Free terminals - Length 20 mt

**Optional**



Output with hose connection

**Packaging dimension**

Type	X mm	Y mm	Z mm	Kg
<b>KPM 50.15 M/T</b>	350	690	270	29,5





### Vertical Outlet G3" - RPM 2850 2 poles

**80.22-37**

Picture for illustration purposes only



#### Performance Curve

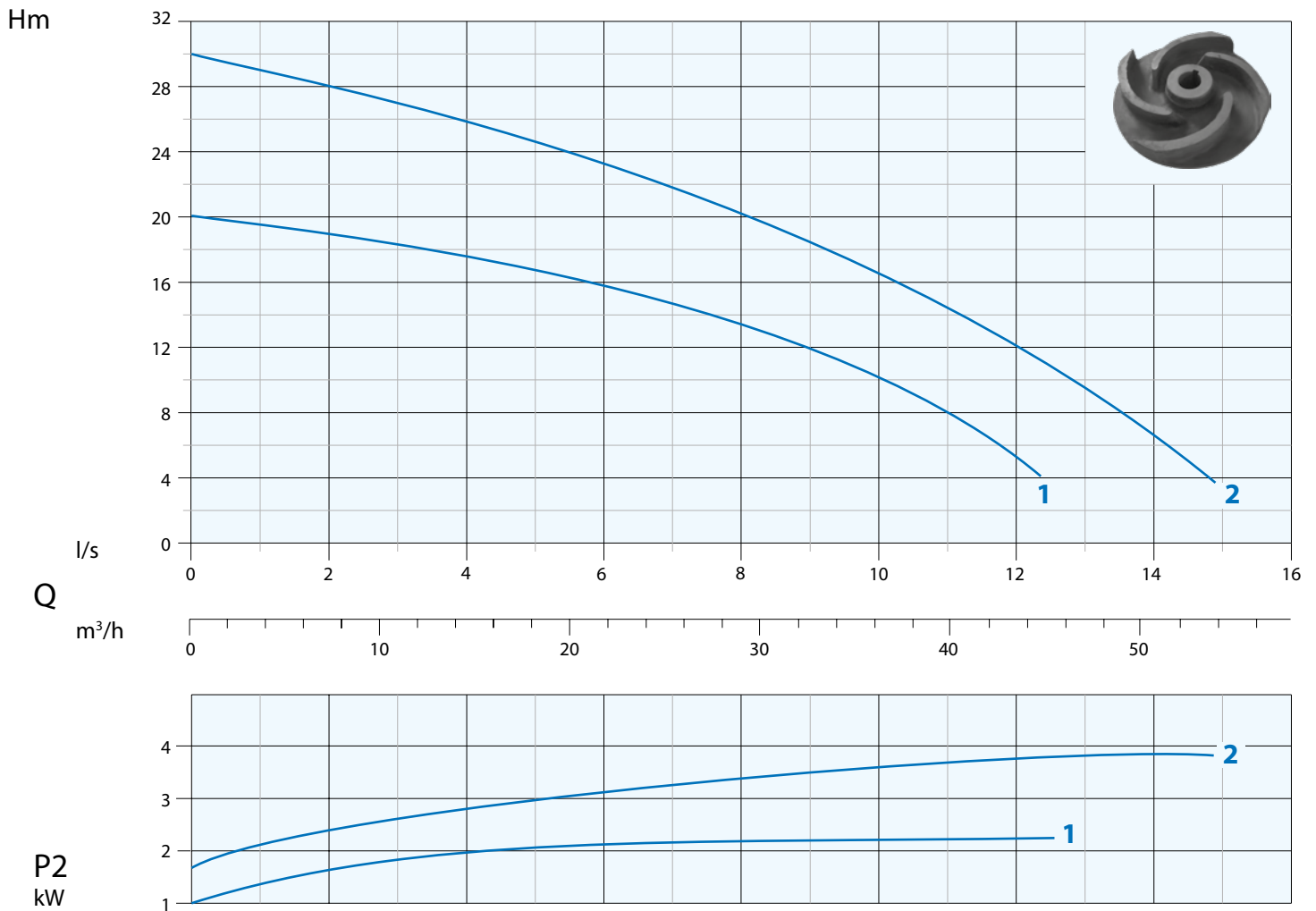

N°	Type	l/s	1	2	4	6	8	10	12	14	15
			l/m	60	120	240	360	480	600	720	840
		m³/h	3,6	7,2	14,4	21,6	28,8	36	43,2	50,4	54
1	KPM 80.22 T	mt	19,5	19	17,5	16	13	10	5		
2	KPM 80.37 T		29	28	26	23	20	17	12	7	4

N°	Type	Delivery	Free Passage	kW		HP	R.P.M. 1/min	A 3 Phase - 400V	Hz
				P1	P2				
1	KPM 80.22 T	G3" male	Ø 9 mm	3	2,2	3	2850	5	50
2	KPM 80.37 T			5	3,7	5		8,3	

**KPM 80.22**

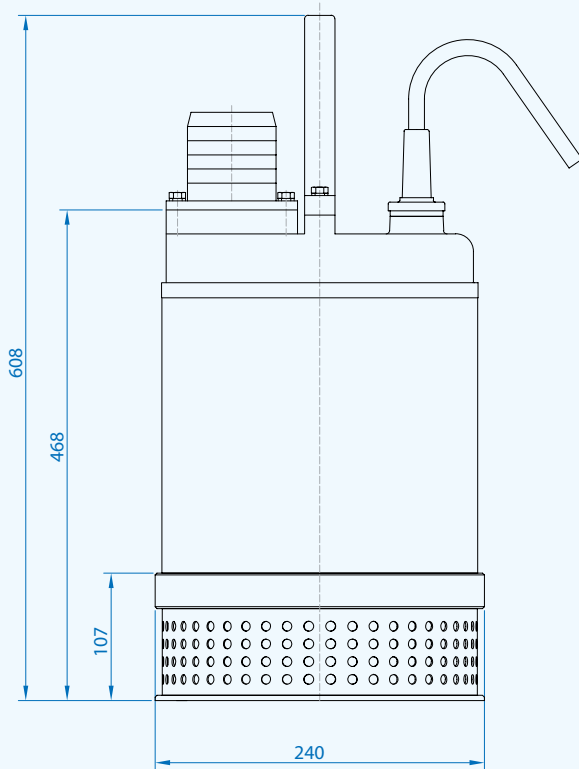

**KPM 80.37**

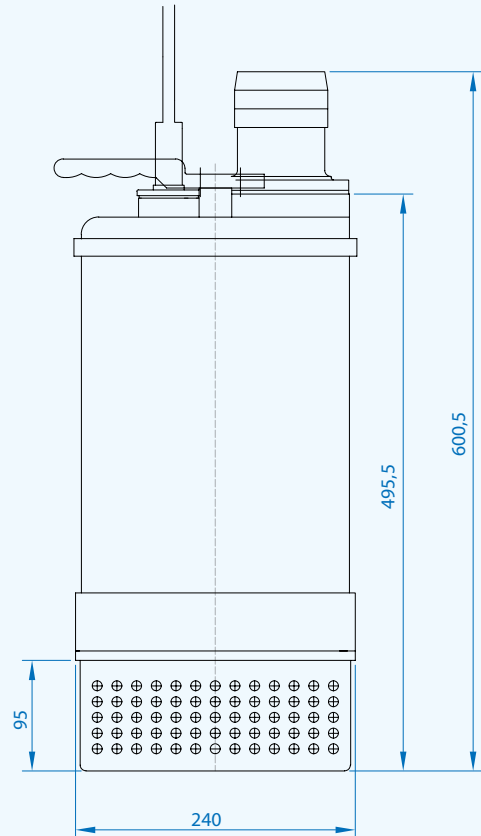

**Cables**

Pumps	Phases	Cable	Cable cross section mm <sup>2</sup>	mt
80.22 T	3 ~ 400V	H07RNF	4x1*	20
80.37 T	3 ~ 400V	H07RNF	4x1,5*	20

\* Free terminals

**Optional**

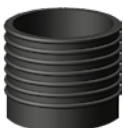

Output with hose connection

**Packaging dimension**

Type	X mm	Y mm	Z mm	Kg
KPM 80.22 T	350	690	270	52,5
KPM 80.37 T				58

*Vertical Outlet G4" - RPM 2850 2 poles*
**100.55-110**
*Picture for illustration purposes only*

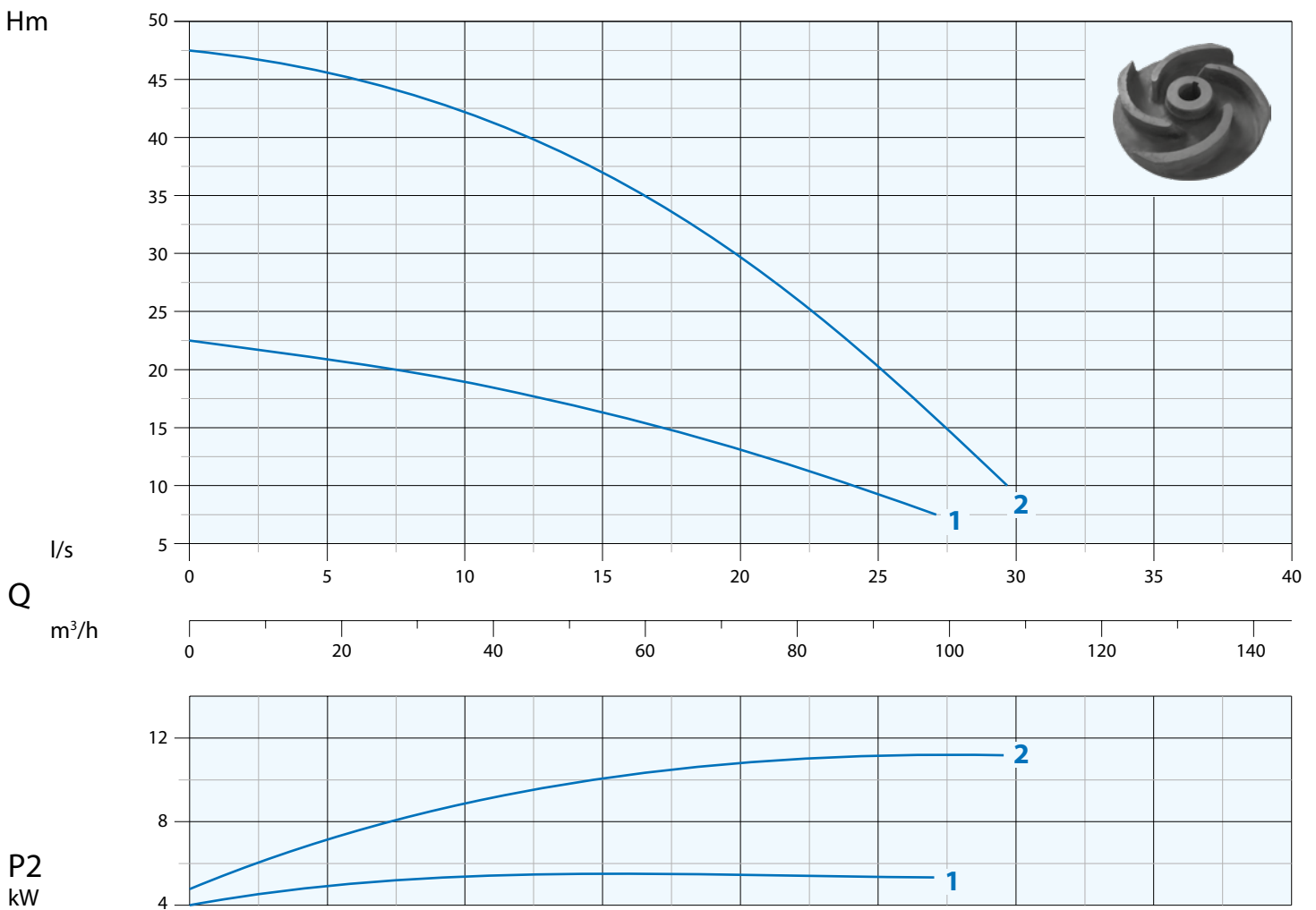
**Performance Curve**

N°	Type	l/s	2,5	5	7,5	10	12,5	15	20	25	30
			l/m	150	300	450	600	750	900	1200	1500
		m <sup>3</sup> /h	9	18	27	36	45	54	72	90	108
1	KPM 100.55 T	mt	21,5	21	20	19	17,5	16,5	13	9	
2	KPM 100.110 T		46	45,5	43,5	42,5	40	37	30	20	10

N°	Type	Delivery	Free Passage	kW		HP	R.P.M. 1/min	A	Hz
				P1	P2			3 Phase - 400V	
1	KPM 100.55 T	G4" male	Ø 11 mm	7,5	5,5	7,5	2850	12,4	50
2	KPM 100.110 T		Ø 15 mm	15	11	15		24,8	

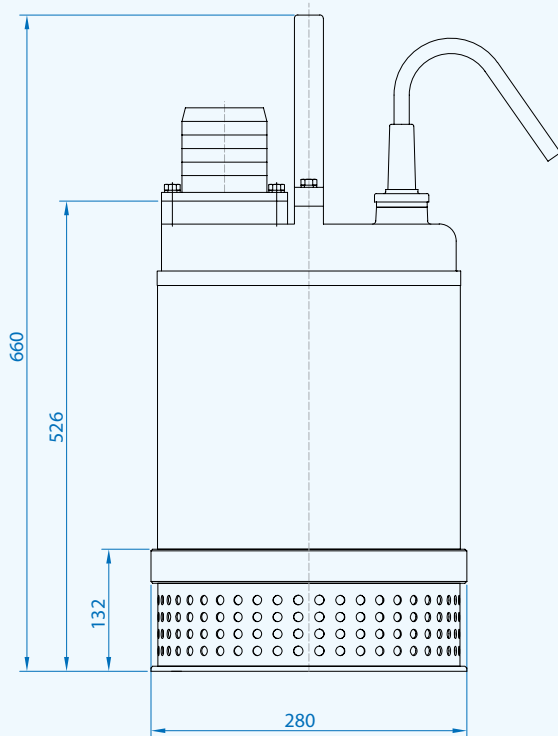
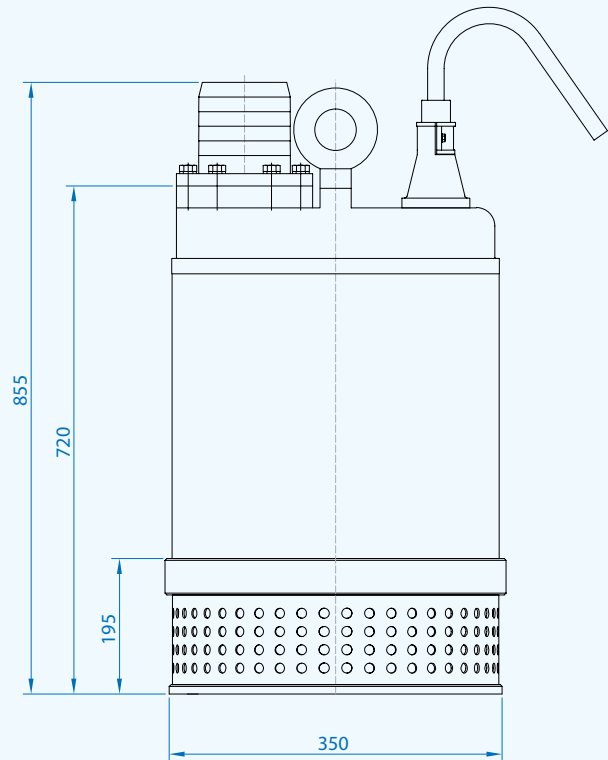
**KPM 100.55**

**KPM 100.110**

**Cables**

Pumps	Phases	Cable	Cable cross section mm <sup>2</sup>	mt
100.55 T	3 ~ 400V	H07RNF	4x2,5*	20
100.110 T	3 ~ 400V	H07RNF	4x4*	20

\* Free terminals

**Optional**

Output with hose connection

**Packaging dimension**

Type	X mm	Y mm	Z mm	Kg
KPM 100.55 T	360	780	360	60
KPM 100.110 T	460	1024	460	135

## Submersible mixer

Power:	<b>1.1 ÷ 2.5 kW</b>
--------	---------------------



### Designation

**DRX 200 - 42 / 110**

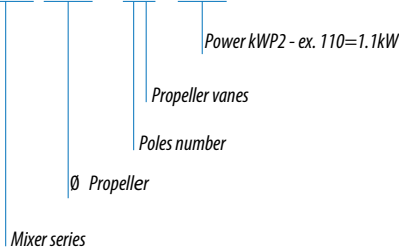

### Flow range

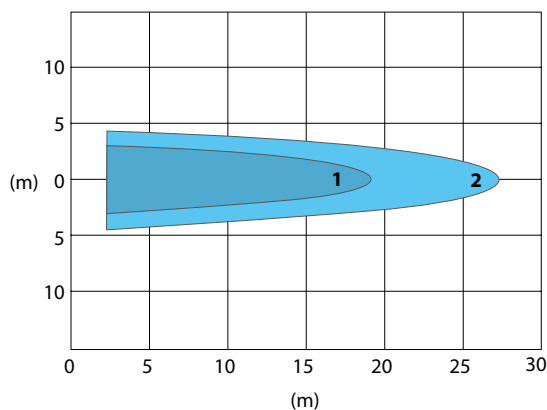

- 1 - DRX 200-42/110
- 2 - DRX 280-42/250

### Use

The submersible mixers of the DRX line have a wide range of application including homogenizing process in sewage treatment plant, water treatment, industrial and zootechnical applications.

Applications	Max permissible flow in m <sup>3</sup>
Denitrification	150
Nitrification	150
Treatment of phosphate	150
Crust prevention	variable according to the type of liquid
Ice prevention	variable according to the liquid
Cooling of basins	temperature
Coagulation	150
Chemical liquid mixing	variable according to the type of liquid
Storm water treatment	180
Sewerage treatment	25

### Construction features

Main components in cast iron EN GJL-250  
 One mechanical seal and one lip seal in oil bath guarantee a perfect functioning.  
 Mounting brackets in stainless steel AISI 416.

### Motors

- Asynchronous 4 pole motor squirrel cage rotor type.
- Thermal protection embedded in the winding to be connected to suitable control panel.
- Motor insulation: class F 155°
- Protection: IP 68
- Voltage: 230V/400V ± 5%
- Frequency: 50Hz ± 2%

### Cooling of the motor

The cooling of the motor is ensured by the liquid where the mixer is submerged

### Limits of use

- Max. permissible liquid temperature: 40°C pump fully submerged
- On request, special version to withstand liquid temperature up to 60°C with pump fully submerged, no S1 service
- Max immersion depth: 20 mt.
- Permissible Ph value: 6-10
- Max solid contents in the liquid: 10kg/m<sup>3</sup>
- Mixing capacity: 100-150 ml/g
- Mixing degree: 2.5

**List of components and materials**

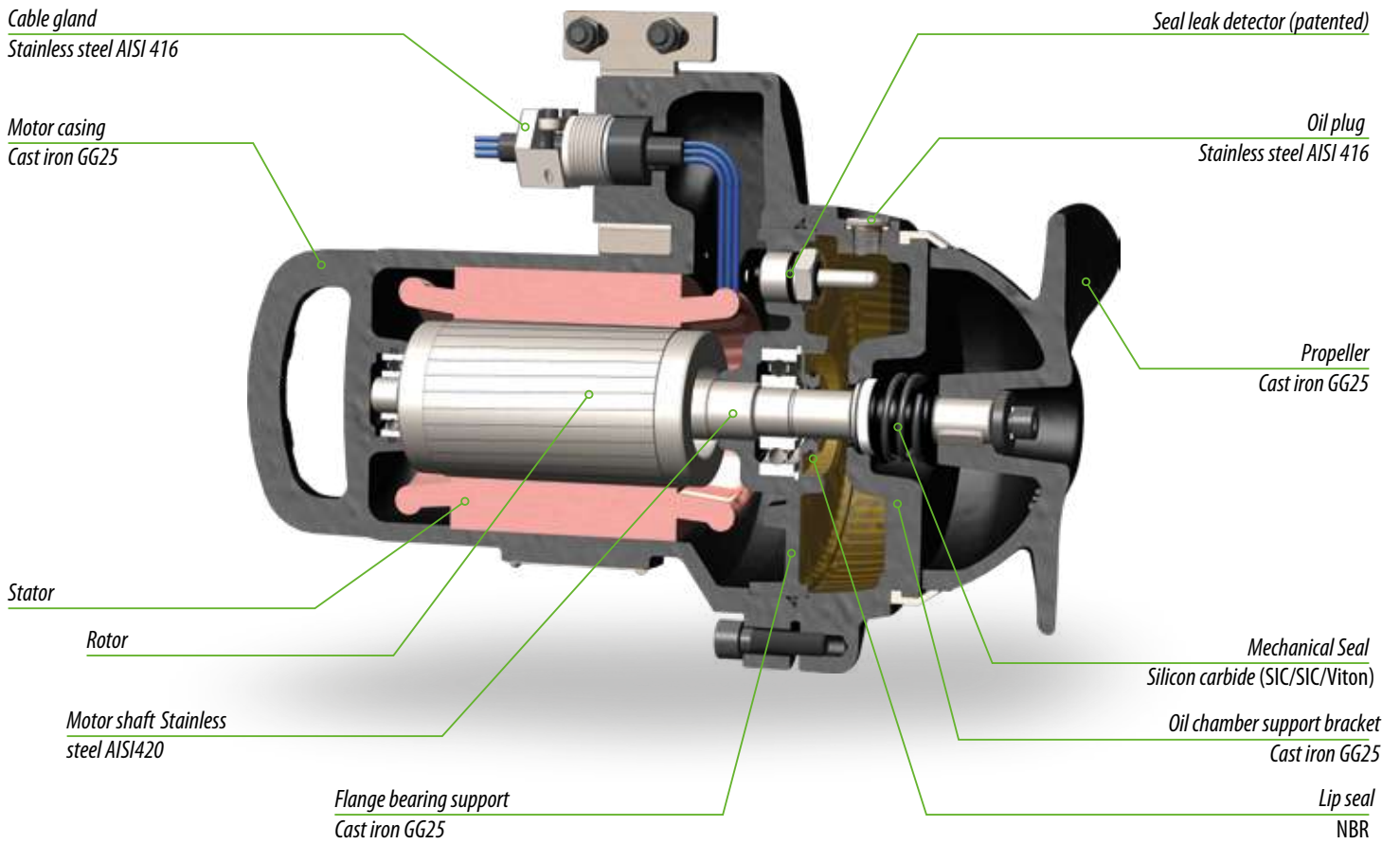

**Technology and Features**



**Propeller**  
2 blades propeller with inclination angle at 16°, designed to ensure the best efficiency and thrust.

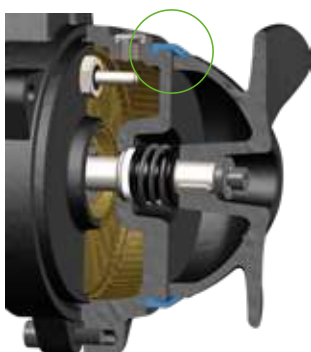

**Deflector ring**  
The special deflector ring prevents fibrous material and solids from entering in contact with the mechanical seal thus avoiding blockage problems.

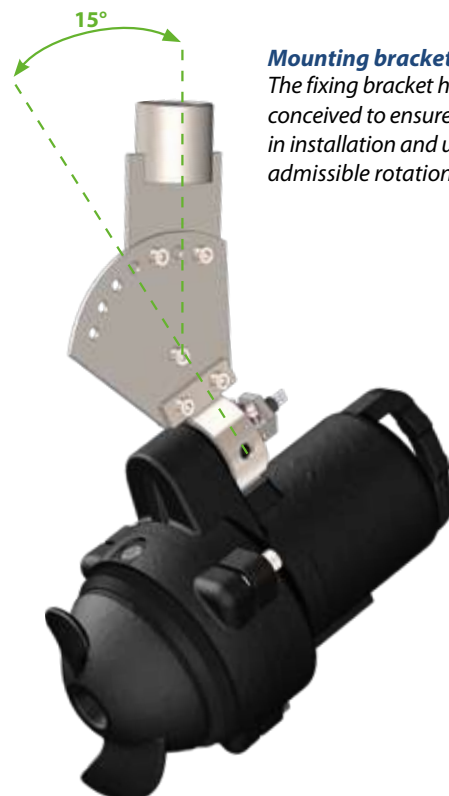

**Mounting bracket**  
The fixing bracket has been conceived to ensure high flexibility in installation and use. Maximum admissible rotation +/- 15°.

## Specification

Type	Ø Propeller	RPM	kW		A	Hz	N
			P1	P2	400V		Spinta - Thrust
<b>DRX 200-42/110</b>	200 - Angle 16°	1450	1,6	1,1	2,8	50	200
<b>DRX 280-42/250</b>	280 - Angle 16°	1450	3,3	2,5	5,6		350

Cable: H07RNF8 4x1.5+3x0.50 Ø16.5 Free terminals

## Dimensions

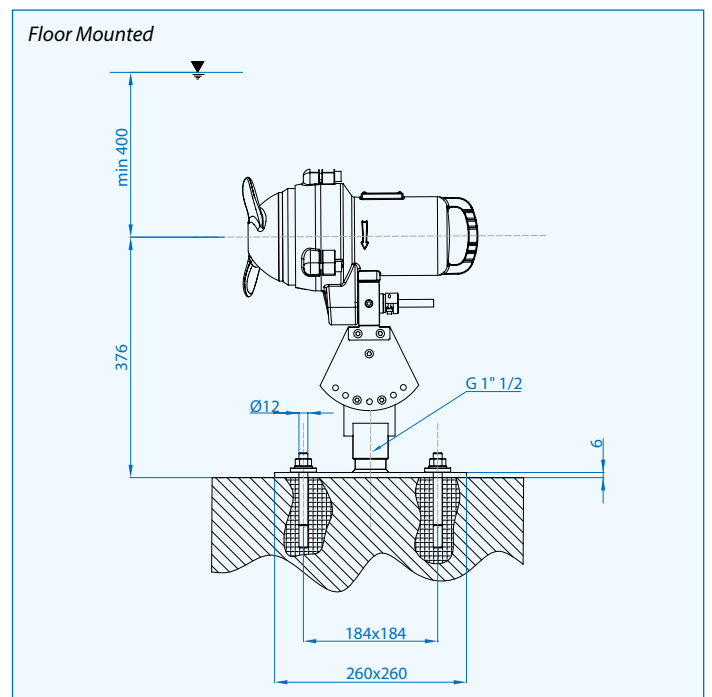
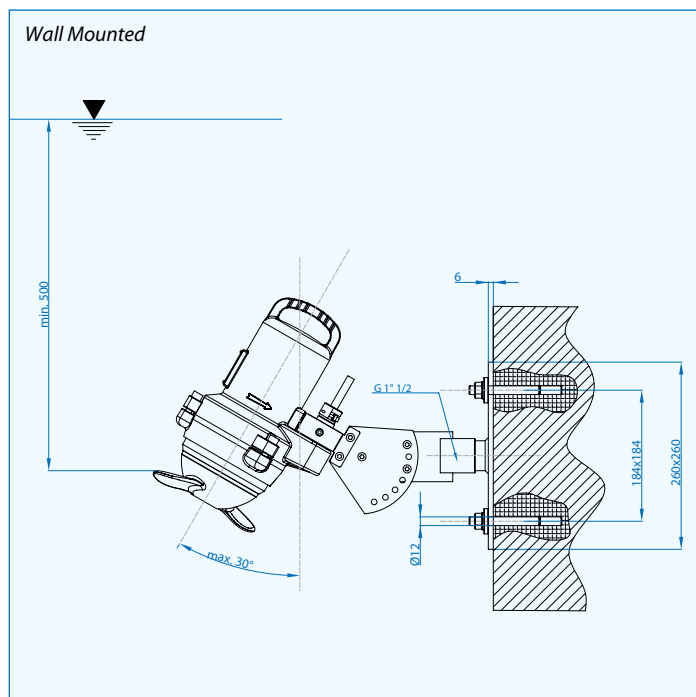
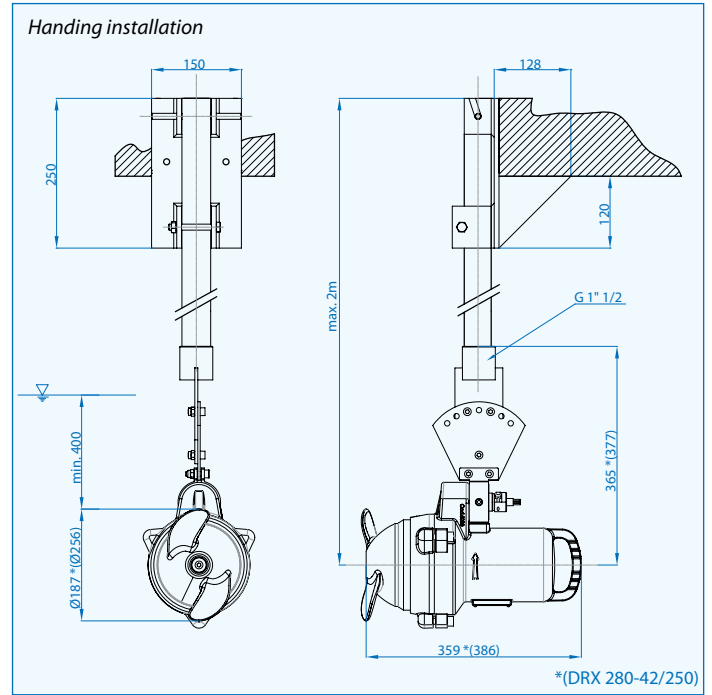
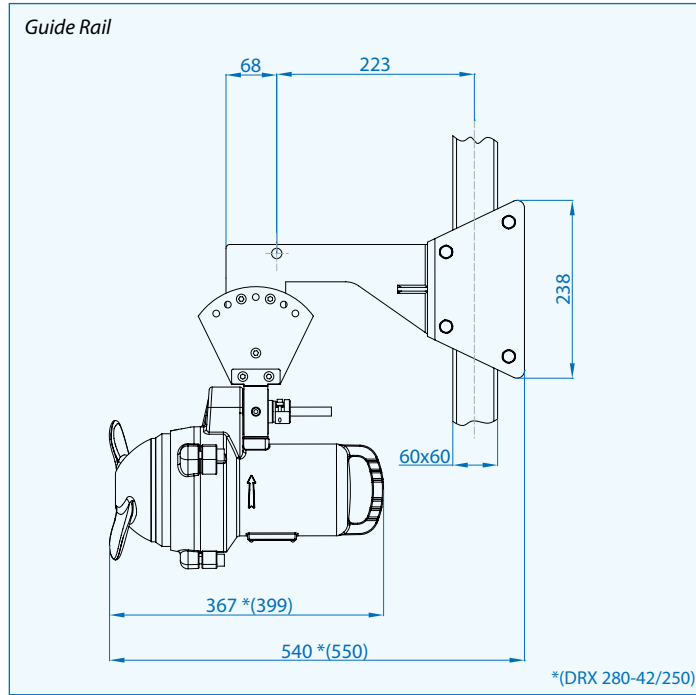

## Packaging dimension

Type	X mm	Y mm	Z mm	Kg
<b>DRX 200-42/110</b>	300	415	240	26
<b>DRX 280-42/250</b>	300	415	240	35

**Example of installation**

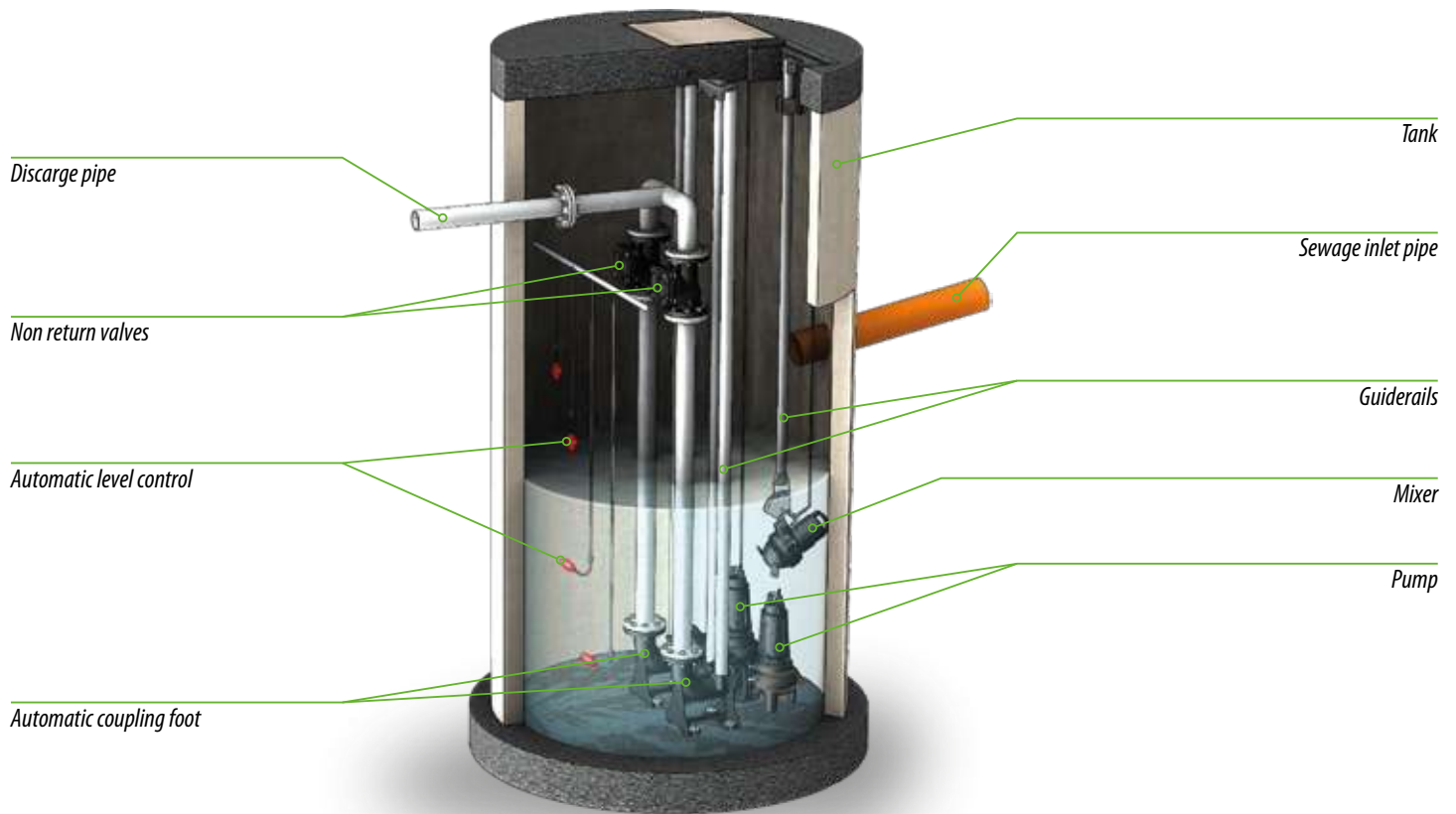

**Configuration of installation**

**Round basin**

Max dimensions:  
 DRX 200-42/110 Ø3.5 m  
 DRX 280-42/250 Ø5 m

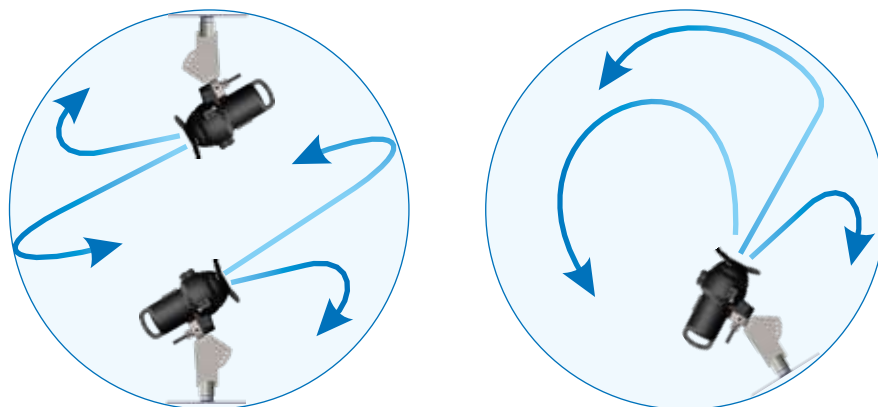

**Rectangular basin**

Max dimensions:  
 DRX 200-42/110 3x5m  
 DRX 280-42/250 4x6m

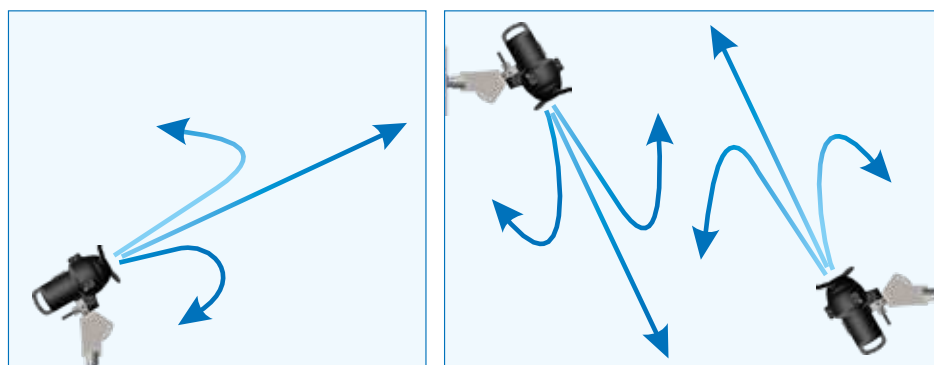



## Accessories

### Installation with guide rail

**Main specifications**

- Fixed and adjustable installation with mast
- Robust and reliable installation
- All components are made of stainless steel

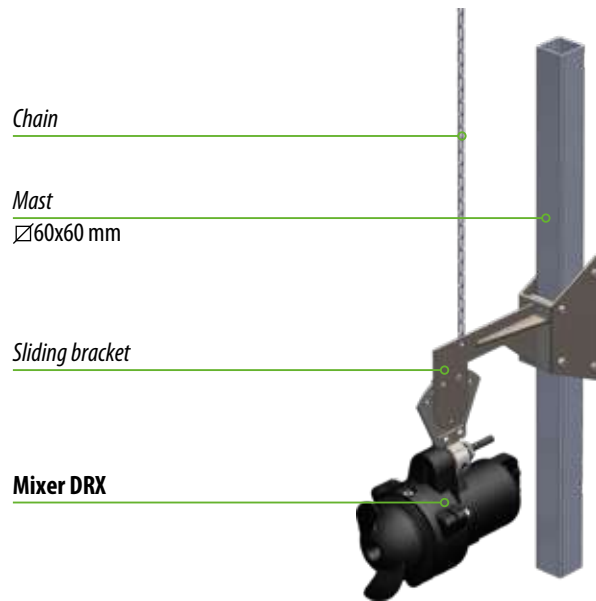

### Handing installation

**Main specifications**

- Adjustable equipment with mast
- Quickly installation operation
- All components are made of stainless steel



### Wall/floor mounted

**Main specifications**

- Adjustable installation on vertical and horizontal surfaces
- Flexibly installation
- All component are made of stainless steel

