



Submersible Drainage Sewage Pump

Made in Taiwan



Catalogue 50 Hz

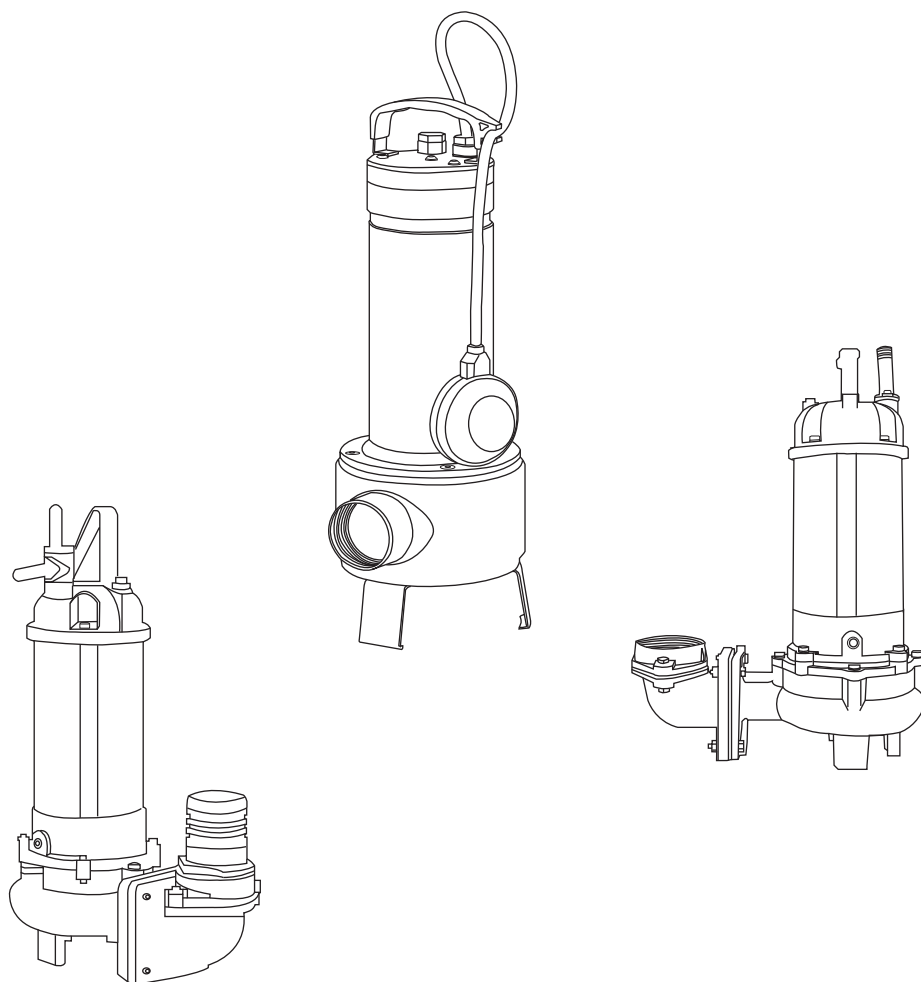

page	Performance curves / Technical data	
4	XD	Submersible Drainage Pumps
6	XV	Submersible Vortex Sewage Pumps
8	HM	Submersible Vortex Sewage Pumps
10	SC	Submersible Cutter Sewage Pumps
12	SA	Submersible Agitator Sewage Pumps
14	Guide Rail System	

General Data/Material



Operating Conditions	Applications	Emptying of septic tanks and residential sumps.
	Fluid Temperature	0 to 50°C
Motor	Type	Dry Type
	Pole	2-pole
	Insulation	Class F
	Protection	IP68
Pump	Protection Device	Thermal Protector (single phase)
	Impeller	Open Impeller
	Shaft Seal/Material	Double seals
	Bearing	Double-shielded Ball Bearing

Component	Material
Cable	H07RN-F
Handle	AISI 304+Nylon
Motor Cover	AISI 304
Motor Casing	AISI 304
Fixing Ring	AISI 304
Pump Body	AISI 304
Mechanical seal	Sic/Sic/NBR
Impeller	AISI 304
Key	AISI 304
Pump Casing	AISI 304
Oil Seal	NBR
Shaft	AISI 304
V-type Axial Oil Seal	NBR
Suction flange	AISI 304

Characteristic curves N= 2900 rpm

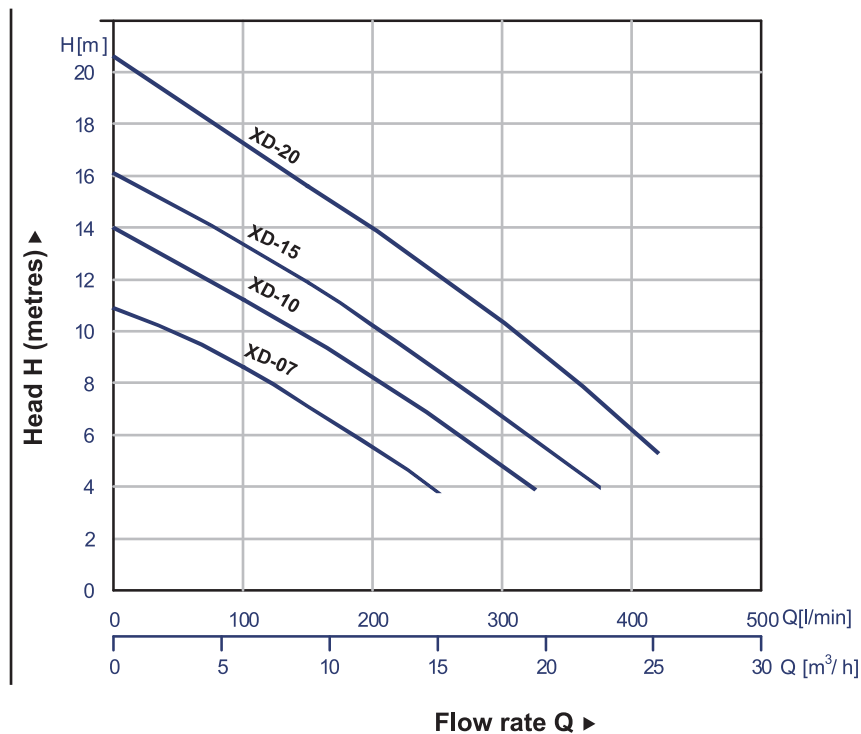

Specifications

Model	Power HP (kW)	Discharge inch	Phase (Voltage)	Standard		Max		Solid Passage mm	Cable M
				Head M	Capacity LPM	Head M	Capacity LPM		
XD-07	0.75(0.55)	RP 1 1/2"	1 ϕ 220V-240V / 3 ϕ 220V-240V / 380V-415V	8.6	100	10.9	250	8	10
XD-10	1.0(0.75)	RP 1 1/2"	1 ϕ 220V-240V / 3 ϕ 220V-240V / 380V-415V	11.2	100	14	325	8	10
XD-15	1.5(1.1)	RP 1 1/2"	1 ϕ 220V-240V / 3 ϕ 220V-240V / 380V-415V	11.9	150	16.1	375	8	10
XD-20	2.0(1.5)	RP 1 1/2"	3 ϕ 220V-240V / 380V-415V	15.6	150	20.6	420	8	10

Auto Float Switches are available in Single-phase

Dimensions and Weights

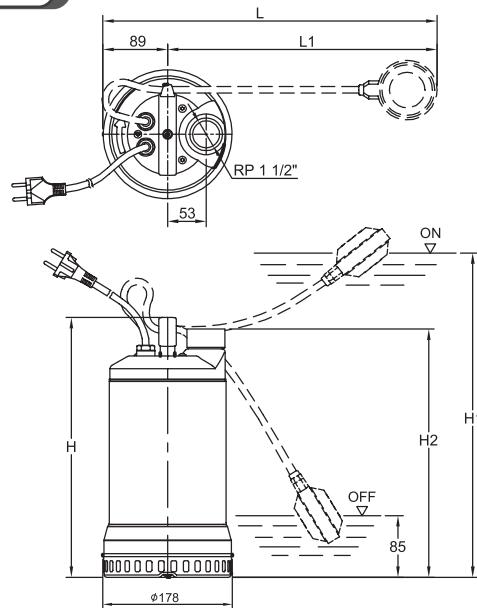

SINGLE-PHASE

Model	Dimension (mm)					
	H	H1	H2	L	L1	N.W. kg
XD-07	357	437	341	459	370	12
XD-10	407	497	391	514	425	15
XD-15	407	497	391	514	425	17

THREE-PHASE

Model	Dimension (mm)		
	H	H2	N.W. kg
XD-07	357	341	12
XD-10	357	341	12
XD-15	407	391	15
XD-20	407	391	17

General Data/Material



Operating Conditions	Applications	Emptying of septic tanks and residential sumps.
	Fluid Temperature	0 to 35°C
Motor	Type	Dry Type
	Pole	2-pole
	Insulation	Class F
	Protection	IP68
	Protection Device	Thermal Protector (single phase)
Pump	Impeller	Vortex Impeller
	Shaft Seal/Material	Double seals
	Bearing	Double-shielded Ball Bearing

Component	Material
Cable	H07RN-F
Handle	AISI 304+Nylon
Motor Cover	AISI 304
Motor Casing	AISI 304
Fixing Ring	AISI 304
Pump Body	AISI 304
Mechanical seal	Sic/Sic/NBR
Impeller	AISI 304
Key	AISI 304
Pump Casing	AISI 304
Oil Seal	NBR
Shaft	AISI 304
V-type Axial Oil Seal	NBR
Suction flange	AISI 304

Characteristic curves N= 2900 rpm

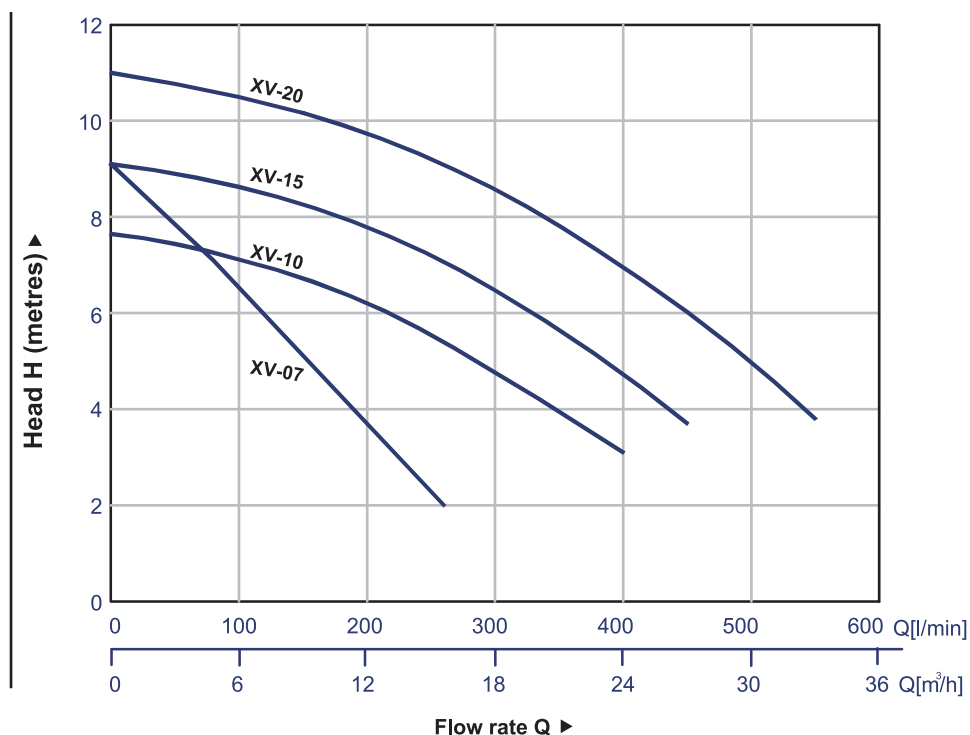

Specifications

Model	Power HP (kW)	Discharge inch	Phase (Voltage)	Standard		Max		Solid Passage mm	Cable M
				Head M	Capacity LPM	Head M	Capacity LPM		
XV-07	0.75(0.55)	RP 1 1/2"	1 ϕ 220V-240V / 3 ϕ 220V-240V / 380V-415V	7.1	80	9.1	260	35	5
XV-10	1.0(0.75)	RP 2"	1 ϕ 220V-240V / 3 ϕ 220V-240V / 380V-415V	7.1	100	7.7	400	50	10
XV-15	1.5(1.1)	RP 2"	1 ϕ 220V-240V / 3 ϕ 220V-240V / 380V-415V	8.6	100	9.1	450	50	10
XV-20	2.0(1.5)	RP 2"	3 ϕ 220V-240V / 380V-415V	10.2	150	11	550	50	10

Auto Float Switches are available in Single-phase

Dimensions and Weights

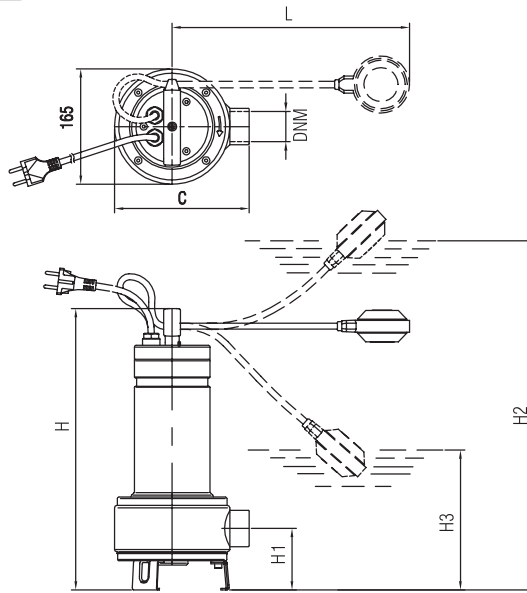

SINGLE-PHASE

Model	Dimension (mm)							
	H	H1	H2	H3	L	C	DNM	N.W. kg
XV-07	403	88	483	185	350	193	RP1 1/2"	11
XV-10	486	111.5	566	268	350	198	RP 2"	14
XV-15	486	111.5	566	268	350	198	RP 2"	15

THREE-PHASE

Model	Dimension (mm)				
	H	H1	C	DNM	N.W. kg
XV-07	403	88	193	RP1 1/2"	11
XV-10	436	111.5	198	RP 2"	12
XV-15	486	111.5	198	RP 2"	14
XV-20	486	111.5	198	RP 2"	15



Model code

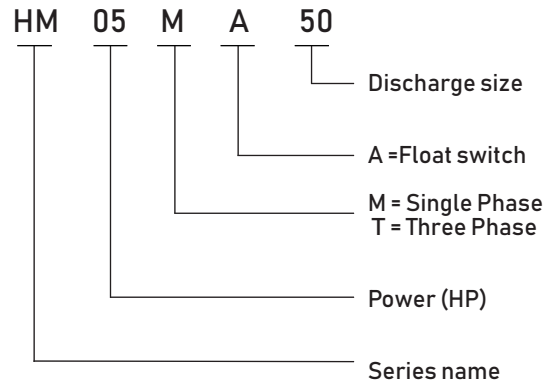

Applications

- Basement water removal
- Waste water drainage
- Water transfer
- Sump / effluent handling
- Dewatering
- Fish pond & fountain circulation
- Sewage handling
- Factory waste water handling

Motor Data

- Motor Type : 2 POLE , dry type
- Frequency : 50Hz
- Nominal Speed : 2850 rpm
- Insulation Class : F class (155°C)
- Enclosure Protection Class : IP 68
- Protection Device :
Thermal Protector (Single phase)
Overload Protector (Three phase)

Pump Data

- Impeller : Vortex Impeller
- Shaft Seal / Mechanical :
Double Mechanical Seal
- Bearing :
Double-shielded Ball Bearing

Operation Conditions

- Fluid Temperature: 0 to 40°C

Material

No.	Component	Material
1	Cable	H07RN-F or VCT
2	Handle	Nylon6+30GF
3	Motor cover	ADC-12
4	Bearing cap	SECC
5	Motor frame	ADC-12
6	M.Seal Bracket	FC200
7	Cable Base	Nylon6+30GF
8	Motor Shaft	AISI410
9	Mechanical seal	CA / CE, SIC/SIC
10	Oil Seal	NBR70
11	Impeller	FC25
12	Pump casing	FC200
13	Flange	FC200
14	Strainer	PVC

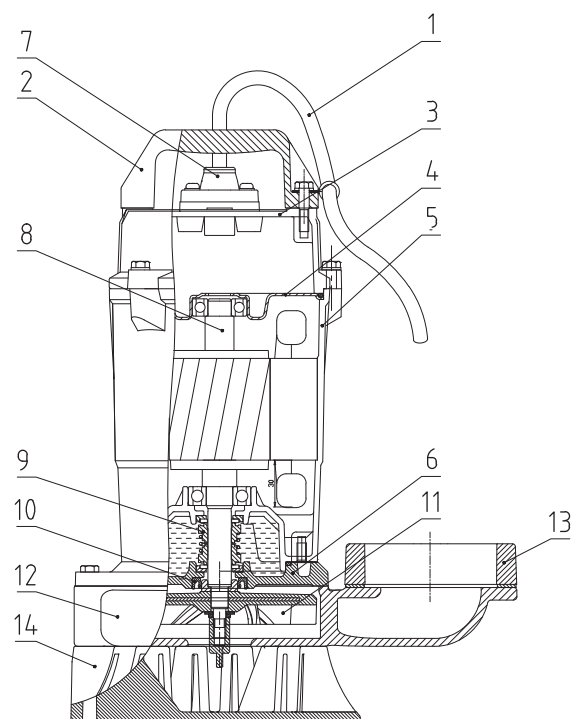

Performance curves

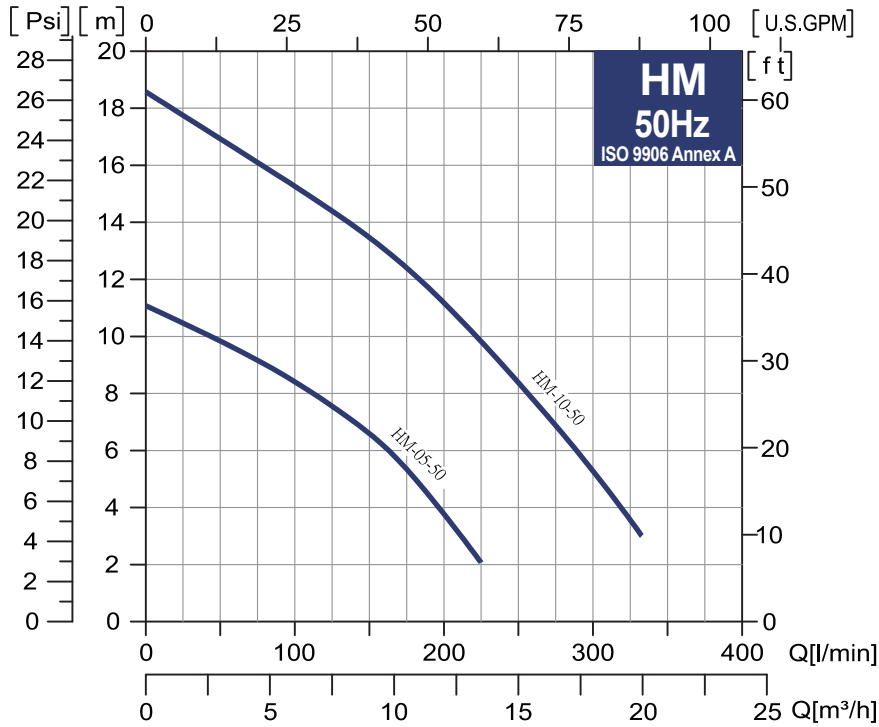

Q=Capacity				
l/min	0	100	200	300
m³/h	0	6	12	18
H=Total manometric head				
HM 05M50	11.0	8.6	3.6	—
HM 10M50	18.6	15.3	11.6	5.7

Cable
M

Technical data

Single phase

Model	Power		Nominal Current [A]		Capacitort	Connection	Discharge [inch]	Head		Flow		Solid Passage [mm]	Cable [M]	N.W. [kg]
	HP	kW	220 - 240V	220-240V [uF] [V]				Rated [M]	Max. [M]	Rated [L/min]	Max. [L/min]			
HM-05M50 HM-05MA50	0.5	0.37	2.7 - 2.5	12 450	flange	2"	7	11.0	140	225	10	10	12.9	
HM-10M50 HM-10MA50	1	0.75	5.8 - 5.4	20 450	flange	2"	10	18.6	230	335	10	10	15.1	
HM-10M80 HM-10MA80	1	0.75	5.8 - 5.4	20 450	flange	3"	10	18.6	230	335	10	10	15.1	

A = Auto Float Switch

Three phase

Model	Power		Nominal Current [A]		Connection	Discharge [inch]	Head		Flow		Solid Passage [mm]	Cable [M]	N.W. [kg]
	HP	kW	220 - 240V	380 - 415V			Rated [M]	Max. [M]	Rated [L/min]	Max. [L/min]			
HM-05T50	0.5	0.37	2.2 - 2.0	1.3 - 1.2	flange	2"	7	11.0	140	225	35	10	11.9
HM-10T50	1	0.75	3.6 - 3.4	2.1 - 1.9	flange	2"	10	18.6	230	335	35	10	14.1
HM-10T80	1	0.75	3.6 - 3.4	2.1 - 1.9	flange	3"	10	18.6	230	335	35	10	14.1

Dimensions and weights

Model	phase	Discharge [mm]									
		A	A1	A2	D	H	H1	H2	H3	H4	H5
HM-05-50	1 3	254	95	120	180	365	264	90	110	115	535
HM-10-50(80)	1 3	285	95	135	180	380	279	90	116	130	550

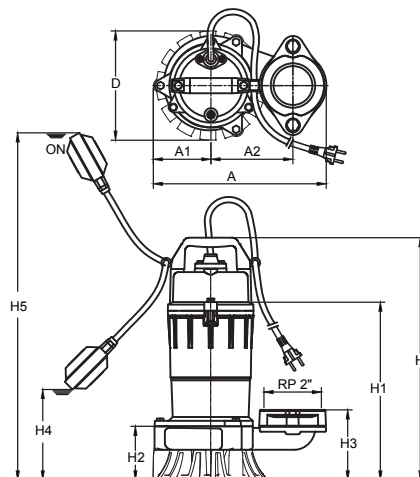

General Data/Material



Operating Conditions	Applications	Waste water for domestic and civil purposes
	Fluid Temperature	0 to 40 °C
Motor	Type	Dry Type
	Pole	2-pole
	Insulation	Class F
	Protection	IP68
	Protection Device	Thermal Protector
Pump	Impeller	Semi-Open Impeller with Tungstein Carbide Edge
	Shaft Seal/Material	Double Mechanical Seal and one oil Seal
	Bearing	Double-shielded Ball Bearing

Component	Material
Cable	H07RN-F
Handle	Nylon SS 41
Motor Cover	Cast Iron GJL 200
Seal Housing	Cast Iron GJL 201
Bracket	Cast Iron GJL 202
Oil Chamber	Cast Iron GJL 203
Pump Casing	Cast Iron GJL 204
Impeller	Cast Iron GJS 450
Mechanical seal: Upper	CA/CE
Lower	Sic/Sic
Oil Seal	NBR
Cutter edge	Tungsten
Shaft	AISI 410
Motor Housing	AISI 304

Characteristic curves N=2900 rpm

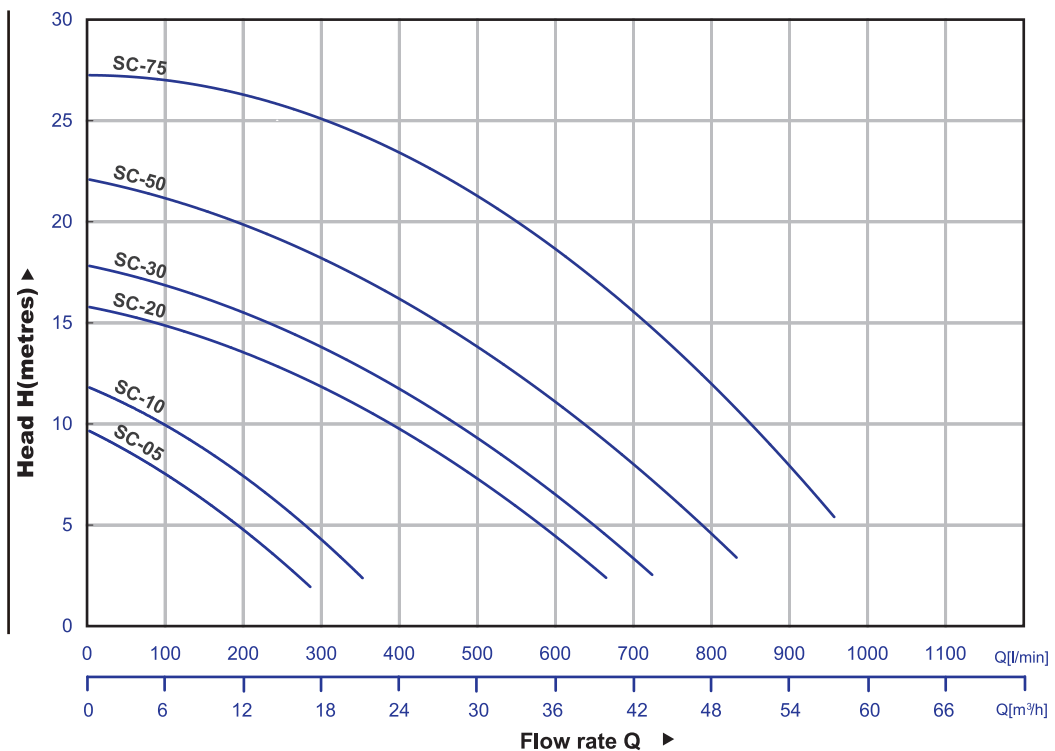

Specifications

Model	Power HP (kW)	Discharge inch	Phase	Standard		Max		Solid Passage mm	N.W. kg	Cable M
				Head M	Capacity LPM	Head M	Capacity LPM			
SC-05-50	1/2 (0.37)	2"	1φ/3φ	6	150	8	300	22	13.5	10
SC-10-50	1 (0.75)	2"	1φ/3φ	8	180	12	400	22	18.5	10
SC-20-50(80)	2 (1.5)	2"/3"	1φ/3φ	10	400	16	700	22	34	10
SC-30-50(80)	3 (2.2)	2"/3"	3φ	12	400	18	750	22	35	10
SC-50-80(100)	5 (3.7)	3"/4"	3φ	15	450	22	900	28	57	10
SC-75-80(100)	7.5 (5.5)	3"/4"	3φ	20	550	28	1000	28	63	10

SC-05-50: Threaded Flange Type

SC-10-50: Threaded Flange type or Elbow Type

SC-20-50(80)~SC-30-50(80): Elbow Type (2" or 3")

SC-50-80(100)~SC-75-80(100): Elbow Type (3" or 4")
Auto Float Switches are available in Single-phase

Dimensions and Weights

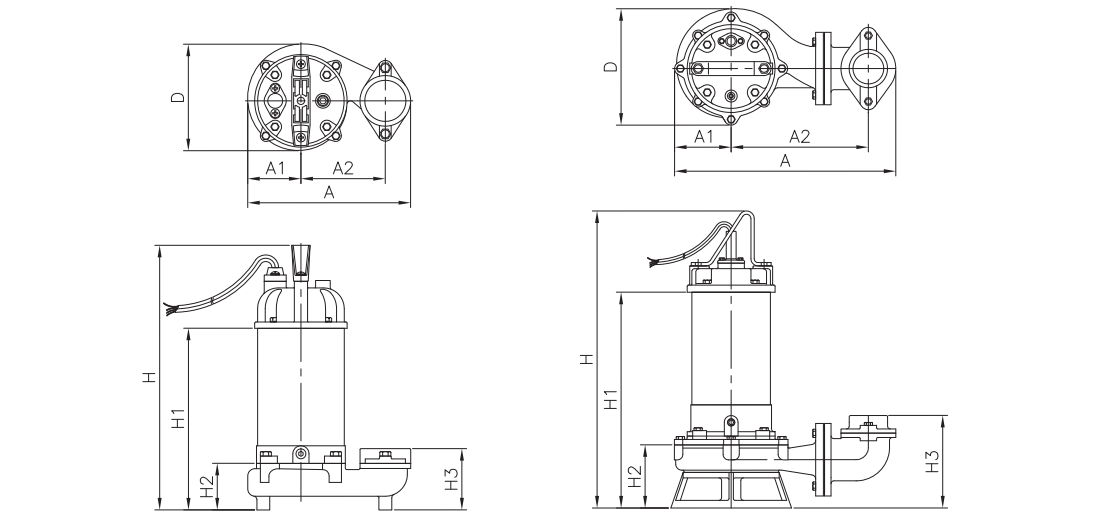

Model	Dimension (mm)								
	A	A1	A2	D	H	H1	H2	H3	
SC-05-50	222	73	115	145	372	259	75	95	
SC-10-50	Flange	222	73	115	149	427	303	75	95
	Elbow	336	93	193	188	454	330	103	159
SC-20-50(80)	1Ø	403	103	250	212	561	413	115	169
	3Ø	403	103	250	212	541	393	115	169
SC-30-50(80)	403	103	250	212	561	413	115	169	
SC-50-80(100)	463	110	260	227	610	445	137	220	
SC-75-80(100)	463	110	260	227	650	485	137	220	

General Data/Material



Operating Conditions	Applications	Waste water for domestic and civil purposes
	Fluid Temperature	0 to 40 °C
Motor	Type	Dry Type
	Pole	2-pole
	Insulation	Class F
	Protection	IP68
Pump	Protection Device	Thermal Protector (single phase) Overload Protector (three phase)
	Impeller	Vortex Impeller
	Shaft Seal/Material	Double Mechanical Seal and one oil Seal
	Bearing	Double-shielded Ball Bearing

Component	Material
Cable	H07RN-F
Handle	Nylon SS 41
Motor Cover	Cast Iron GJL 200
Seal Housing	Cast Iron GJL 200
Bracket	Cast Iron GJL 200
Oil Chamber	Cast Iron GJL 200
Pump Casing	Cast Iron GJL 200
Impeller	Cast Iron GJL 200
Agitator	AISI 316
Mechanical seal: Upper	CA/CE
Lower	Sic/Sic
Oil Seal	NBR
Shaft	AISI 410
Motor Housing	AISI 304

Characteristic curves N=2900 rpm

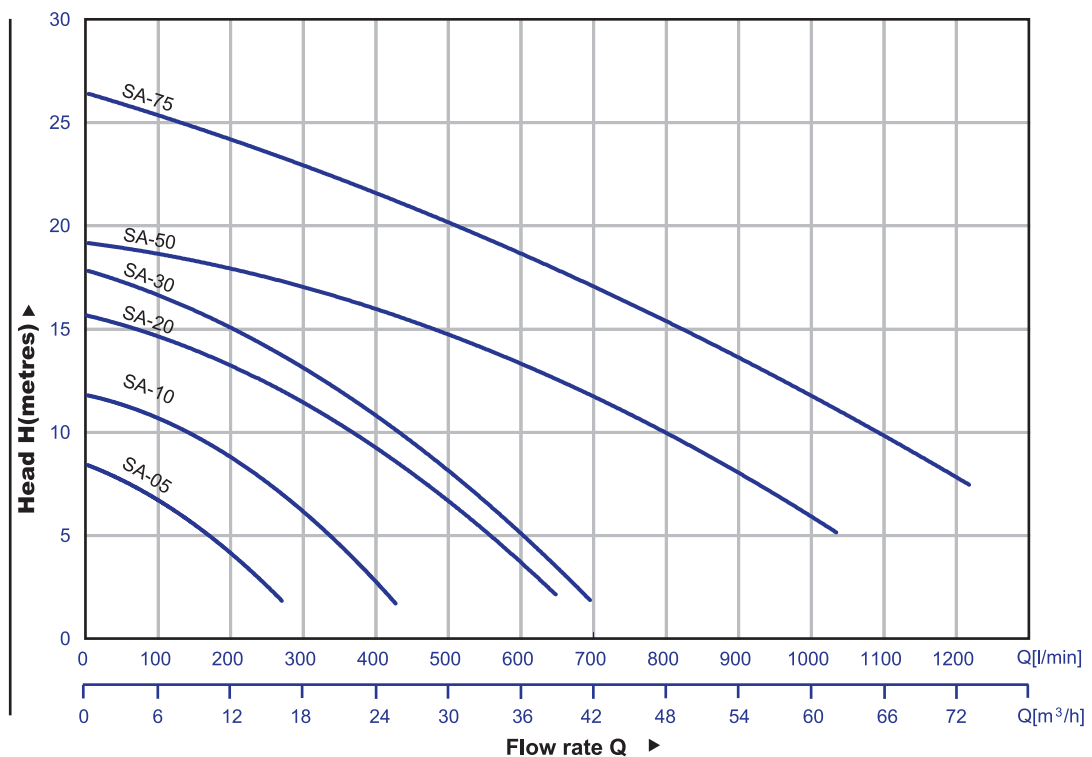

Specifications

Model	Power HP (kW)	Discharge inch	Phase	Standard		Max		Solid Passage mm	N.W. kg	Cable M
				Head M	Capacity LPM	Head M	Capacity LPM			
SA-05-50	1/2 (0.37)	2"	1φ/3φ	6	130	8	300	20	13.5	10
SA-10-50	1 (0.75)	2"	1φ/3φ	8	180	12	400	20	18.5	10
SA-20-50(80)	2 (1.5)	2"/3"	1φ/3φ	10	350	16	650	20	34	10
SA-30-50(80)	3 (2.2)	2"/3"	3φ	11	400	18	700	20	35	10
SA-50-80(100)	5 (3.7)	3"/4"	3φ	15	500	19	1000	35	57	10
SA-75-80(100)	7.5 (5.5)	3"/4"	3φ	20	600	27	1100	35	63	10

SA-05-50: Threaded Flange Type

SA-10-50: Threaded Flange type or Elbow Type

SA-20-50(80)~SA-30-50(80): Elbow Type (2" or 3")

SA-50-80(100)~SA-75-80(100): Elbow Type (3" or 4")
Auto Float Switches are available in Single-phase

Dimensions and Weights

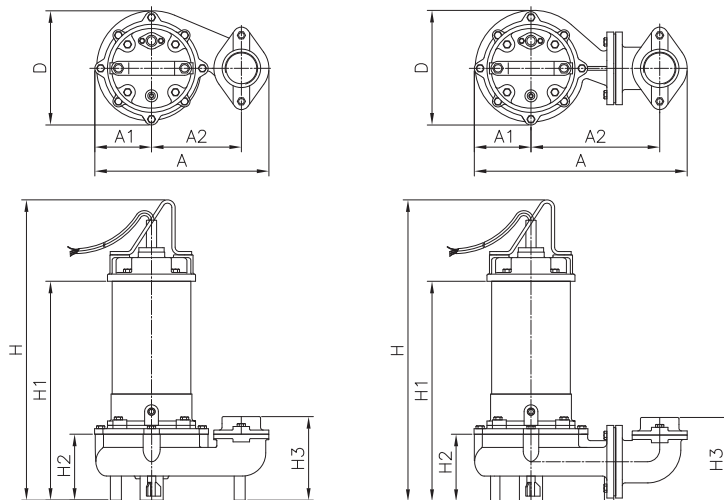

Model	Dimension (mm)							
	A	A1	A2	D	H	H1	H2	H3
SA-05-50	222	73	115	145	410	297	113	133
SA-10-50	222	73	115	149	464	340	113	133
SA-20-50(80)	387	103	234	208	548	400	122	153
SA-30-50(80)	387	103	234	208	568	420	122	153
SA-50-80(100)	459	110	256	227	638	471	160	220
SA-75-80(100)	459	110	256	227	678	511	160	220

Selection Table

Model	Connections	Guide Rail Models				
		TS-50	TM-50(80)	TL-80(100)	STM-50(80)	STL-80(100)
		Materials				
		FC200	FC200	FC200	SUS316	SUS316
SD-03-50	elbow		▲			
SD-05-50	thread			NOT AVAILABLE		
SD-05-50	elbow		▲			
SD-10-50	thread			NOT AVAILABLE		
SD-10-50	elbow		●			
SD-20-5(80)	elbow		●			
SD-30-50(80)	elbow		●			
SD-50-80(100)	elbow			●		
SD-75-80(100)	elbow			●		
SV-3-50	thread/flange	●				
SV-05-50	thread/flange	●				
SV-05-50	elbow		▲			
SV-10-50	thread/flange	●				
SV-10-50	elbow		▲			
SV-20-50(80)	elbow		●			
SV-30-50(80)	elbow		●			
SV-50-80(100)	elbow			●		
SV-75-80(100)	elbow			●		
SVN-05-50	thread/flange			NOT AVAILABLE		
SVN-05-50	elbow				▲	
SVN-10-50	thread/flange			NOT AVAILABLE		
SVN-10-50	elbow				▲	
SVN-20-50(80)	elbow				●	
SVN-30-50(80)	elbow				●	
SVN-50-80(100)	elbow					●
SVN-75-80(100)	elbow					●
SC-05-50	thread/flange	●				
SC-05-50	elbow		▲			
SC-10-50	thread/flange	●				
SC-10-50	elbow		▲			
SC-20-50(80)	elbow		●			
SC-30-50(80)	elbow		●			
SC-50-80(100)	elbow			●		
SC-75-80(100)	elbow			●		
SA-05-50	thread/flange	●				
SA-05-50	elbow		▲			
SA-10-50	thread/flange	●				
SA-10-50	elbow		▲			
SA-20-50(80)	elbow		●			
SA-30-50(80)	elbow		●			
SA-50-80(100)	elbow			●		
SA-75-80(100)	elbow			●		



TS



TM



TL

TS Model: Angle type, 2" Discharge

TM Model: Tube type, available 2" or 3" Discharge

TL Model: Tube type, available 3" or 4" Discharge

▲ PUMPS WITH NON-STANDARD CONNECTIONS. IF TM-Tube Type Guide Rail to be used. Consult STAIRS.

TS

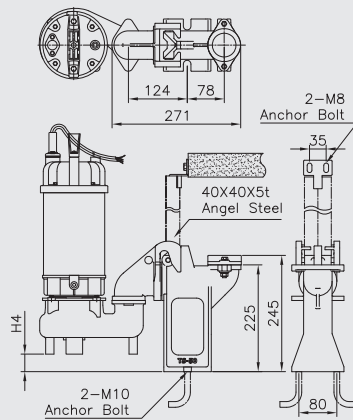

TS-50 Guide Rail			
Model	Output		Dimensions
	HP	kW	H4(mm)
SV-03-50	1/3	0.25	37
SV-05-50	1/2	0.37	37
SV-10-50	1	0.75	37
SA-05-50	1/2	0.37	37
SA-10-50	1	0.75	37
SC-05-50	1/2	0.37	75
SC-10-50	1	0.75	75
HM-05-50	1/2	0.37	65

TM

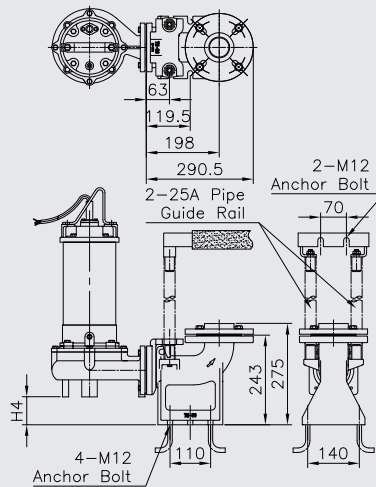

TM-50(80) Guide Rail			
Model	Output		Dimensions
	HP	kW	H4(mm)
SV-20-50/80	2	1.5	76
SV-30-50/80	3	2.2	76
SA-20-50/80	2	1.5	76
SA-30-50/80	3	2.2	76
SD-03-50	1/3	0.25	78
SD-05-50	1/2	0.37	78
SD-10-50	1	0.75	78
SD-20-50/80	2	1.5	65
SN-30-50/80	3	2.2	65
SC-20-50/80	2	1.5	60
SC-30-50/80	3	2.2	60
SVN-05-50	1/2	0.37	76
SVN-10-50	1	0.75	76
SVN-20-50/80	2	1.5	76
SVN-30-50/80	3	2.2	76

TL

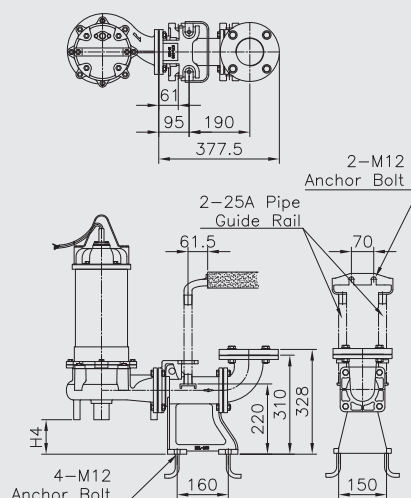

TL-80(100) Guide Rail			
Model	Output		Dimensions
	HP	kW	H4(mm)
SV-50-80/100	5	3.7	110
SV-75-80/100	7.5	5.5	110
SA-50-80/100	5	3.7	110
SA-75-80/100	7.5	5.5	110
SD-50-80/100	5	3.7	113
SD-75-80/100	7.5	5.5	113
SC-50-80/100	5	3.7	108
SC-75-80/100	7.5	5.5	108
SVN-50-80/100	5	3.7	108
SVN-75-80/100	7.5	5.5	108



www.sistema-pumps.com