



Submersible Drainage Pump

Made in Taiwan



Catalogue 60 Hz

Model code

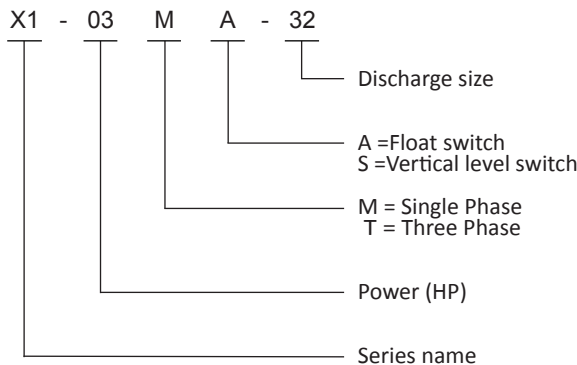

Feature

Stainless Steel Series electric submersible drainage pumps
 Compact design with Top Discharge Outlet reduces space usage for installation in small manholes, for use in domestic, installations and small featured works.

Two different types of lever sensors:

- Mechanical activated float switch with cable extender (A)
- Vertical Mechanical activated Float Switch with casement (S)

Top discharged cools and removes heat from the motor through the outlet. It allows these pumps to be used even when only partially submerged. Every model undergoes hydrostatic testing for leakage from the casing and mechanical seals.

Application

- Domestic drainage
- Grey water drainage.
- Koi pond
- Light waste water discharge.
- Hydro-sanitary
- Emergencies flooding pumping in homes
- Fountain and landscape
- Drainage pumping.
- Livestocks

Motor

- Motor Type: 2 POLE, dry type
- Frequency: 60Hz
- Insulation Class: F class (155°C)
- Nominal Speed: 3450 rpm

Operation Conditions

- Liquid Temperature: up to 50°C (122°F)
- MAX.depth: 5M

Pump

- Enclosure Protection Class: IP 68
- Protector: thermal protection, built-in (single phase)
- Insulation Class: F class (155°C)
- Bearing: double sealed with steel cage
- Mechanical seal: unbalance single mechanical seal bath in oil with spring type oil seal

No.	Component	Material
1	Cable	H05RN-F
2	Float switch	Plastic
3	Handle	NY66+G30
4	Motor cover	AISI 304
5	Motor housing	AISI 304
6	Oil Seal	NBR
7	Mechanical seal	Carbon Graphite Ceramic / NBR/ 304
8	Shaft	AISI 410
9	Pump housing	AISI 304
10	Impeller	AISI 304
11	Pump casing	AISI 304
12	Strainer	AISI 304
13	Spring washer	AISI 304
14	Hex Domed Nuts	AISI 304

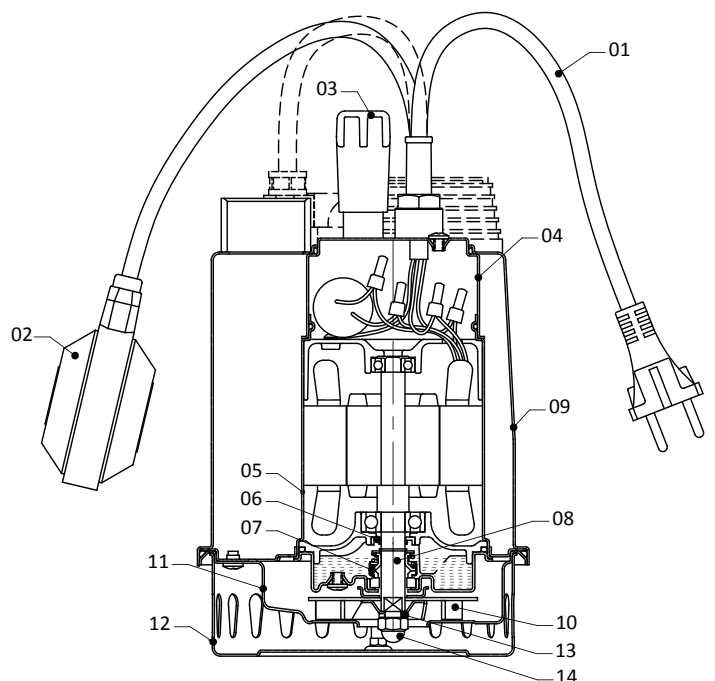

Dimension

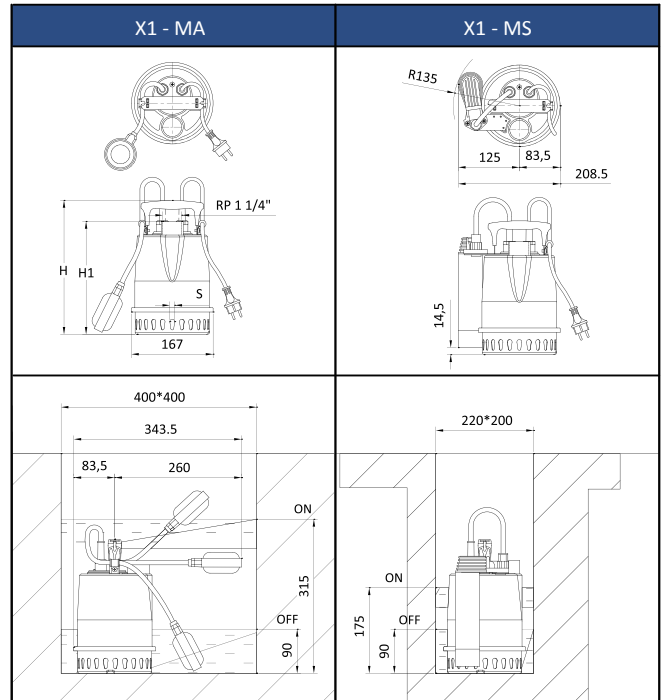
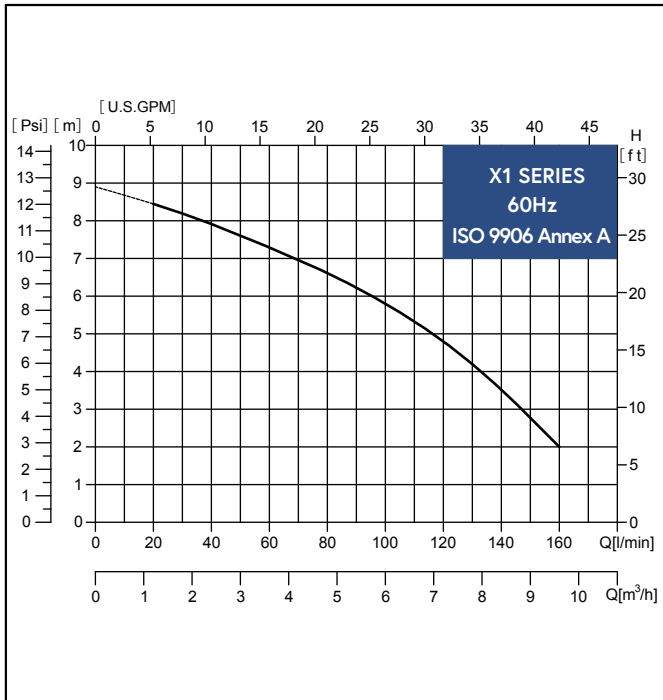

Q=Capacity						
l/min	0	20	40	80	120	160
m ³ /h	0	1.2	2.4	4.8	7.2	9.6
H=Total manometric head						
meters	8.7	8.3	7.7	6.5	4.6	2.1

Model	Dimensions			Pallet dimension L x W x H (cm)	Units/ Pallet
	H	H1	S		
X1-03M-32	274	231	10	110 x 110 x 210	144
X1-03MA-32					
X1-03MS-32					
X1-03T-32					

Specifications

Model	Phase	Voltage	Power		Head Rated	Head Max.	Flow Rated		Flow Max.		Ampere	Connection	Solid Passage	Weight(Kg)
	φ	V	HP	kW	M	M	L/min	m ³ /h	L/min	m ³ /h	FLA (A)	Outlet	(mm)	Cable 10M
X1-03M-32	1	100-115	0.33	0.25	6	8.7	90	5.4	160	9.6	4.6-4.0	1-1/4"	10	5.4
X1-03MA-32														5.6
X1-03MS-32														5.8

• Optional: Minimum suction devices(3mm) are available by request.

Model	Phase	Voltage	Power		Head Rated	Head Max.	Flow Rated		Flow Max.		Ampere	Connection	Solid Passage	Weight(Kg)
	φ	V	HP	kW	M	M	L/min	m ³ /h	L/min	m ³ /h	FLA (A)	Outlet	(mm)	Cable 10M
X1-03M-32	1	220-230	0.33	0.25	6	8.7	90	5.4	160	9.6	2.1/2.0	1-1/4"	10	5.4
X1-03MA-32														5.6
X1-03MS-32														5.8

• Optional: Minimum suction devices(3mm) are available by request.

Model	Phase	Voltage	Power		Head Rated	Head Max.	Flow Rated		Flow Max.		Ampere	Connection	Solid Passage	Weight(Kg)
	φ	V	HP	kW	M	M	L/min	m ³ /h	L/min	m ³ /h	FLA (A)	Outlet	(mm)	Cable 10M
X1-03T-32	3	220-230	0.33	0.25	6	8.7	90	5.4	160	9.6	1.4/1.3	1-1/4"	10	5.3

• Optional: Minimum suction devices(3mm) are available by request.

Model	Phase	Voltage	Power		Head Rated	Head Max.	Flow Rated		Flow Max.		Ampere	Connection	Solid Passage	Weight(Kg)
	φ	V	HP	kW	M	M	L/min	m ³ /h	L/min	m ³ /h	FLA(A)	Outlet	(mm)	Cable 10M
X1-03T-32	3	380-400	0.33	0.25	6	8.7	90	5.4	160	9.6	0.8/0.7	1-1/4"	10	5.3

• Optional: Minimum suction devices(3mm) are available by request.



www.sistema-pumps.com