



# Submersible Wastewater Sump Pump

---

Made in Taiwan



Catalogue 50 Hz





## Index

50Hz

### SD

#### General Data

Model Code	1
Applications	1
Motor	1
Pump	1
Operation Conditions	1
Material	1

#### Technical Data

Performance Curves (Single Phase)	2
Specifications (Single Phase)	2
Dimensions and (Single Phase)	3
Performance Curves (Three Phase)	4
Specifications (Three Phase)	4
Dimensions and Weights (Three Phase)	5

#### Guide Rail series

TS	6
TM	6
TL	6

## SD Series Submersible Wastewater / Sump Pumps

SD series Submersible Wastewater / Sump Pumps are designed for commercial and industrial dewatering, groundwater transferring, effluent transferring, and car washing applications. These pumps include a stainless motor housing, and they are designed to provide great heat dissipation from the motor, ensuring a long service life.

All pumps are 100% pressure-tested, submerged and run to ensure quality and reliability for years of trouble free performance. This attention to detail is an inherent feature of every pump in this series, making it one of the most reliable in the industry.

## General Data

50Hz



### Model Code

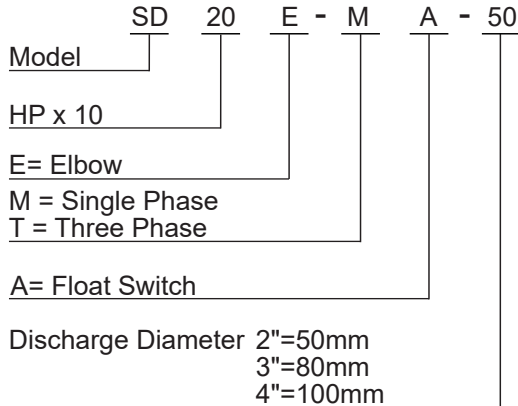

### Applications

- Basement water removal
- Waste water drainage
- Water transfer
- Sump/effluent handling
- Dewatering
- Fish pond & fountain circulation
- Factory waste water handling

### Motor

- Motor Type : 2 POLE , dry type
- Frequency : 50Hz  
Nominal Speed : 2850 rpm
- Insulation Class : F class (155°C)
- Enclosure Protection Class : IP 68
- Protection Device :  
Thermal Protector (Single phase)  
Overload Protector (Three phase)

### Pump

- Impeller : Semi Open Impeller
- Shaft Seal : Double mechanical seal + oil seal
- Bearing : Double-shielded Ball Bearing

### Operation Conditions

- Fluid Temperature: 0 to 40°C (122°F)

### Material

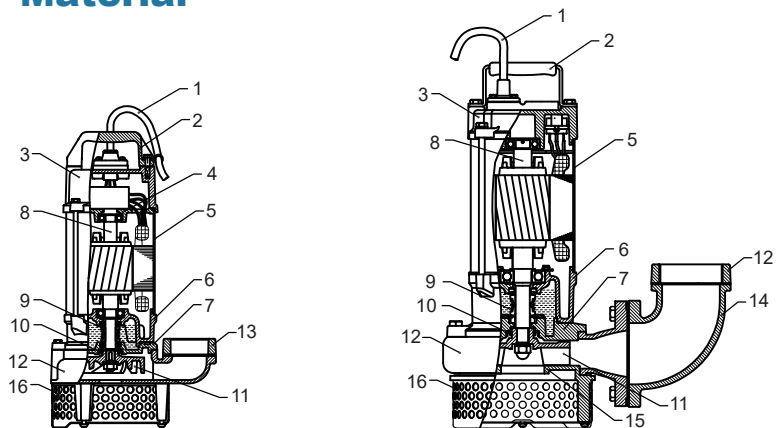

No.	Name	Material
1	Cable	H07RN-F
2	Handle	Nylon6+30GF (0.5~1.0HP)
		AISI 304+NBR (2.0~5.0HP)
3	Motor Cover	FC200
4	Bearing Cap	FC200
5	Motor Frame	AISI 304
6	Bearing Bracket	FC200
7	M.Seal Bracket	FC200
8	Shaft	SUS 410
9	Mechanical Seal	CA/CE,SIC/SIC
10	Oil Seal	NBR 70
11	Impeller	FC200
12	Pump Casing	FC200
13	Flange	FC200
14	Elbow	FC200
15	Suction Cover	FC200
16	Strainer	AISI 304



# SD SERIES - Submersible Wastewater Sump Pump

## SD (Single Phase)

### Technical Data

50Hz

#### Performance Curves

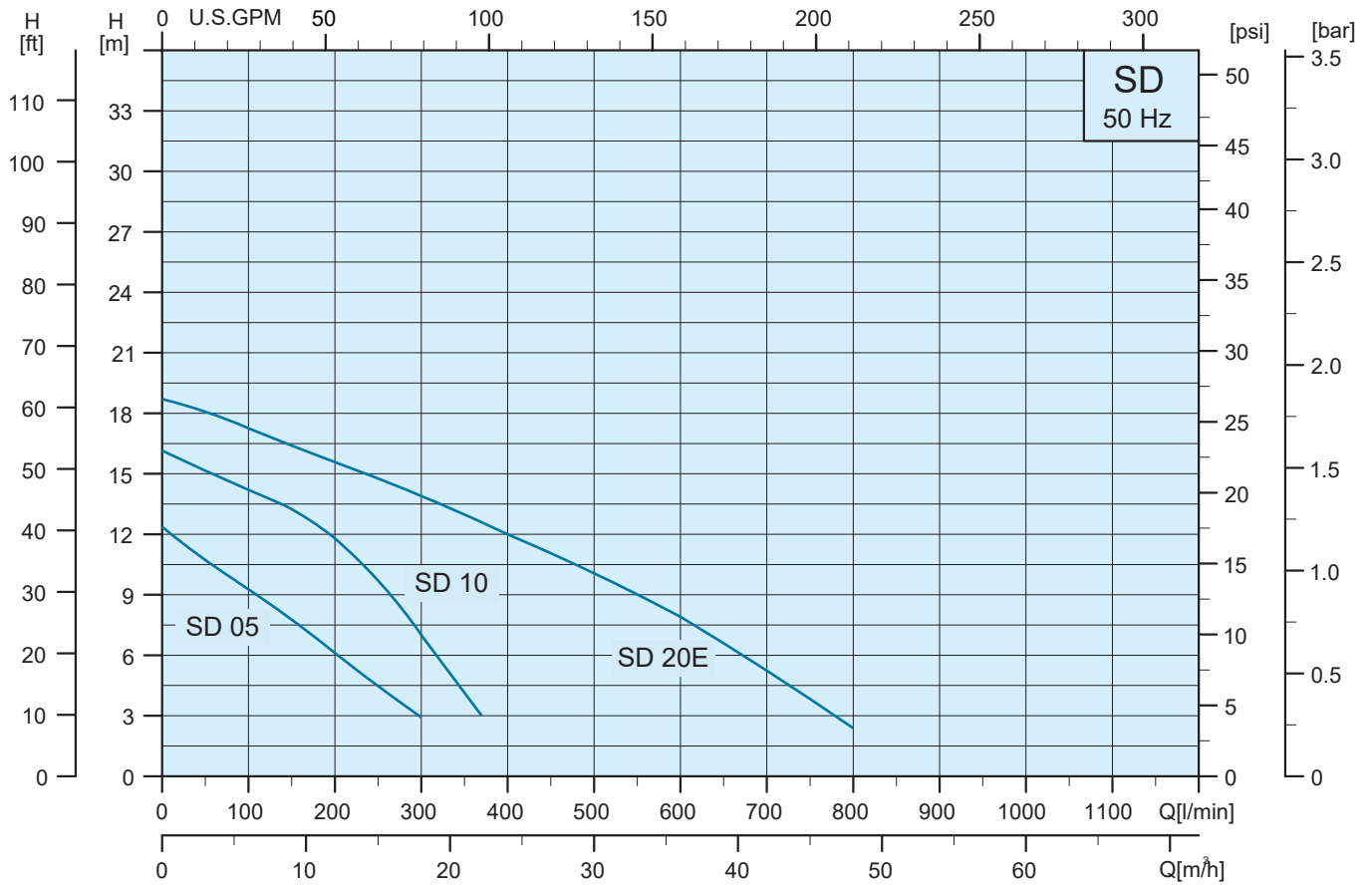

#### Specifications

Model	Q = DELIVERY													
	L/min	0	100	200	300	400	500	600	700	800	900	1000	1100	1200
	m <sup>3</sup> /h	0	6	12	18	24	30	36	42	48	54	60	66	72
<b>Single Phase</b>														
SD 05-M-50	H(m)	12.5	9.3	6.1	2.9	—	—	—	—	—	—	—	—	—
SD 10-M-50		16.5	14.2	11.8	7.0	—	—	—	—	—	—	—	—	—
SD 20E-M-50		18.9	17.2	15.5	14.0	12.0	10.0	8.0	5.2	2.4	—	—	—	—
SD 20E-M-80		18.9	17.2	15.5	14.0	12.0	10.0	8.0	5.2	2.4	—	—	—	—
<b>Single Phase Auto Float Switch</b>														
SD 05-MA-50	H(m)	12.5	9.3	6.1	2.9	—	—	—	—	—	—	—	—	—
SD 10-MA-50		16.5	14.2	11.8	7.0	—	—	—	—	—	—	—	—	—
SD 20E-MA-50		18.9	17.2	15.5	14.0	12.0	10.0	8.0	5.2	2.4	—	—	—	—
SD 20E-MA-80		18.9	17.2	15.5	14.0	12.0	10.0	8.0	5.2	2.4	—	—	—	—

# SD (Single Phase)

## Technical Data

**50Hz**

### Specifications

Model	Power		Input kW	Capacitor		Nominal Current [A] 220-240V	Head		Flow		Discharge inch
	HP	kW		220-240V			Rated (m)	Max. (m)	Rated (L/min)	Max. (L/min)	
			μF	V							
<b>Single Phase</b>											
SD 05-M-50	0.5	0.37	0.7	12	450	3.3-3.0	7.2	12.5	170	300	2"
SD 10-M-50	1.0	0.75	1.1	20	450	5.3-4.9	11.0	16.5	220	370	2"
SD 20E-M-50	2.0	1.5	2.1	40	450	10.0-9.2	10.0	18.9	500	800	2"
SD 20E-M-80	2.0	1.5	2.1	40	450	10.0-9.2	10.0	18.9	500	800	3"
<b>Single Phase Auto Float Switch</b>											
SD 05-MA-50	0.5	0.37	0.7	12	450	3.3-3.0	7.2	12.5	170	300	2"
SD 10-MA-50	1.0	0.75	1.1	20	450	5.3-4.9	11.0	16.5	220	370	2"
SD 20E-MA-50	2.0	1.5	2.1	40	450	10.0-9.2	10.0	18.9	500	800	2"
SD 20E-MA-80	2.0	1.5	2.1	40	450	10.0-9.2	10.0	18.9	500	800	3"

### Dimensions and Weights

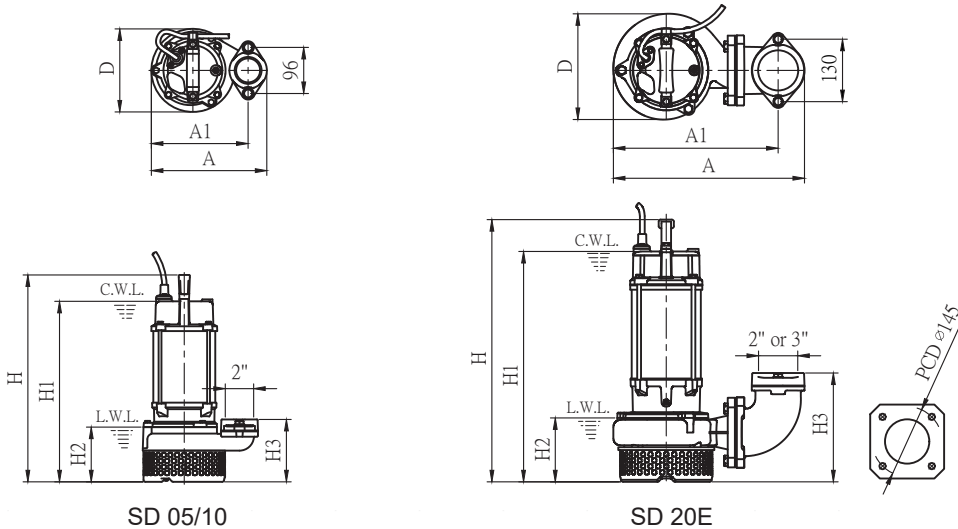

Model	Solids Passage (mm)	Dimensions (mm)							Cable		Net Weights (kg)
		A	A1	D	H	H1	H2	H3	M	H07RN-F	
<b>Single Phase</b>											
SD 05-M-50	10	240	201	173	411	356	114	130	10	3G1.0mm <sup>2</sup>	16.5
SD 10-M-50	10	240	201	173	431	376	114	130	10	3G1.0mm <sup>2</sup>	18.5
SD 20E-M-50	10	398	343	220	546	480	133	227	10	3G1.5mm <sup>2</sup>	42.5
SD 20E-M-80	10	398	343	220	546	480	133	227	10	3G1.5mm <sup>2</sup>	42.5
<b>Single Phase Auto Float Switch</b>											
SD 05-MA-50	10	240	201	173	411	356	114	130	10	3G1.0mm <sup>2</sup>	16.5
SD 10-MA-50	10	240	201	173	431	376	114	130	10	3G1.0mm <sup>2</sup>	18.5
SD 20E-MA-50	10	398	343	220	546	480	133	227	10	3G1.5mm <sup>2</sup>	42.5
SD 20E-MA-80	10	398	343	220	546	480	133	227	10	3G1.5mm <sup>2</sup>	42.5



# SD SERIES - Submersible Wastewater Sump Pump

## SD (Three Phase)

### Technical Data

50Hz

#### Performance Curves

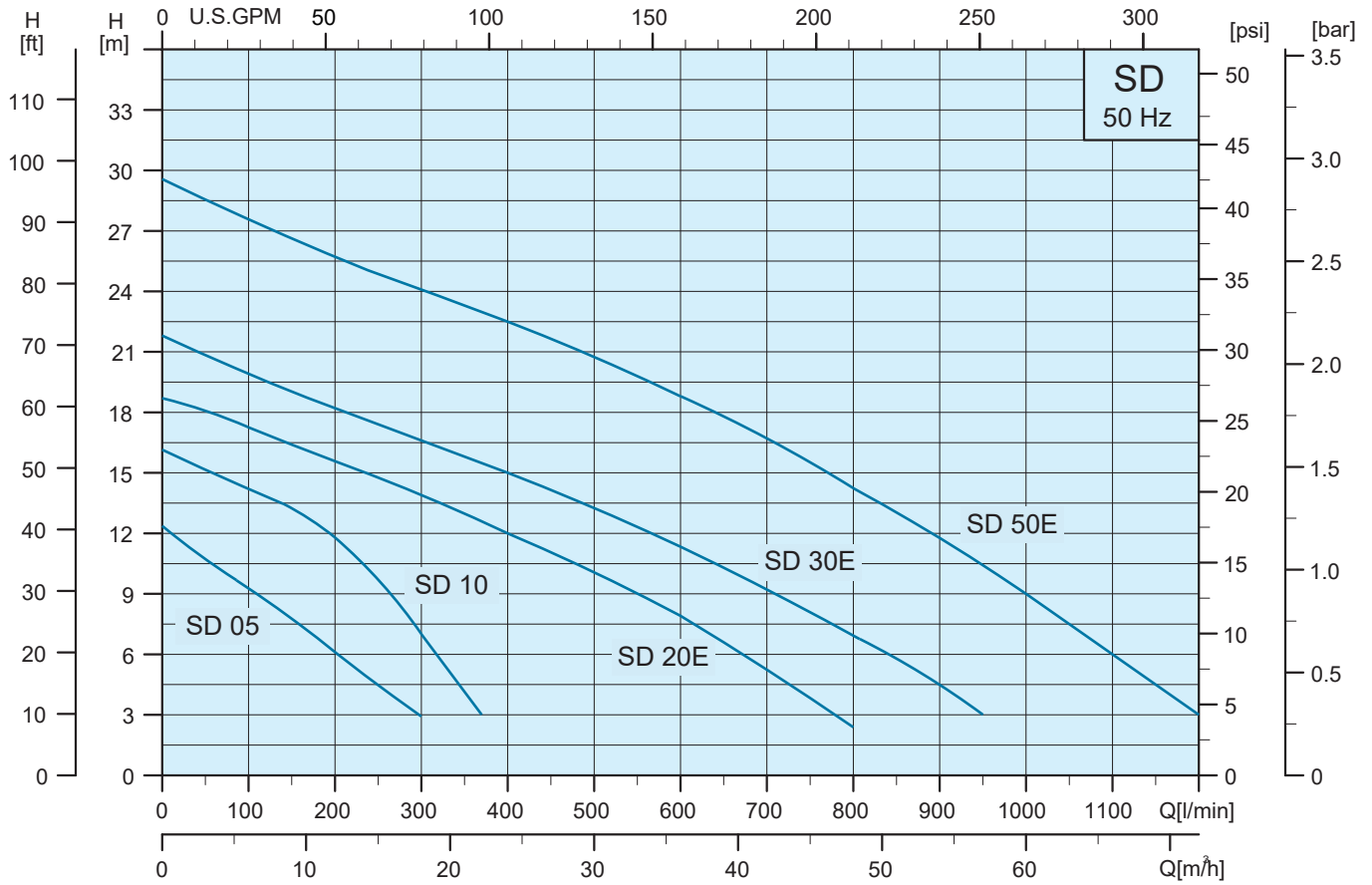

#### Specifications

Model	Q = DELIVERY													
	L/min	0	100	200	300	400	500	600	700	800	900	1000	1100	1200
	m³/h	0	6	12	18	24	30	36	42	48	54	60	66	72
Three Phase														
SD 05-T-50	H(m)	12.5	9.3	6.1	2.9	—	—	—	—	—	—	—	—	—
SD 10-T-50		16.5	14.2	11.8	7.0	—	—	—	—	—	—	—	—	—
SD 20E-T-50		18.9	17.2	15.5	14.0	12.0	10.0	8.0	5.2	2.4	—	—	—	—
SD 20E-T-80		18.9	17.2	15.5	14.0	12.0	10.0	8.0	5.2	2.4	—	—	—	—
SD 30E-T-50		22.0	19.9	18.2	16.6	15.0	13.2	11.3	9.2	7.0	4.5	—	—	—
SD 30E-T-80		22.0	19.9	18.2	16.6	15.0	13.2	11.3	9.2	7.0	4.5	—	—	—
SD 50E-T-80		29.6	27.5	25.5	24.2	22.5	21.0	18.8	17.0	14.0	11.5	9.0	6.0	3.0
SD 50E-T-100		29.6	27.5	25.5	24.2	22.5	21.0	18.8	17.0	14.0	11.5	9.0	6.0	3.0

# SD (Three Phase)

## Technical Data

**50Hz**

### Specifications

Model	Power		Input	Nominal Current [A]		Head		Flow		Discharge inch
	HP	kW	kW	220-240V	380-415V	Rated (m)	Max. (m)	Rated (L/min)	Max. (L/min)	
<b>Three Phase</b>										
SD 05-T-50	0.5	0.37	0.7	2.4-2.0	1.3-1.0	7.2	12.5	170	300	2"
SD 10-T-50	1.0	0.75	1.1	3.5-3.1	2.1-1.7	11.0	16.5	220	370	2"
SD 20E-T-50	2.0	1.5	2.0	6.5-6.0	3.5-3.0	10.0	18.9	500	800	2"
SD 20E-T-80	2.0	1.5	2.0	6.5-6.0	3.5-3.0	10.0	18.9	500	800	3"
SD 30E-T-50	3.0	2.2	2.9	8.7-8.0	5.0-4.5	14.0	22.0	460	950	2"
SD 30E-T-80	3.0	2.2	2.9	8.7-8.0	5.0-4.5	14.0	22.0	460	950	3"
SD 50E-T-80	5.0	3.7	4.5	14.2-13.0	8.2-7.7	20.0	29.6	540	1200	3"
SD 50E-T-100	5.0	3.7	4.5	14.2-13.0	8.2-7.7	20.0	29.6	540	1200	4"

### Dimensions and Weights

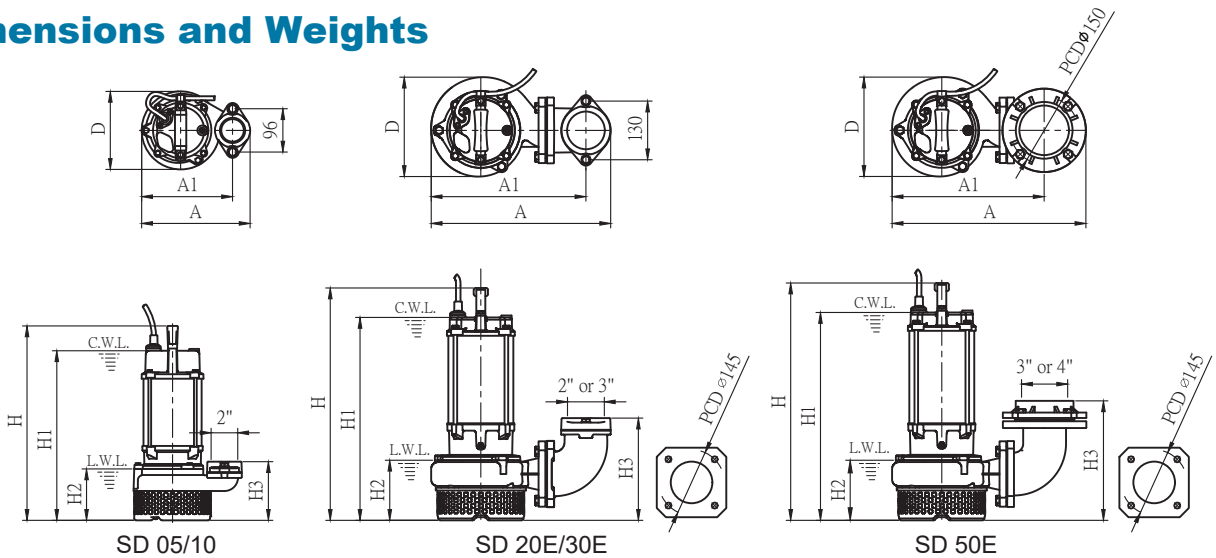

Model	Solids Passage (mm)	Dimensions (mm)							Cable		Net Weights (kg)
		A	A1	D	H	H1	H2	H3	M	H07RN-F	
<b>Three Phase</b>											
SD 05-T-50	10	240	201	173	411	356	114	130	10	4G1.0mm <sup>2</sup>	15.5
SD 10-T-50	10	240	201	173	431	376	114	130	10	4G1.0mm <sup>2</sup>	17.5
SD 20E-T-50	10	398	343	220	506	441	133	227	10	4G1.5mm <sup>2</sup>	36.0
SD 20E-T-80	10	398	343	220	506	441	133	227	10	4G1.5mm <sup>2</sup>	36.0
SD 30E-T-50	10	398	343	220	506	441	133	227	10	4G1.5mm <sup>2</sup>	38.5
SD 30E-T-80	10	398	343	220	506	441	133	227	10	4G1.5mm <sup>2</sup>	38.5
SD 50E-T-80	10	430	337	220	526	461	133	265	10	4G2.5mm <sup>2</sup>	45.0
SD 50E-T-100	10	430	337	220	526	461	133	265	10	4G2.5mm <sup>2</sup>	45.0



## Guide Rail series

50Hz

### TS

Guide Rail Model	Pump Model	Dimensions (mm)
		H1
TS 50	SD 05	31.0
	SD 10	

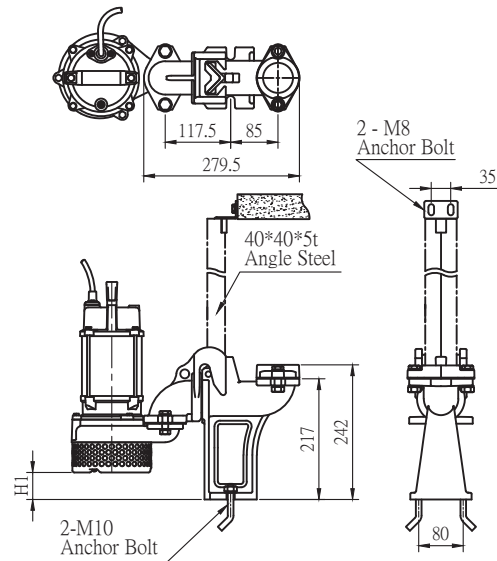

### TM

Guide Rail Model	Pump Model	Dimensions (mm)
		H1
TM 50 TM 80	SD 20E	77.5
	SD 30E	
	SD 50E	

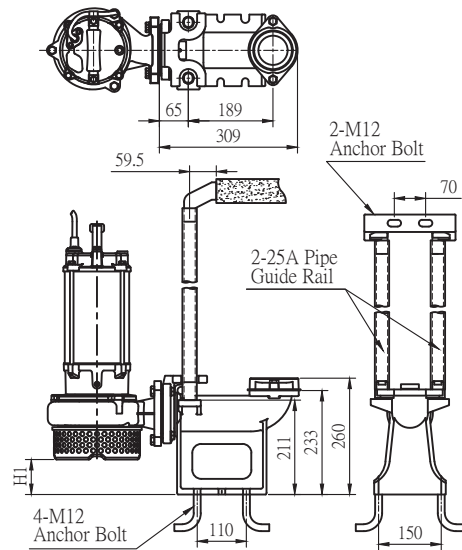

### TL

Guide Rail Model	Pump Model	Dimensions (mm)
		H1
TL 80 TL 100	SD 50E	104.5

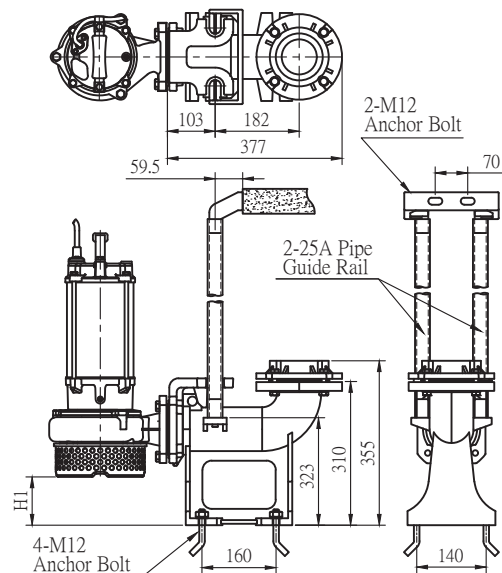







[www.sistema-pumps.com](http://www.sistema-pumps.com)