



Submersible Grinder Pump

Made in Taiwan



Catalogue 60 Hz

MODEL CODE

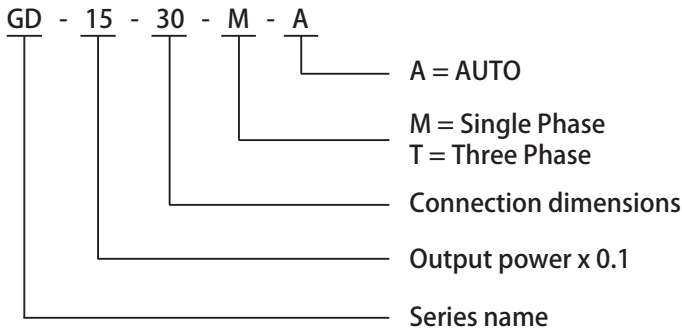

APPLICATION

- General household use, Drainage systems for Buildings Apartments, Resorts and Wastewater systems.
- Materials such as leather, textile fibres, food and other tougher objects can be pumped.
- Wastewater systems for Domestic, Commercial, Industrial, Municipal, Schools, Hospitals and many other uses.
- Sewage and Drainage systems.

MATERIAL AND STANDARD TABLE

Caliber		32mm · 50mm	
Liquid	Temperature	0° C~40° C(32° F~104° F)	
	The lowest depth	▽30 M	
Pump	Impeller	Centrifugal Vortex Impeller	
	Material	Upper Cover	FC-200
		Bracket	FC-200
		Bearing	Heavy-duty bearing
		Impeller	FC-200
		Volute Casing	FC-200
		Motor Bracket	FC-200
		Mechanical Seal Bracket	FC-200
		Radial Cutter	SUS-440C
	Radial Ring	SUS-440C	
	Seal	Lubricant	ISO VG.#32
Motor Side		Carbon / Ceramic	
Pump Side		Silicon Carbide / Silicon Carbide	
Motor	Type	Submersible dry type	
	Pump	Protection Class: IP 68.	
	Insulation class	F class(155° C)	
	Inner protector	Auto Reset Motor Protector	
	Material	Casing	FC-200
		Main Shaft	SUS-410 / SUS-420
Cable		Standard H07	

ADVANTAGES

- Robust construction.
- Superior Heat Dissipation.
- Macerating Impellor for cutting up materials.
- Double mechanical seals Upper : CA/CE
Lower : SIC/SIC

PERFORMANCE CURVES

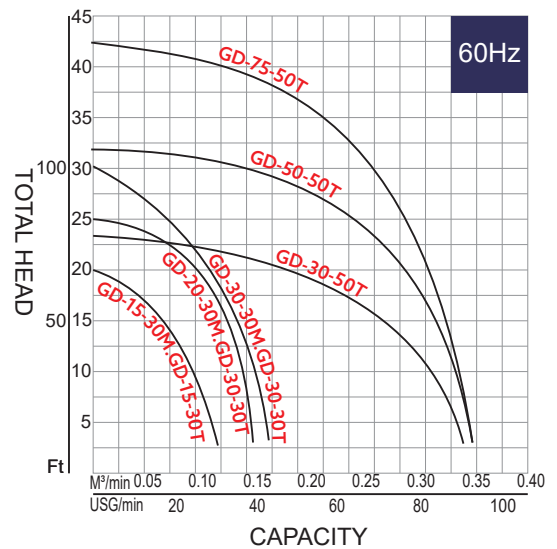

INDUSTRY APPLICATION



Structural Drawing

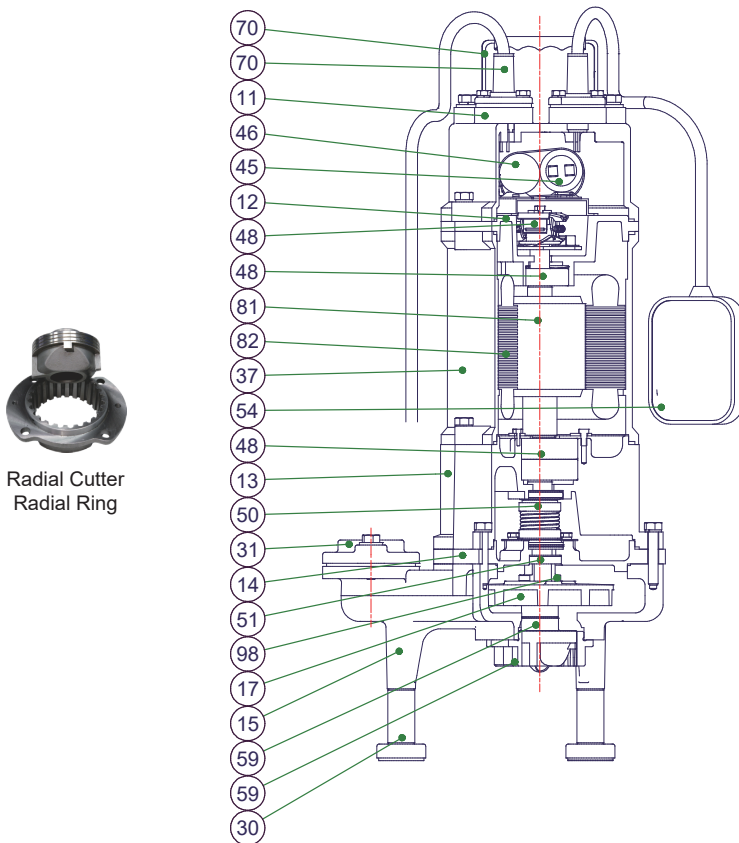

ITEN NO.	PART LIST	MATERIAL
11	Upper Cover	Cast Iron
12	Bracket	Cast Iron
13	Motor Bracket	Cast Iron
14	Mechanical Seal Bracket	Cast Iron
15	Pump Casing	Cast Iron
17	Impeller	Cast Iron
30	Base Stand	
31	Outlet Flange	Plastic
37	Motor Frame	Cast Iron
45	Start Condenser	
46	Running Condenser	
47	Centrifugal Switch	
48	Bearing	
50	Mechanical Seal	SIC
51	Oil Seal	NBR
54	Float Switch	
59	Mincer	Srainless Steel
70	Cable	PVC/VCT
71	Handle	Stainless Steel
81	Rotor Set	
82	Motor Coil	
90	Lubricaant	
98	Oil Seal Bushing	Stainless Steel

Specification

Model	Power		Max.Current(A)			Discharge		Pole/Rotaion	Head(Pressure)		Flow(L/min)		Cable	Weight
			1Ø	3Ø	440-460V				Rated(M)	Max.(M)	Rated(M)	Max.(M)		
	HP	kW	220-240V	380-415V		Inch	mm	P/rpm					M	KG
GD-15-30M	1.5	1.1	10.0-9.5	-	-	1.25"	32	2P/3450	16	20	60	120	10	32.7
GD-15-30MA	1.5	1.1	10.0-9.5	-	-	1.25"	32	2P/3450	16	20	60	120	10	33.2
GD-20-30M	2.0	1.5	11.0-10.0	-	-	1.25"	32	2P/3450	23	25	60	150	10	36.0
GD-20-30MA	2.0	1.5	11.0-10.0	-	-	1.25"	32	2P/3450	23	25	60	150	10	36.5
GD-30-30M	3.0	2.2	15.0-13.75	-	-	1.25"	32	2P/3450	26	30	60	160	10	39.0
GD-15-30T	1.5	1.1	5.5-5.1	3.5-3.2	3.1-3.0	1.25"	32	2P/3450	16	20	60	120	10	31.5
GD-20-30T	2.0	1.5	7.5-7.0	4.5-4.2	4.0-3.6	1.25"	32	2P/3450	23	25	60	150	10	33.5
GD-30-30T	3.0	2.2	11.0-10.0	6.5-6.0	5.5-5.3	1.25"	32	2P/3450	26	30	60	160	10	36.0
GD-30-50T	3.0	2.2	11.0-10.0	6.5-6.0	5.5-5.3	2"	50	2P/3450	19	23	200	350	10	44.5
GD-50-50T	5.0	3.7	14.0-13.0	8.0-7.5	7.0-6.7	2"	50	2P/3450	28	32	200	350	10	48.0
GD-75-50T	7.5	5.5	18.0-16.5	10.5-9.6	9.0-8.6	2"	50	2P/3450	36	42.5	200	350	10	54.0

Dimensions

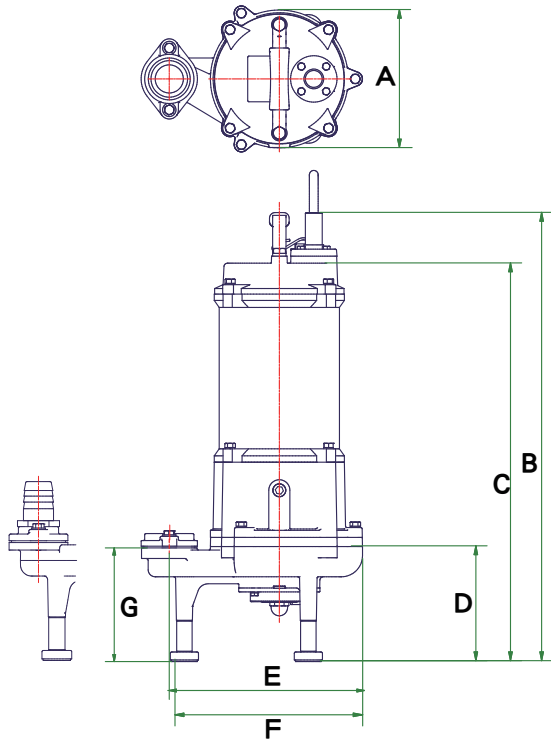

GD-15、20、30、50、75

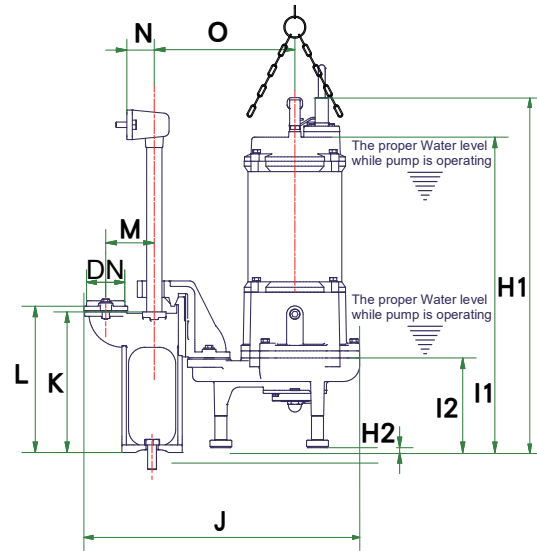

GD-15、20、30、50、75

Dimensions (mm)

Model	A	B	C	D	E	F	G	H1	H2	I1	I2	J	K	L	M	N	O	DN
GD-15-30M	185	591	520	161	241	280	159	601	14	530	172	467	257	277	89	50	238	1.25"
GD-15-30MA	187	592	521	161	241	280	159	601	14	530	172	467	257	277	89	50	238	1.25"
GD-20-30M	185	611	540	161	241	280	159	622	14	551	172	467	257	277	89	50	238	1.25"
GD-20-30MA	187	612	541	161	241	280	157	622	14	551	172	467	257	277	89	50	238	1.25"
GD-30-30M	196	574	502	164	275	315	162	583	11	511	173	504	257	277	89	50	257	2"
GD-15-30T	185	543	472	161	241	280	159	622	14	553	172	467	257	277	89	50	238	1.25"
GD-20-30T	185	561	503	159	241	280	157	575	14	504	172	468	257	277	89	50	238	1.25"
GD-30-30T	196	574	502	164	275	315	162	583	11	511	173	504	257	277	89	50	257	2"
GD-30-50T	196	574	502	164	275	315	162	583	11	511	173	504	257	277	89	50	257	1.25"
GD-50-50T	196	594	522	164	275	315	162	603	11	531	173	504	257	277	89	50	257	2"
GD-75-50T	196	639	567	164	275	315	162	648	11	576	173	503	257	277	89	50	257	2"

TOS(Guide Rail System)



GD-15.20.30.50.75

SPECIFICATION

Model	TYPE (FC200)	Discharge	
		Inch	mm
GD-15.20.30	TOS-1.25	1.25"	30
GD-30.50.75	TOS-2	2"	50

GUIDE RAIL CONF

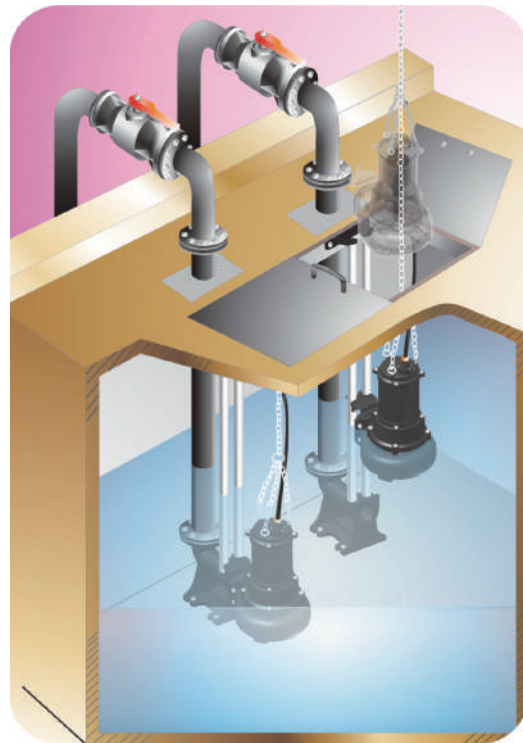

GUIDE RAIL SYSTEM

GD Series with pump stool and guide rail system make it easy for removal, dismantling, repair and maintenance of Pumps, Motors, Float switches etc.

ATTENTION

The GD Lifting device option is not included in the price of Pumps and may be purchased separately.

APPLICATION

Piggery excrement, factory sewage, food-processing factory, leather factory, paper dyeing, iron and steel, and various industries.

FLOAT SWITCH OPERATION DRAWING

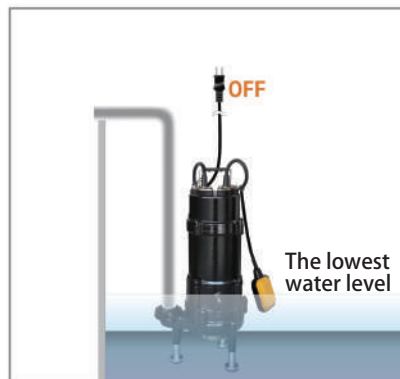
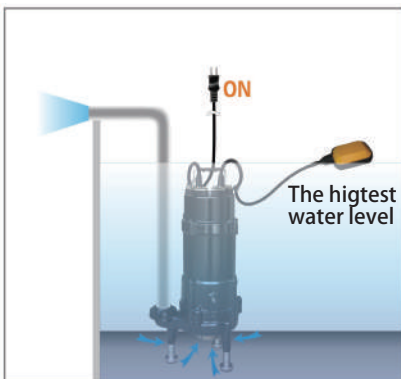

⊗Take heed of pump's cable not entangling with switch float's to keep the efficiency of liquid control when installing pumps.



www.sistema-pumps.com