



Submersible Vortex Sewage Pump

Made in Taiwan



Catalogue 50 Hz



Index

50Hz

SV

General Data

Model Code	1
Applications	1
Motor	1
Pump	1
Operation Conditions	1
Material	1

Technical Data

SV 50Hz (Single Phase)	2
SV 50Hz (Three Phase)	4

Guide Rail series

TS	6
TM	6
TL	6

SV series Submersible Sewage / Effluent Pumps

SV series Submersible Sewage / Effluent Pumps are designed for commercial and industrial wastewater transferring and dewatering applications.

The innovative vortex impeller design reduces the risk of clogging problem. Moreover, SV series include a stainless steel motor frame to prevent corrosion and are designed to provide great heat dissipation from the motor, ensuring a long service life.

As with pump, each one is 100% tested to ensure quality and reliability for years of trouble-free performance.

General Data

50Hz



Model Code

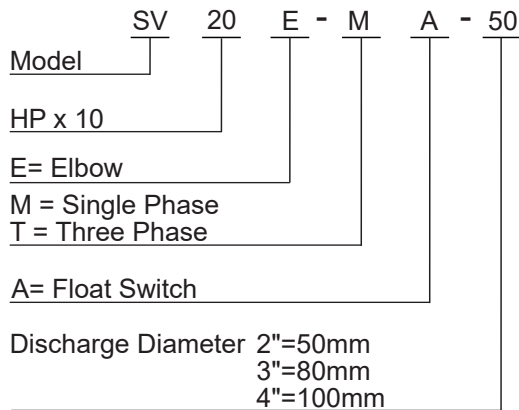

Applications

- Basement water removal
- Waste water drainage
- Water transfer
- Sump/effluent handling
- Dewatering
- Fish pond & fountain circulation
- Factory waste water handling

Motor

- Motor Type : 2 POLE , dry type
- Frequency : 50Hz
Nominal Speed : 2850 rpm
- Insulation Class : F class (155°C)
- Enclosure Protection Class : IP 68
- Protection Device :
Thermal Protector (Single phase)
Overload Protector (Three phase)

Pump

- Impeller : Vortex impeller
- Shaft Seal : Double mechanical seal + oil seal
- Bearing : Double-shielded Ball Bearing

Operation Conditions

- Fluid Temperature: 0 to 40°C (122°F)

Material

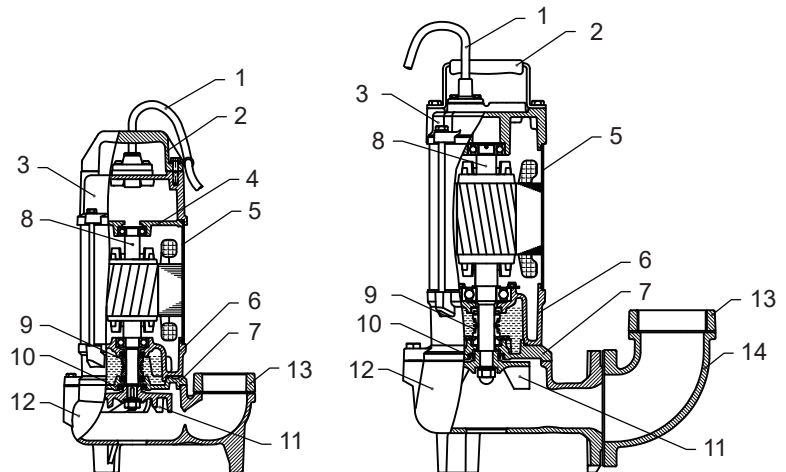

No.	Name	Material
1	Cable	H07RN-F
2	Handle	Nylon6+30GF(0.5~1.0HP)
		AISI 304+NBR(2.0~5.0HP)
3	Motor Cover	FC200
4	Bearing Cap	FC200
5	Motor Frame	AISI 304
6	Bearing Bracket	FC200
7	M.Seal Bracket	FC200
8	Shaft	SUS 410
9	Mechanical Seal	CA/CE,SIC/SIC
10	Oil Seal	NBR 70
11	Impeller	FC200
12	Pump Casing	FC200
13	Flange	FC200
14	Elbow	FC200



SV SERIES - Submersible Vortex Sewage Pump

SV (Single Phase)

Technical Data

50Hz

Performance Curves

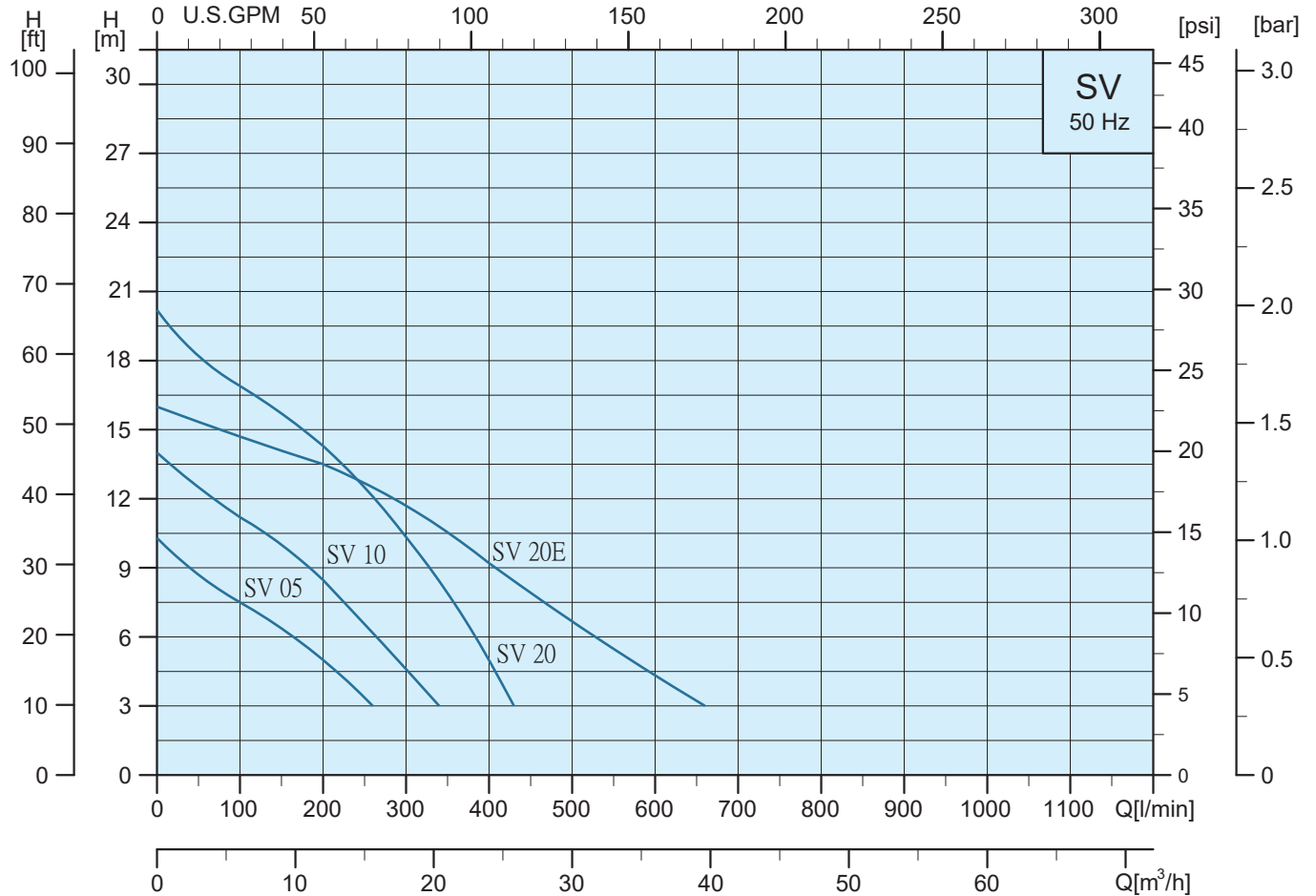

Specifications

Model	Q = DELIVERY											
	L/min	0	100	200	300	400	500	600	700	800	900	1000
	m³/h	0	6	12	18	24	30	36	42	48	54	60
Single Phase												
SV 05-M-50	H(m)	10.3	7.5	5.0	—	—	—	—	—	—	—	—
SV 10-M-50		14.0	11.2	8.5	4.6	—	—	—	—	—	—	—
SV 20-M-50		20.2	17.0	14.4	10.3	5.0	—	—	—	—	—	—
SV 20E-M-50		16.0	14.7	13.5	11.7	9.2	6.7	4.1	—	—	—	—
SV 20E-M-80		16.0	14.7	13.5	11.7	9.2	6.7	4.1	—	—	—	—
Single Phase Auto Float Switch												
SV 05-MA-50	H(m)	10.3	7.5	5.0	—	—	—	—	—	—	—	—
SV 10-MA-50		14.0	11.2	8.5	4.6	—	—	—	—	—	—	—
SV 20-MA-50		20.2	17.0	14.4	10.3	5.0	—	—	—	—	—	—
SV 20E-MA-50		16.0	14.7	13.5	11.7	9.2	6.7	4.1	—	—	—	—
SV 20E-MA-80		16.0	14.7	13.5	11.7	9.2	6.7	4.1	—	—	—	—

SV (Single Phase)

Technical Data

50Hz

Specifications

Model	Power		Input kW	Capacitor		Max.Amp [A] 220-240V	Head		Flow		Discharge inch
	HP	kW		220-240V			Rated (m)	Max. (m)	Rated (L/min)	Max. (L/min)	
			μF	V							
Single Phase											
SV 05-M-50	0.5	0.37	0.6	12	450	3.6-3.4	6.0	10.3	170	260	2"
SV 10-M-50	1.0	0.75	1.0	20	450	5.2-4.8	9.0	14.0	185	430	2"
SV 20-M-50	2.0	1.5	2.2	40	450	10.0-9.2	12.0	21.0	285	420	2"
SV 20E-M-50	2.0	1.5	2.2	40	450	10.0-9.2	10.0	16.0	370	660	2"
SV 20E-M-80	2.0	1.5	2.2	40	450	10.0-9.2	10.0	16.0	370	660	3"
Single Phase Auto Float Switch											
SV 05-MA-50	0.5	0.37	0.6	12	450	3.6-3.4	6.0	10.3	170	260	2"
SV 10-MA-50	1.0	0.75	1.0	20	450	5.2-4.8	9.0	14.0	185	430	2"
SV 20-MA-50	2.0	1.5	2.2	40	450	10.0-9.2	12.0	21.0	285	420	2"
SV 20E-MA-50	2.0	1.5	2.2	40	450	10.0-9.2	10.0	16.0	370	660	2"
SV 20E-MA-80	2.0	1.5	2.2	40	450	10.0-9.2	10.0	16.0	370	660	3"

Dimensions and Weights

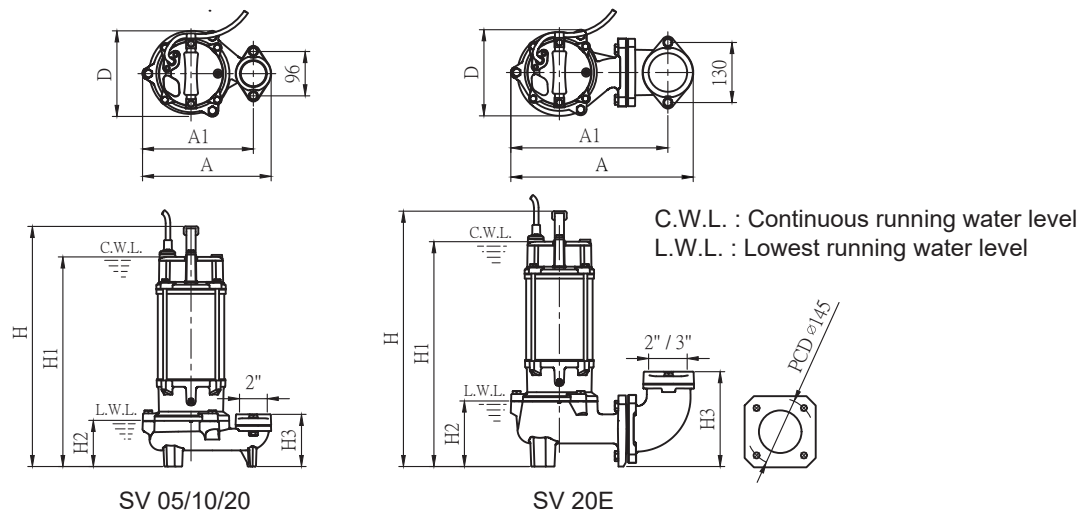

Model	Solids Passage (mm)	Dimensions (mm)							Cable		Net Weights (kg)
		A	A1	D	H	H1	H2	H3	m	H07RN-F	
Single Phase											
SV 05-M-50	35	240	201	153	406	352	110	124	10	3G1.0mm ²	17.0
SV 10-M-50	35	240	201	153	426	372	110	124	10	3G1.0mm ²	18.5
SV 20-M-50	35	279	240	186	520	454	100	112	10	3G1.5mm ²	30.0
SV 20E-M-50	50	395	340	186	562	496	141	205	10	3G1.5mm ²	37.0
SV 20E-M-80	50	395	340	186	562	496	141	205	10	3G1.5mm ²	37.0
Single Phase Auto Float Switch											
SV 05-MA-50	35	240	201	153	406	352	110	124	10	3G1.0mm ²	17.0
SV 10-MA-50	35	240	201	153	426	372	110	124	10	3G1.0mm ²	18.5
SV 20-MA-50	35	279	240	186	520	454	100	112	10	3G1.5mm ²	30.0
SV 20E-MA-50	50	395	340	186	562	496	141	205	10	3G1.5mm ²	37.0
SV 20E-MA-80	50	395	340	186	562	496	141	205	10	3G1.5mm ²	37.0



SV SERIES - Submersible Vortex Sewage Pump

SV (Three Phase)

Technical Data

50Hz

Performance Curves

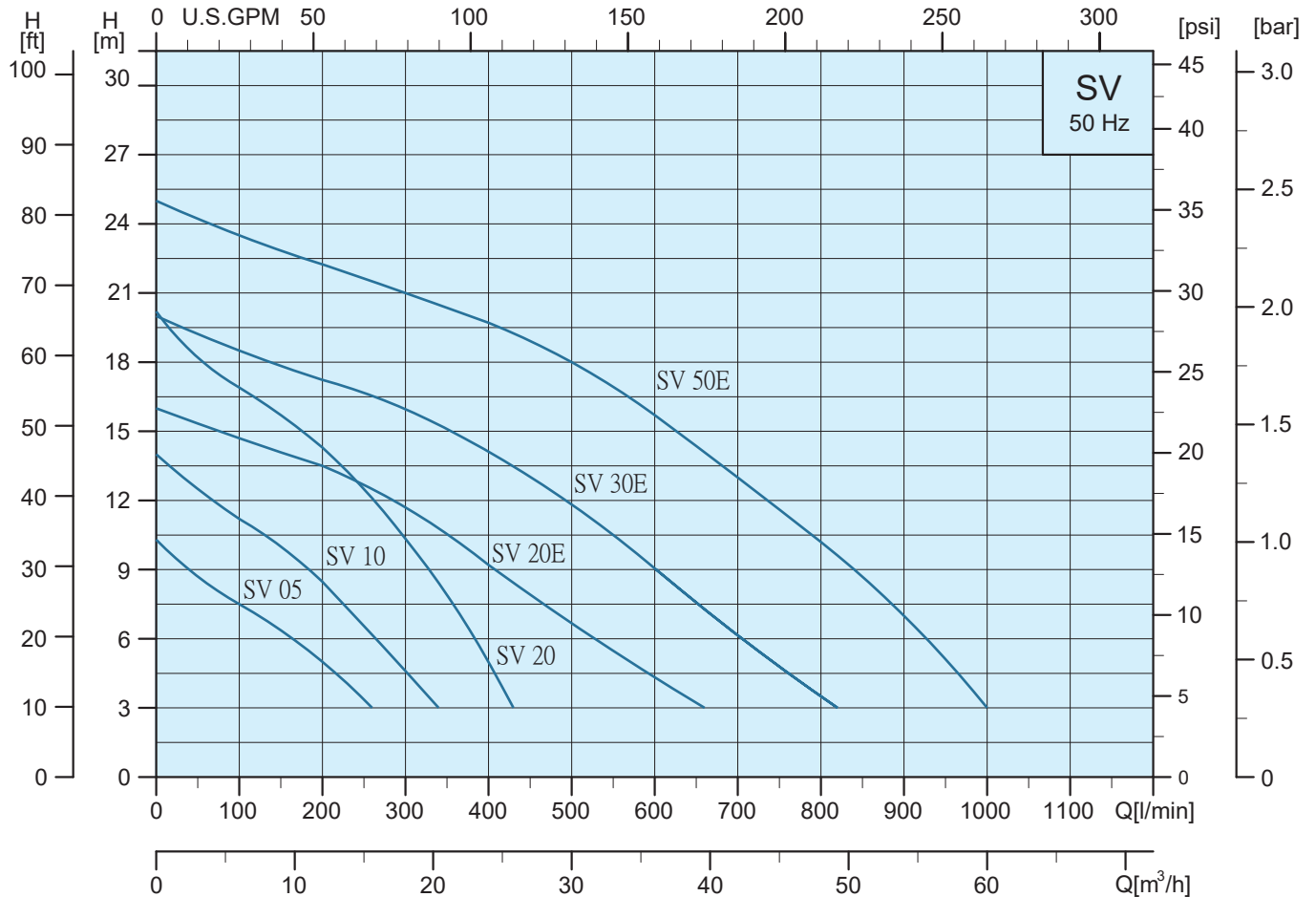

Specifications

Model	Q = DELIVERY											
	L/min	0	100	200	300	400	500	600	700	800	900	1000
	m³/h	0	6	12	18	24	30	36	42	48	54	60
Three Phase												
SV 05-T-50	H(m)	10.3	7.5	5.0	—	—	—	—	—	—	—	—
SV 10-T-50		14.0	11.2	8.5	4.6	—	—	—	—	—	—	—
SV 20-T-50		20.2	17.0	14.4	10.3	5.0	—	—	—	—	—	—
SV 20E-T-50		16.0	14.7	13.5	11.7	9.2	6.7	4.1	—	—	—	—
SV 20E-T-80		16.0	14.7	13.5	11.7	9.2	6.7	4.1	—	—	—	—
SV 30E-T-50		20.0	18.5	17.2	16.0	14.0	12.0	9.0	6.0	35.0	—	—
SV 30E-T-80		20.0	18.5	17.2	16.0	14.0	12.0	9.0	6.0	35.0	—	—
SV 50E-T-80		25.0	23.5	22.2	21.0	19.7	18.0	15.7	13.0	10.2	7.0	3.0
SV 50E-T-100		25.0	23.5	22.2	21.0	19.7	18.0	15.7	13.0	10.2	7.0	3.0

SV (Three Phase)

Technical Data

50Hz

Specifications

Model	Power		Input kW	Max.Amp [A]		Head		Flow		Discharge inch	
	HP	kW		220-240V	380-415V	Rated (m)	Max. (m)	Rated (L/min)	Max. (L/min)		
Three Phase											
SV 05-T-50	0.5	0.37	0.6	2.5-2.3	1.5-1.3	6.0	10.3	170	260	2"	2"
SV 10-T-50	1.0	0.75	1.0	3.5-3.2	2.0-1.8	9.0	14.0	185	430	2"	2"
SV 20-T-50	2.0	1.5	2.2	6.5-6.5	3.7-3.5	12.0	21.0	285	420	2"	2"
SV 20E-T-50	2.0	1.5	2.2	6.5-6.0	3.7-3.5	10.0	16.0	370	660	2"	2"
SV 20E-T-80	2.0	1.5	2.2	6.5-6.0	3.7-3.5	10.0	16.0	370	660	3"	3"
SV 30E-T-50	3.0	2.2	2.9	8.7-8.0	5.0-4.6	13.0	20.0	450	820	2"	2"
SV 30E-T-80	3.0	2.2	2.9	8.7-8.0	5.0-4.6	13.0	20.0	450	820	3"	3"
SV 50E-T-80	5.0	3.7	4.5	14.2-13.0	8.2-7.6	18.0	25.0	500	1000	3"	3"
SV 50E-T-100	5.0	3.7	4.5	14.2-13.0	8.2-7.6	18.0	25.0	500	1000	4"	4"

Dimensions and Weights

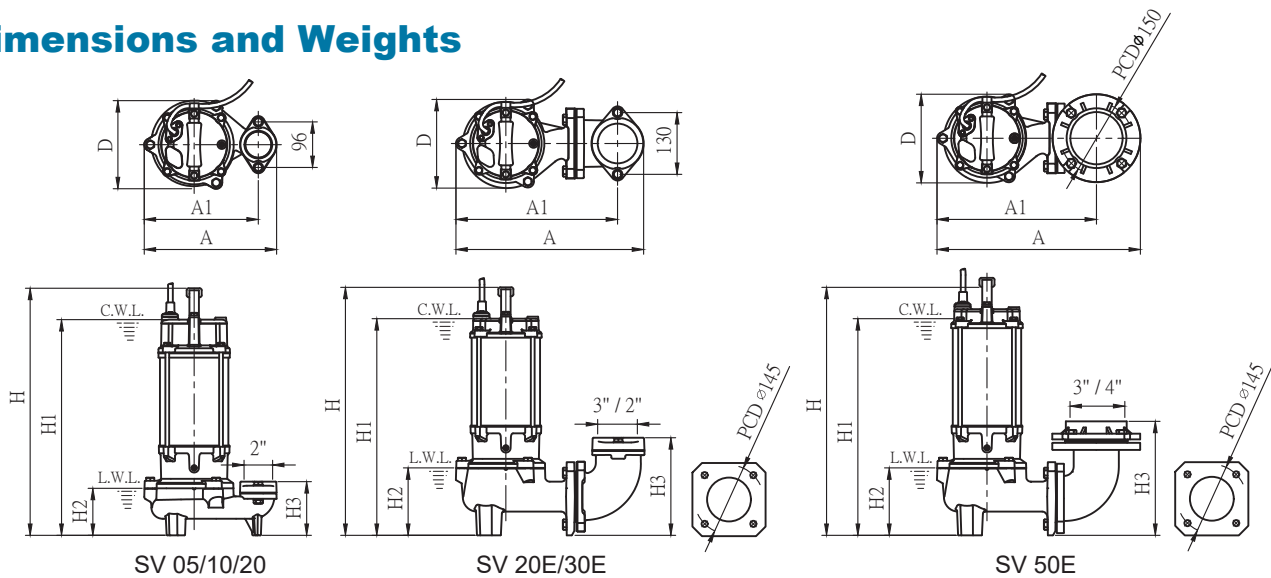

Model	Solids Passage (mm)	Dimensions (mm)							Cable		Net Weights (kg)
		A	A1	D	H	H1	H2	H3	m	H07RN-F	
Three Phase											
SV 05-T-50	35	240	201	153	406	352	110	124	10	4G1.0mm ²	16.0
SV 10-T-50	35	240	201	153	426	372	110	124	10	4G1.0mm ²	17.5
SV 20-T-50	35	279	240	186	480	414	100	112	10	4G1.5mm ²	27.0
SV 20E-T-50	50	395	340	186	522	456	141	205	10	4G1.5mm ²	34.0
SV 20E-T-80	50	395	340	186	522	456	141	205	10	4G1.5mm ²	34.0
SV 30E-T-50	50	395	340	186	522	456	141	205	10	4G1.5mm ²	36.5
SV 30E-T-80	50	395	340	186	522	456	141	205	10	4G1.5mm ²	36.5
SV 50E-T-80	50	428	335	186	542	476	141	240	10	4G2.5mm ²	41.0
SV 50E-T-100	50	428	335	186	542	476	141	240	10	4G2.5mm ²	41.0

C.W.L. : Continuous running water level

L.W.L. : Lowest running water level

Guide Rail series

50Hz

TS

Guide Rail Model	Model	Dimensions (mm)
		H1
TS 50	SV 05	37.0
	SV 10	

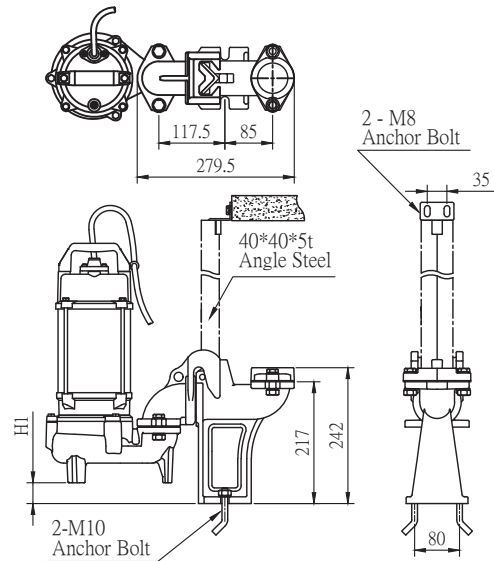

TM

Guide Rail Model	Model	Dimensions (mm)
		H1
TM 50 TM 80	SV 20E	99.5
	SV 30E	
	SV 50E	

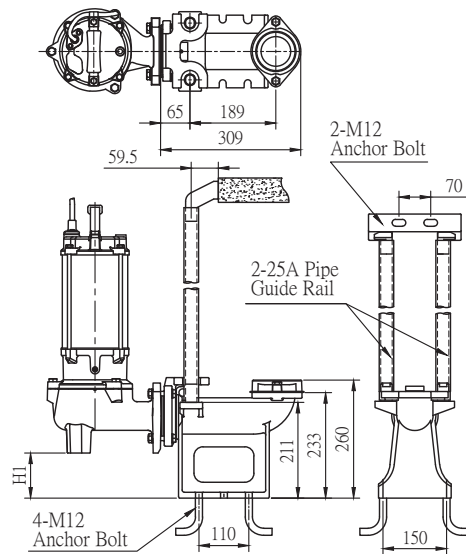

TL

Guide Rail Model	Model	Dimensions (mm)
		H1
TL 80 TL 100	SV 50E	126.5

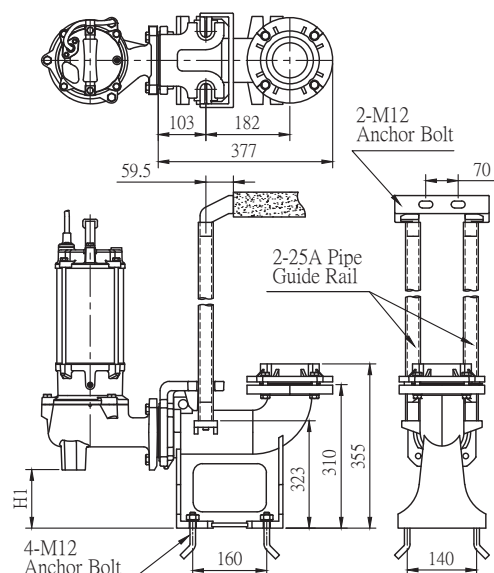



www.sistema-pumps.com