



6" Encapsulated Water Filled Submersible Motors

Made in Turkey



Catalogo 50/60 Hz

Encapsulated Water Filled Submersible Motors

Water cooled motors with encapsulated resin filled stator.
Coupling dimensions and flange according to NEMA standard.

General Features

5,5-60 HP / 3PH. 380-415 Volts / 50Hz

High efficiency provides operation cost savings

Motor casing and shaft made of AISI304L stainless steel (Optional AISI316L)

High resistance coated cast iron upper and lower bracket (Optional

AISI304L / AISI316L) Water lubricated Kingsbury type thrust bearings

Protection IP68

Sand slinger protection

Pressure equalizing diaphragm

Insulation class F

Removable lead cable

Starting method D.O.L. and star/delta



Operating Limits

Max. voltage fluctuation: $\pm 10\%$

Max. water temperature: 35°C with at least 0.16 m/s of water flow

speed Max. motor startings per hour: 20

Max. immersion depth: 350 m

Standard mounting position: vertical and horizontal



Practical cable connection

Extremely simple and very practical power cable connection to the motor body.



Slinger (sand guard)

Slinger helps to prevent the sand inside the well entering in mechanical seal and through mechanical seal to inside of the motor.



Water lubricated radial carbon bearings

Radial carbon bearings, which have channels in its structure that makes it possible to get lubricated by water easily, provides precise bearing of rotor shaft at up and down.



High thrust capacity

Heavy duty bearings provides the option to revolve both sides, has the capacity to carry high thrust load.



High quality mechanical sealing system

High sand resistance and degree of IP68 protection. Although mechanical seal is optionally used by other companies, it is always used by Vansan as a standard, to prevent sand and other particles to get in motors to provide long bearing life.



Adjustment screw

Standard shaft height can be precisely adjusted by the adjustment screw on the thrust bearing base.



Up-Thrust ring

Provides safe operation conditions for motor by absorbing Up-Thrust loads with its machined surface and water channels on it.



Pressure balancing checkvalve

When the pressure increases, it throw water out of the motor. When the pressure drops, it filtrates the water inside well and gets it inside the motor by the help of this checkvalve to balance the pressure inside. That's why pressure differences inside motor never causes membrane under motor to blow up.

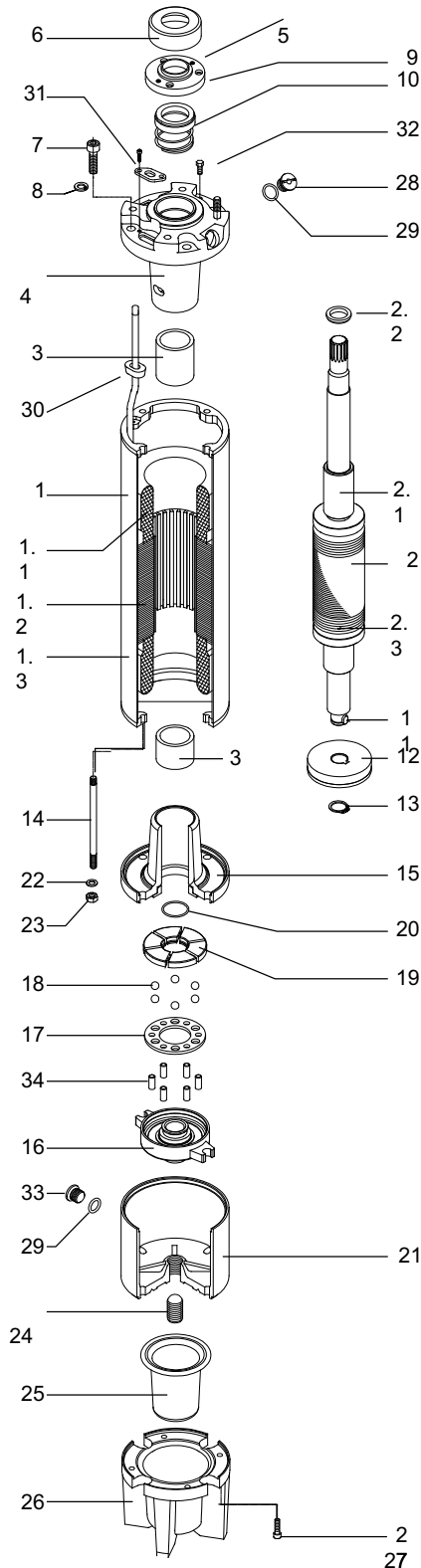

List of Components

No	Part Name	Material
1	Stator	-
1.1	Winding wire	Copper
1.2	Stator package	M350 / Magnetic Seal
1.3	Stator shell	AISI 304
2	Rotor	-
2.1	Shaft sleeve	Coated CrNi
2.2	Balance ring	St 37
2.3	Copper ring	Cu
3	Radial bearing	Carbon
4	Upper bearing body	GG20-22
5	Bushing	Bronze
6	Slinger (sand guard)	NBR_EPDM
7	Hexagon socket cap screws	Inox
8	Copper ring	Cu
9	Cover seal	AISI 420
10	Mechanical seal	Seramic Carbon
11	Axial thrust bearing key	AISI 420
12	Axial thrust bearing	Carbon With Antimony
13	Retaining ring	St 37
14	Tie rod	Inox
15	Lower bearing body	GG20-22
16	Thrust bearing support	GG20-22
17	Ball holder	St 37 (Coated Cr+3)
18	Thrust bearing ball	Inox
19	Tilting pads	AISI 420
20	O-ring	NBR 70
21	Thrust bearing body	GG20
22	Copper ring	Cu
23	Nut	Inox
24	Screw (thrust bearing base)	Inox
25	Membrane	NBR-EPDM
26	Membrane body	GG22
27	Hexagon socket cap screws	Inox
28	Check-valve	Bronze
29	O-ring	NBR 70
30	Cable seal	NBR
31	Seal cover	AISI 304
32	Nut	Inox
33	Plush (r 3/8")	Bronze
34	Ball holder pins	Inox

VSM1.06/4.0-3PH.F50.V380-DCX

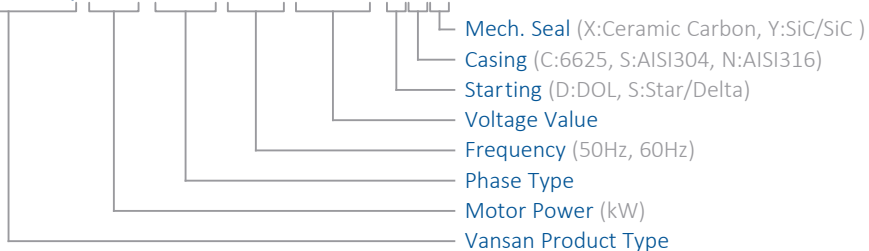

VSM 1.06 (50 Hz)

Type	P _N		Axial Load kN	Voltage V	n _N rpm	I _N A	I _A A	Efficiency (% load)			Cos Φ (% load)			TN Nm	TA Nm	Weight Kg
	HP	kW						50	75	100	50	75	100			
VSM1.06/4.0-3ph.f50.V380-DCX	5,5	4	20	380	2850	9,2	34,0	78,5	80,3	79,0	0,75	0,82	0,83	13,4	18,0	40,5
VSM1.06/5.5-3ph.f50.V380-DCX	7,5	5,5	20	380	2770	12,4	48,0	78,5	80,3	78,3	0,80	0,83	0,86	18,8	28,7	42,5
VSM1.06/7.5-3ph.f50.V380-DCX	10	7,5	20	380	2840	16,5	69,0	77,7	80,5	80,2	0,76	0,83	0,86	25,0	44,2	48
VSM1.06/9.3-3ph.f50.V380-DCX	12,5	9,3	20	380	2840	20,3	94,6	79,6	81,8	80,5	0,76	0,83	0,87	31,2	56,0	50,5
VSM1.06/11.0-3ph.f50.V380-DCX	15	11	20	380	2840	23,6	90,0	80,3	82,6	81,0	0,77	0,82	0,87	37,0	70,0	55
VSM1.06/13.0-3ph.f50.V380-DCX	17,5	13	20	380	2860	27,6	145,2	79,8	82,3	81,5	0,80	0,84	0,87	43,5	85,0	59
VSM1.06/15.0-3ph.f50.V380-DCX	20	15	20	380	2845	32,1	181,0	80,1	82,6	81,5	0,79	0,85	0,87	50,3	98,0	61
VSM1.06/18.5-3ph.f50.V380-DCX	25	18,5	20	380	2860	40,5	246,0	79,4	82,3	82,0	0,77	0,82	0,85	61,6	137	68
VSM1.06/22.0-3ph.f50.V380-DCX	30	22	20	380	2850	47,5	279,0	81,2	83,2	82,2	0,78	0,84	0,86	73,6	157	74
VSM1.06/26.5-3ph.f50.V380-DCX	35	26,5	26	380	2850	57,9	338,0	81,7	83,7	82,5	0,76	0,81	0,84	88,7	193	79
VSM1.06/30.0-3ph.f50.V380-DCX	40	30	26,5	380	2870	64,5	412,0	80,2	82,9	83,0	0,77	0,83	0,85	99,2	239	88
VSM1.06/37.0-3ph.f50.V380-DCX	50	37	26,5	380	2860	80,0	478,0	80,3	82,8	83,0	0,75	0,81	0,85	124	248	137
VSM1.06/45.0-3ph.f50.V380-DCX	60	45	26,5	380	2850	96,5	520,0	81,6	83,7	83,0	0,77	0,83	0,85	151	286	150

VSM 1.06 (60 Hz)

Type	P _N		Axial Load kN	Voltage V	n _N rpm	I _N A	I _A A	Efficiency (% load)			Cos Φ (% load)			TN Nm	TA Nm	Weight Kg
	HP	kW						50	75	100	50	75	100			
VSM1.06/4.0-3ph.f60.V460-DCX	5,5	4	20	460	3470	7,8	32,0	71.1	75.9	77.7	0.73	0.79	0.83	10,9	18,1	40.5
				380	3465	9,4	38,7	71.1	75.9	77.7	0.73	0.79	0.83	11,0	18,4	
				220	3455	16,3	66,9	70.0	75.0	77.0	0.73	0.79	0.83	11,2	19,0	
VSM1.06/5.5-3ph.f60.V460-DCX	7,5	5,5	20	460	3430	9,8	52,5	73.5	78.6	80.0	0.79	0.83	0.88	15,2	29,2	42.5
				380	3425	11,9	63,6	73.5	78.6	80.0	0.79	0.83	0.88	15,3	29,5	
				220	3415	20,5	109,8	72.5	77.5	79.0	0.79	0.83	0.88	15,5	30,1	
VSM1.06/7.5-3ph.f60.V460-DCX	10	7,5	20	460	3460	14,2	75,0	69.6	75.6	78.1	0.74	0.81	0.85	20,5	44,8	48.0
				380	3455	17,2	90,8	69.6	75.6	78.1	0.74	0.81	0.85	20,6	45,1	
				220	3445	29,7	156,8	69.0	74.7	77.1	0.79	0.83	0.88	20,8	45,7	
VSM1.06/9.3-3ph.f60.V460-DCX	12,5	9,3	20	460	3480	16,9	103,0	72.0	77.5	79.5	0.75	0.82	0.87	25,5	57,0	50.5
				380	3475	20,5	124,7	72.0	77.5	79.5	0.75	0.82	0.87	25,6	57,3	
				220	3465	35,3	215,4	71.0	77.0	78.5	0.79	0.83	0.88	25,8	57,9	
VSM1.06/11.0-3ph.f60.V460-DCX	15	11	20	460	3490	18,0	97,2	72.6	78.1	85.5	0.75	0.81	0.90	30,1	71,0	55
				380	3485	21,8	117,7	72.6	78.1	85.5	0.75	0.81	0.90	30,2	71,3	
				220	3475	37,6	203,2	71.6	77.2	84.5	0.75	0.81	0.90	30,4	71,9	
VSM1.06/13.0-3ph.f60.V460-DCX	17,5	13	20	460	3495	23,2	157,0	72.1	77.7	79.9	0.77	0.82	0.87	35,6	85,0	59
				380	3490	28,1	190,1	72.1	77.7	79.9	0.77	0.82	0.87	35,7	85,3	
				220	3480	48,5	328,3	71.2	77.0	79.0	0.77	0.82	0.87	35,9	85,9	
VSM1.06/15.0-3ph.f60.V460-DCX	20	15	20	460	3485	26,4	195,0	72.3	77.9	80.1	0.77	0.81	0.86	41,1	98,0	61
				380	3480	32,0	236,1	72.3	77.9	80.1	0.77	0.81	0.86	41,2	98,3	
				220	3470	55,2	407,7	71.5	77.0	79.2	0.77	0.81	0.86	41,4	98,9	
VSM1.06/18.5-3ph.f60.V460-DCX	25	18,5	20	460	3490	34,1	265,0	71.8	77.5	80.0	0.74	0.80	0.85	50,5	138,0	68
				380	3485	41,3	320,8	71.8	77.5	80.0	0.74	0.80	0.85	50,6	138,3	
				220	3475	71,3	554,1	70.9	76.5	79.0	0.74	0.80	0.85	50,8	138,9	
VSM1.06/22.0-3ph.f60.V460-DCX	30	22	20	460	3485	39,5	300,0	74.4	79.3	81.1	0.75	0.80	0.86	60,2	157,0	74
				380	3480	47,8	363,2	74.4	79.3	81.1	0.75	0.80	0.86	60,3	157,3	
				220	3470	82,6	627,3	73.4	79.3	80.1	0.75	0.80	0.86	60,5	157,9	
VSM1.06/26.5-3ph.f60.V460-DCX	35	26,5	26	460	3480	47,1	363,0	74.8	79.7	81.5	0.74	0.80	0.87	72,5	193,0	79
				380	3475	57,0	439,4	74.8	79.7	81.5	0.74	0.80	0.87	72,6	193,3	
				220	3465	98,5	759,0	73.8	78.8	80.5	0.74	0.80	0.87	72,8	193,9	
VSM1.06/30.0-3ph.f60.V460-DCX	40	30	26,5	460	3490	55,6	444,0	73.1	78.4	80.7	0.74	0.80	0.84	81,6	240,0	88
				380	3485	67,3	537,5	73.1	78.4	80.7	0.74	0.80	0.84	81,7	240,3	
				220	3475	116,3	928,4	72.2	77.5	79.8	0.74	0.80	0.84	81,9	240,9	
VSM1.06/37.0-3ph.f60.V460-DCX	50	37	26,5	460	3480	69,0	516,0	73.4	78.6	80.8	0.70	0.78	0.83	100,7	249,0	137
				380	3475	83,5	624,6	73.4	78.6	80.8	0.70	0.78	0.83	100,8	249,3	
				220	3465	144,3	1078,9	73.5	77.7	79.9	0.70	0.78	0.83	101,0	249,9	
VSM1.06/45.0-3ph.f60.V460-DCX	60	45	26,5	460	3480	81,0	559,0	75.4	80.1	81.9	0.73	0.80	0.85	123,5	286,0	150
				380	3475	98,1	676,7	75.4	80.1	81.9	0.73	0.80	0.85	123,6	286,3	
				220	3465	169,4	1168,8	74.2	70.1	81.0	0.73	0.80	0.85	123,8	286,9	

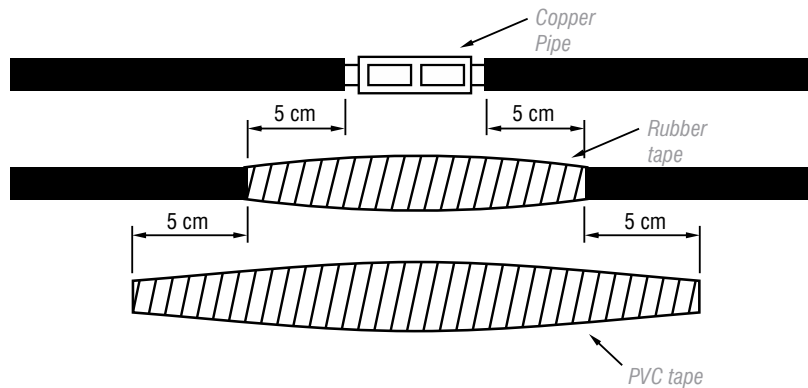

Power Cable Connection

Connection of the power cable that will be used along the well and until the control panel with the power cable on the motor must be done very carefully and by the professionals only. Unless the insulation after the connection is well done, short circuit might happen when the connection area is in the water.

Insulation of each cable should be stripped only as far as necessary to provide room for a stake type connector. Each individual joint should be taped with pvc tape, using two layers by wrapping tightly for eliminating airspaces as much as possible.

Total thickness of tape should be no less than the thickness of the cable insulation in order to prevent the smashing of the cables when the pump is lowered in the well.

Use Cooling Jacket

Cooling of submersible motors is provided with the flow of the water around it. That's why water flow around motors has vital importance during submersible pump installation. This flow rate depends on diameter and power of motor.

Most important factor of submersible motors' long service life is that the motor has to be cooled well. Required flow velocity around the motor is given in the table below for motors being cooled well enough.

If the motor will be installed in an open body of water (i.e pool) or diameter of the well is much bigger than the diameter of the motor, Flow Inducer Sleeve must be used to provide the flow velocities that are given in the table below, around the motor.

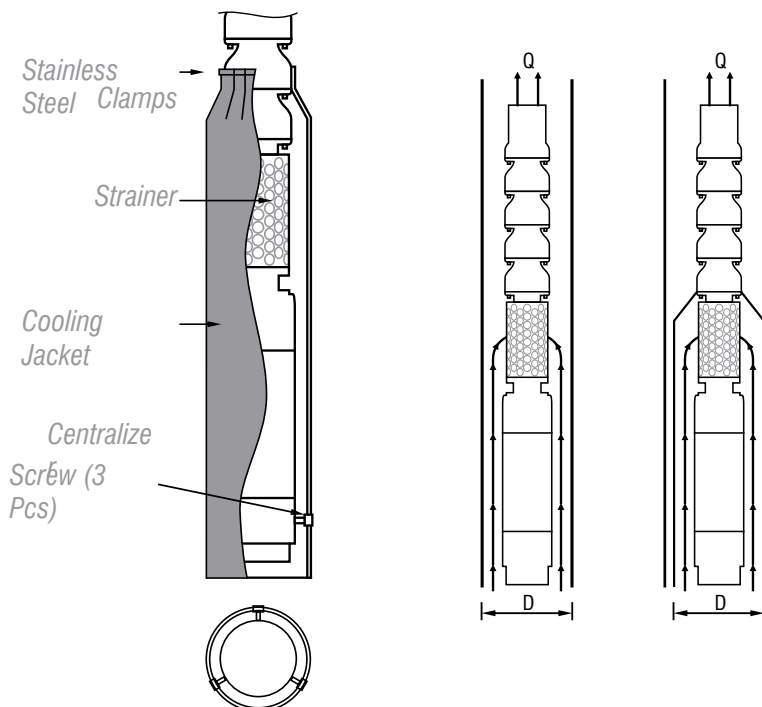

Insulation Resistance Test

All Vansan motors are applied insulation test under 3.000 V before shipment. Motors which have at least 2.000 megaohm test result are shipped. Insulation test results should be controlled before the installation and after connecting power cables as it is explained below. Meger tester's one probe should be touched to motor body and other probe should be touched to tip of each power cable to measure the insulation of each phase. If there is any short circuit in a phase, insulation value is 0 megaohm.

Under the normal operating conditions, a motor inside the well should have 2 megaohm insulation resistance. When the insulation resistance drops under 0.5 megaohm, there might be a insulation problem in winding. Test voltage should be at least 500 V DC.

After extending power cables with a joint, same test procedures should be also applied for insulation control while power cables are inside water. If insulation test result for any winding is lower than 100 megaohm, cable joint should be done again.



Use Frequency Converter and Soft Starter

These points listed below should be taken into consideration while operating submersible motors with frequency converter and soft starter.

Needed precautions should have been taken to protect your frequency converter from voltage fluctuations.

Flow rate around motor must be at least 0,15 m/s. If flow rate is not enough, flow inducer sleeve must be used to provide the needed flow rate.

In systems which are operated by frequency converter and soft starter, motor selection should be done as choosing next higher motor rate for pumps will provide long service life for motors.

Motors should be operated between 30-50 Hz with frequency converters. As the protective water layer can't be formed on thrust bearing at the lower frequencies, motor would get damaged.

Dual slope frequency converters should be used while using soft starter too.



Voltage Drop and Cable Power Loss

To determine the cable section it should be considered that the voltage drop must not exceed 3%. The formulas used for voltage drop calculation are given below.

Direct starter (1 cable)	$U_v = \frac{3,1 \times L \times I \times \cos\phi}{q \times U}$	$q = \frac{3,1 \times L \times I \times \cos\phi}{U_v \% \times U}$	L : Cable length (m) I : Current at nominal voltage q (A) : Conductor section (mm ²) cos φ : Power factor P _v : Power loss (%) U _v : Voltage drop (%) U : Nominal voltage (V)
Direct starter (2 cables in parallel)	$U_v = \frac{1,55 \times L \times I \times \cos\phi}{q \times U}$	$q = \frac{1,55 \times L \times I \times \cos\phi}{U_v \% \times U}$	
Star-delta starter	$U_v = \frac{2,1 \times L \times I \times \cos\phi}{q \times U}$	$q = \frac{2,1 \times L \times I \times \cos\phi}{U_v \% \times U}$	

The power loss along the feeling cable has to be calculated adjacent to:

$$P_v = \frac{U_v}{\cos^2\phi}$$

Energy Connection Schema

