



Stainless Steel Water Filled Submersible Motors

Made in Turkey



Catalogo 50/60 Hz

Stainless Steel Water Filled Submersible Motors

Standard Features

6" - 7" & 8" Sizes

Rewindable – Water Cooled

50 - 60 Hz / 380 - 460V

NEMA Mounting Dimensions

Stainless Steel Splined Shaft

Filter Check Valve

Same electrical data with Standard Version

*Available for Soft Starter & Frequency Converter drives CW
& CCW rotation*

*Max. ambient water temperature 30°C (optional up to 70°
C) Operates also horizontally*

Special Features

*All Stainless Steel (AISI 304), Corrosion Resistant Construction
(AISI 316 & AISI 904 Optimal)*

Meets Drinking Water Regulations

Enhanced Cooling Properties

Reasonable price difference with Standard Version

Easy to convert to AISI 316 or AISI 904 Construction

Replaceable Lead Connection (optional)

Applications

Excellent choice for submersible motor applications,
including:

Water Wells (Domestic, Agricultural,

Municipal) Sea Water

Mining

Fountains

Industrial

Drinking Water Pumping

**Heavy duty bearings with high thrust capacity**

Heavy duty bearings provides the option to revolve both sides, has the capacity to carry high thrust load.

**Water lubricated radial carbon bearings**

Radial carbon bearings, which have channels in its structure that makes it possible to get lubricated by water easily, provides precise bearing of rotor shaft at up and down.

**Chrome-plated bearing collet**

Chrome-plated and precisely machined bearing collets which are located in the radial bearings operating area, have great importance for bearing the rotor.

**Mechanical sealing system for high sand resistance and degree of protection: IP68**

Although mechanical seal is optionally used by other companies, it is always used by Vansan as a standard, to prevent sand and other particles to get in motors to provide long bearing life.

**Practical and easy-to-mount output power cable**

Connection of the power cable to body is made practically by cable seal and seal cover. Power cables can be changed easily without any damage.

**Pressure balancing checkvalve**

Pressure balancing checkvalve controls the pressure changes inside the motor. When the pressure increases, it throw water out of the motor. When the pressure drops, it filtrates the water inside well and gets it inside the motor by the help of this checkvalve to balance the pressure inside. That's why pressure differences inside motor never causes membrane under motor to blow up.



PT100 Overheating protection

By connecting the PT100 thermal sensors to the slot that is standardly placed on upper bearing body, motor temperature values can be easily measured.



Up-Thrust ring

Provides safe operation conditions for motor by absorbing Up-Thrust loads with it's machined surface and water channels on it.



Cable connection

Preventing the water inside the motor to run through the cable and reach connection parts of power cables by specially designed cable seals.



Adjustment screw

Standard shaft height can be precisely adjusted by the adjustment screw on the thrust bearing base.



Membrane

Membrane minimizes the expansion pressure that is caused by heating of cooling water's inside the motor



Slinger (sand guard)

Slinger helps to prevent the sand inside the water of the well entering in mechanical seal and through mechanical seal to inside of the motor.

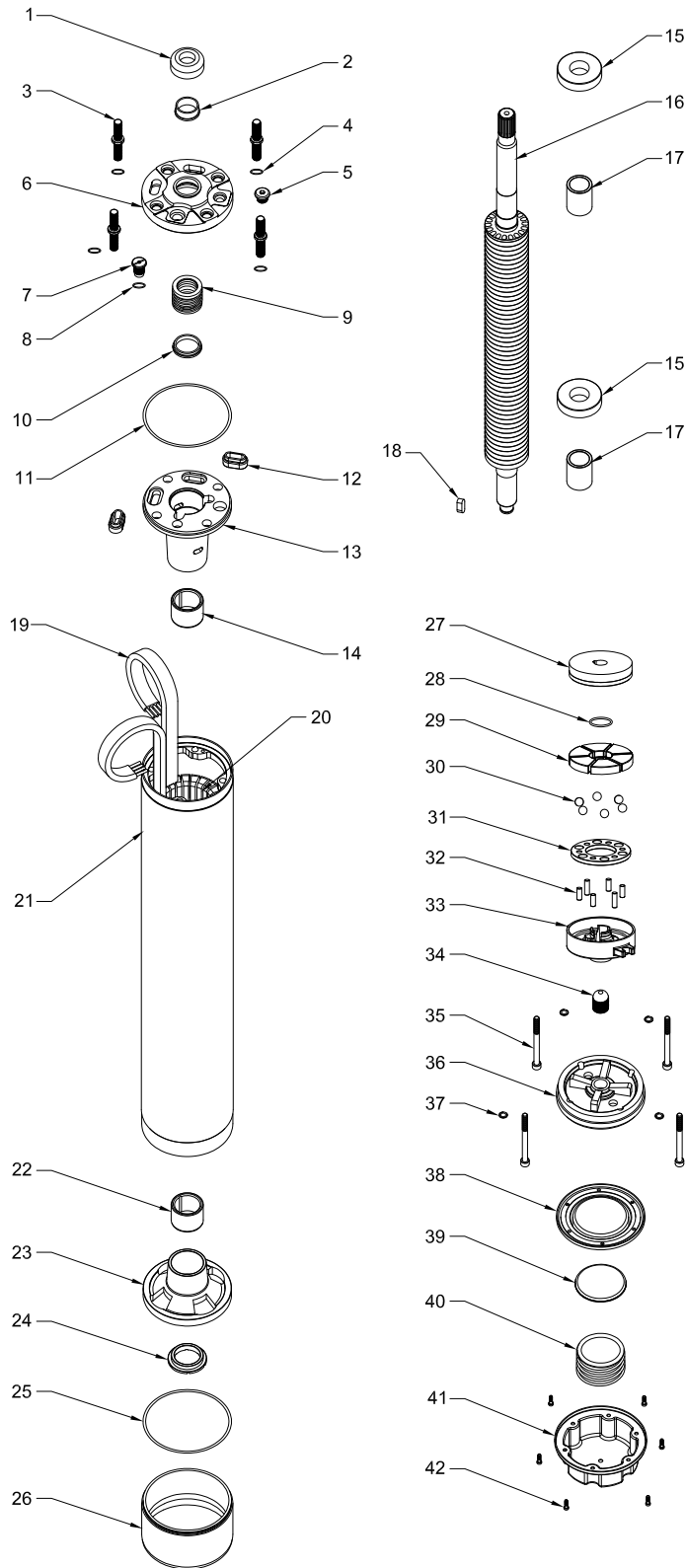

Part List

No	Part Name	Material
1	Slinger (Sand Guard)	NBR_EPDM
2	Inner Ring	Bronz
3	Stud	AISI 304
4	O-ring	NBR
5	Plug	AISI 304
6	Upper Connection Flange	AISI 304
7	Check Valve	AISI 304
8	O-ring	NBR
9	Mechanical Seal	SiC-SiC
10	Support Ring	-
11	O-ring	NBR
12	Cable Seal	NBR
13	Upper Bearing Body	GG25
14	Radial Bearing	Carbon
15	Balance Ring	CK 45
16	Rotor	-
17	Shaft Sleeve	St 37 (Coated CrNi)
18	Key	AISI 420
19	Energy Cable (Lead)	PVC
20	Stator Stack	M530/Magnetic Steel
21	Stator	-
22	Radial Bearing	Carbon
23	Lower Bearing Body	GG25
24	Up Thrust Bearing	Bronze
25	O-ring	NBR
26	Axial Bearing Sheet	AISI 304
27	Thrust Disc	Carbon With Antimony
28	O-ring	NBR
29	Axial Thrust Segments	AISI 420
30	Ball	Inox
31	Ball Holder	St 37 (Coated Cr+3)
32	Pins	Inox
33	Axial Thrust Bearing Support	GG25
34	Screw	Inox
35	Bolt	AISI 304
36	Axial Bearing Body Flange	GG25
37	Copper Ring	Copper
38	Membrane	NBR
39	Support Sheet	AISI 304
40	Spring	AISI 304
41	Membrane Cover	AISI 304
42	Bolt	AISI 304

VSM.3S.8 / 250

Motor power (HP)
 Motor diameter
 Motor type



Stainless Steel Sub. Motors

Type	Dimension	kW	HP	D.O.L.		Wye-Delta		Ax.Thrust	Start	Length	Weight
				mm ²	n	mm ²	n	kN	start/h	mm	kg
VSM.3S.6/5.5	6"	4	5,5	3x2,5	1	3x2,5	2	20	20	594	38
VSM.3S.6/7.5	6"	5,5	7,5	3x2,5	1	3x2,5	2	20	20	623	41,5
VSM.3S.6/10	6"	7,5	10	3x2,5	1	3x2,5	2	20	20	703	48
VSM.3S.6/12.5	6"	9,3	12,5	3x2,5	1	3x2,5	2	20	20	743	53
VSM.3S.6/15	6"	11	15	3x4	1	3x4	2	20	20	796	58
VSM.3S.6/17.5	6"	13	17,5	3x4	1	3x4	2	20	20	856	63
VSM.3S.6/20	6"	15	20	3x4	1	3x4	2	20	20	918	70
VSM.3S.6/25	6"	19	25	3x4	1	3x4	2	20	20	951	74
VSM.3S.6/30	6"	22	30	3x6	1	3x6	2	20	20	1.051	85
VSM.3S.6/35	6"	27	35	3x6	1	3x6	2	26,5	15	1.166	96
VSM.3S.6/40	6"	30	40	3x6	2	3x6	2	26,5	15	1.196	101
VSM.3S.6/50	6"	37	50	3x6	2	3x6	2	26,5	15	1.296	108
VSM.3S.6/60	6"	45	60	3x6	2	3x6	2	26,5	15	1.296	108
VSM.3S.7/30	7"	22	30	3x10	1	3x10	2	45	17	842	83
VSM.3S.7/35	7"	26,5	35	3x10	1	3x10	2	45	17	882	88
VSM.3S.7/40	7"	30	40	3x10	1	3x10	2	45	17	922	100
VSM.3S.7/50	7"	37	50	3x10	1	3x10	2	45	17	1.001	110
VSM.3S.7/60	7"	45	60	3x16	1	3x16	2	45	17	1.081	124
VSM.3S.7/70	7"	52	70	3x16	1	3x16	2	45	17	1.160	135
VSM.3S.7/75	7"	55	75	3x16	1	3x16	2	45	17	1.160	135
VSM.3S.8/40	8"	30	40	3x10	1	3x10	2	45	15	948	125
VSM.3S.8/50	8"	37	50	3x10	1	3x10	2	45	15	1.008	134
VSM.3S.8/60	8"	45	60	3x10	1	3x10	2	45	15	1.093	148
VSM.3S.8/70	8"	52	70	3x16	1	3x16	2	45	15	1.178	166
VSM.3S.8/75	8"	55	75	3x16	1	3x16	2	45	15	1.178	166
VSM.3S.8/80	8"	60	80	3x16	1	3x16	2	45	15	1.233	181
VSM.3S.8/90	8"	67	90	3x16	1	3x16	2	45	15	1.258	186
VSM.3S.8/100	8"	75	100	3x16	1	3x16	2	45	15	1.283	191
VSM.3S.8/110	8"	81	110	3x16	2	3x16	2	55	15	1.363	201
VSM.3S.8/125	8"	92	125	3x16	2	3x16	2	55	10	1.428	208

3S Motor Dimensions

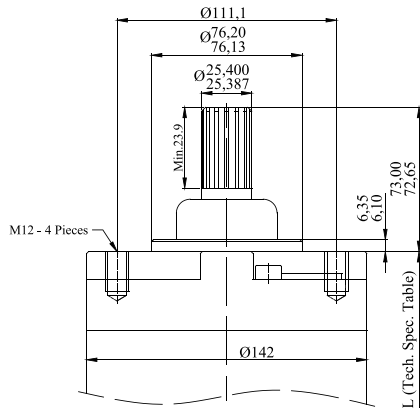

6" Motor

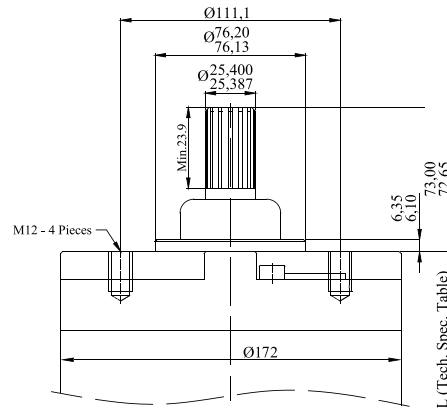

7" Motor

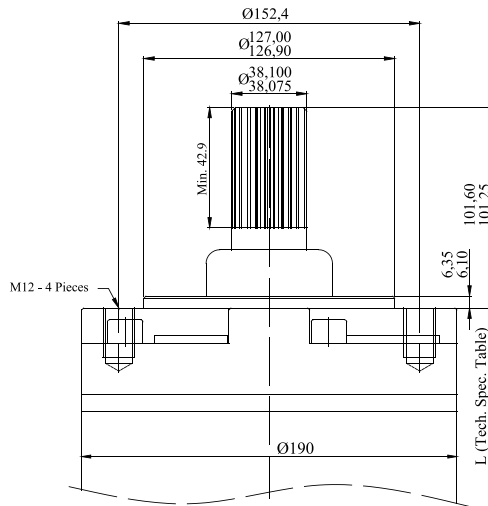

8" Motor

Cable Dimensions

Cable Type	Thickness	Width	Diameter
mm ²	(t) mm	(w) mm	(d) mm
3x2,5	7	14,7	3,8
3x4	7,5	16,5	4,1
3x6	9	19,5	4,8
3x10	10	24	6,3
3x16	11,5	27,6	7,35
3x25	13	31,5	9,2

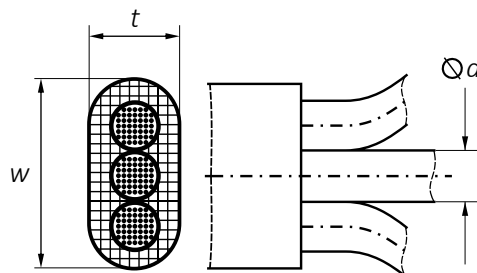

VSM 6" (50Hz) 6" Submersible Motors (3S)

Type	R _N		Axial Load kN	Voltage V	n _N rpm	I _N A	I _A A	Efficiency (% load)			Cos Φ (% load)		
	HP	kW						50	75	100	50	75	100
VSM.3S.6/5.5	5,5	4	20	380	2770	10,2	39,4	68	72	72	59,0	67	82
VSM.3S.6/7.5	7,5	5,5	20	380	2780	13,3	52,7	74	74	76	59,0	67	82
VSM.3S.6/10	10	7,5	20	380	2790	17,2	66,4	79	80	80	59,0	67	82
VSM.3S.6/12.5	12,5	9,3	20	380	2850	20,8	80,3	80	81	81	59,0	67	82
VSM.3S.6/15	15	11	20	380	2810	23,7	91,6	82	83	83	63,0	71	84
VSM.3S.6/17.5	17,5	13	20	380	2820	28,7	110,9	81	82	82	61,0	69	83
VSM.3S.6/20	20	15	20	380	2850	33,1	127,9	80	81	81	61,0	69	83
VSM.3S.6/25	25	18,5	20	380	2850	41,8	161,6	81	82	82	57,5	66	81
VSM.3S.6/30	30	22	20	380	2860	48,5	187,6	82	83	83	59,0	67	82
VSM.3S.6/35	35	26,5	26,5	380	2870	56,4	217,9	83	84	84	61,0	69	83
VSM.3S.6/40	40	30	26,5	380	2880	64,6	249,7	83	84	84	61,0	69	83
VSM.3S.6/50	50	37	26,5	380	2890	79,7	315,6	81	82	84	61,0	69	83
VSM.3S.6/60	60	45	26,5	380	2900	98,0	398,9	79	81	82	61,0	69	83

VSM 7" (50Hz) 7" Submersible Motors (3S)

Type	P _N		Axial Load	Voltage	n _N	I _N	I _A	Efficiency (% load)			Cos Φ (% load)		
	HP	kW						kN	V	rpm	A	A	50
VSM.3S.7/30	30	22	45	380	2880	46,3	235	83	84	84	76	82	86
VSM.3S.7/35	35	26,5	45	380	2880	55,1	279	84	85	85	76	82	86
VSM.3S.7/40	40	30	45	380	2880	62,4	312	85	86	85	66	82	86
VSM.3S.7/50	50	37	45	380	2880	74,3	377	85	86	86	78	85	88
VSM.3S.7/60	60	45	45	380	2870	90,3	459	85	86	86	76	84	88
VSM.3S.7/70	70	52	45	380	2860	105,6	537	85	86	86	78	83	87
VSM.3S.7/75	75	55	45	380	2900	112,9	554	85	85	84	76	84	88

VSM 8" (50Hz) 8" Submersible Motors (3S)

Type	P _N		Axial Load	Voltage	n _N	I _N	I _A	Efficiency (% load)			Cos Φ (% load)		
	HP	kW						kN	V	rpm	A	A	50
VSM.3S.8/40	40	30	45	380	2850	61,7	239	82	83	83	74,5	80	89
VSM.3S.8/50	50	37	45	380	2860	74,3	287	84	85	85	74,5	80	89
VSM.3S.8/60	60	45	45	380	2860	90,4	349	84	85	85	74,5	80	89
VSM.3S.8/70	70	52	45	380	2850	103,3	399	84	85	85	77,0	83	90
VSM.3S.8/75	75	55	45	380	2850	110,5	427	83	84	84	77,0	83	90
VSM.3S.8/80	80	60	45	380	2850	119,1	460	85	86	86	74,5	80	89
VSM.3S.8/90	90	67	45	380	2850	134,6	520	84	85	85	74,5	80	89
VSM.3S.8/100	100	75	45	380	2850	150,7	582	83	84	84	77,0	83	90
VSM.3S.8/110	110	81	55	380	2855	162,7	629	84	85	85	74,5	80	89
VSM.3S.8/125	125	92	55	380	2820	184,8	714	84	85	85	74,5	80	89

VSM 6" (60Hz) 6" Submersible Motors (3S)

Type	P _N		Axial Load kN	Voltage V	n _N rpm	I _N A	I _A A	Efficiency (% load)			Cos φ (% load)		
	HP	kW						50	75	100	50	75	100
VSM.3S.6/5.5	5,5	4	20	460	3350	8,4	44	69	70	70	65	74	85
VSM.3S.6/7.5	7,5	5,5	20	460	3360	11,3	59	71	72	72	65	74	85
VSM.3S.6/10	10	7,5	20	460	3380	14,2	73	77	78	78	65	74	85
VSM.3S.6/12.5	12,5	9,3	20	460	3390	17,4	90		78	79	65	74	85
VSM.3S.6/15	15	11	20	460	3400	19,6	101	80	81	81	67	76	87
VSM.3S.6/17.5	17,5	13	20	460	3410	23,4	121	80	81	81	66	75	86
VSM.3S.6/20	20	15	20	460	3440	27,3	141	79	80	80	66	75	86
VSM.3S.6/25	25	18,5	20	460	3450	34,5	178	79	80	80	64	73	84
VSM.3S.6/30	30	22	20	460	3460	40,1	207	80	81	81	65	74	85
VSM.3S.6/35	35	26,5	26,5	460	3470	47,1	242	81	82	82	66	75	86
VSM.3S.6/40	40	30	26,5	460	3480	53,4	272	81	82	82	66	75	86
VSM.3S.6/50	50	37	26,5	460	3490	66,6	341	80	81	81	66	75	86
VSM.3S.6/60	60	45	26,5	460	3500	75,3	427	81	82	82	66	75	86

VSM 7" (60Hz) 7" Submersible Motors (3S)

Type	P _N		Axial Load	Voltage	n _N	I _N	I _A	Efficiency (% load)			Cos Φ (% load)		
	HP	kW						kN	V	rpm	A	A	50
VSM.3S.7/30	30	22	45	460	3480	38,2	194	82	83	83	77	83	87
VSM.3S.7/35	35	26,5	45	460	3480	45,0	230	83	84	84	77	83	87
VSM.3S.7/40	40	30	45	460	3480	52,1	260	84	85	84	77	83	87
VSM.3S.7/50	50	37	45	460	3480	61,4	311	84	85	85	79	86	89
VSM.3S.7/60	60	45	45	460	3470	74,7	379	84	85	85	77	85	89
VSM.3S.7/70	70	52	45	460	3460	87,2	443	84	85	85	79	84	88
VSM.3S.7/75	75	55	45	460	3460	93,0	473	84	85	85	79	84	88

VSM 8" (60Hz) 8" Submersible Motors (3S)

Type	P _N		Axial Load	Voltage	n _N	I _N	I _A	Efficiency (% load)			Cos Φ (% load)		
	HP	kW						kN	V	rpm	A	A	50
VSM.3S.8/40	40	30	45	460	3450	51,0	258	83	83	82	82	86	90
VSM.3S.8/50	50	37	45	460	3460	61,4	308	85	85	84	82	86	90
VSM.3S.8/60	60	45	45	460	3460	74,8	382	85	85	84	82	86	90
VSM.3S.8/70	70	52	45	460	3450	85,3	431	85	85	84	83	87	91
VSM.3S.8/75	75	55	45	460	3450	90,2	458	85	85	84	83	87	91
VSM.3S.8/80	80	60	45	460	3450	99,6	509	85	85	84	82	86	90
VSM.3S.8/90	90	67	45	460	3450	111,2	563	85	85	84	82	86	90
VSM.3S.8/100	100	75	45	460	3450	123,1	625	85	85	84	82	86	91
VSM.3S.8/110	110	81	55	460	3430	134,4	681	85	85	84	82	86	90
VSM.3S.8/125	125	92	55	460	3430	152,8	770	85	85	84	82	86	90

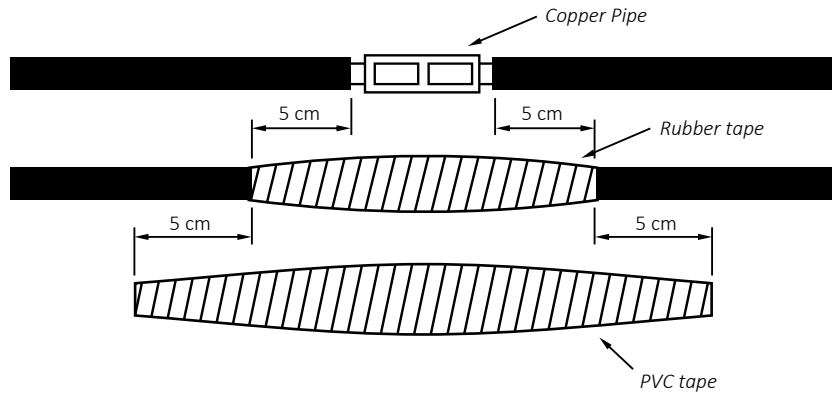

Power Cable Connection

Connection of the power cable that will be used along the well and until the control panel with the power cable on the motor must be done very carefully and by the professionals only. Unless the insulation after the connection is well done, short circuit might happen when the connection area is in the water.

Insulation of each cable should be stripped only as far as necessary to provide room for a stake type connector. Each individual joint should be taped with pvc tape, using two layers by wrapping tightly for eliminating airspaces as much as possible.

Total thickness of tape should be no less than the thickness of the cable insulation in order to prevent the smashing of the cables when the pump is lowered in the well.

Use Cooling Jacket

Cooling of submersible motors is provided with the flow of the water around it. That's why water flow around motors has vital importance during submersible pump installation. This flow rate depends on diameter and power of motor.

Most important factor of submersible motors' long service life is that the motor has to be cooled well. Required flow velocity around the motor is given in the table below for motors being cooled well enough.

If the motor will be installed in an open body of water (i.e pool) or diameter of the well is much bigger than the diameter of the motor, Flow Inducer Sleeve must be used to provide the flow velocities that are given in the table below, around the motor.

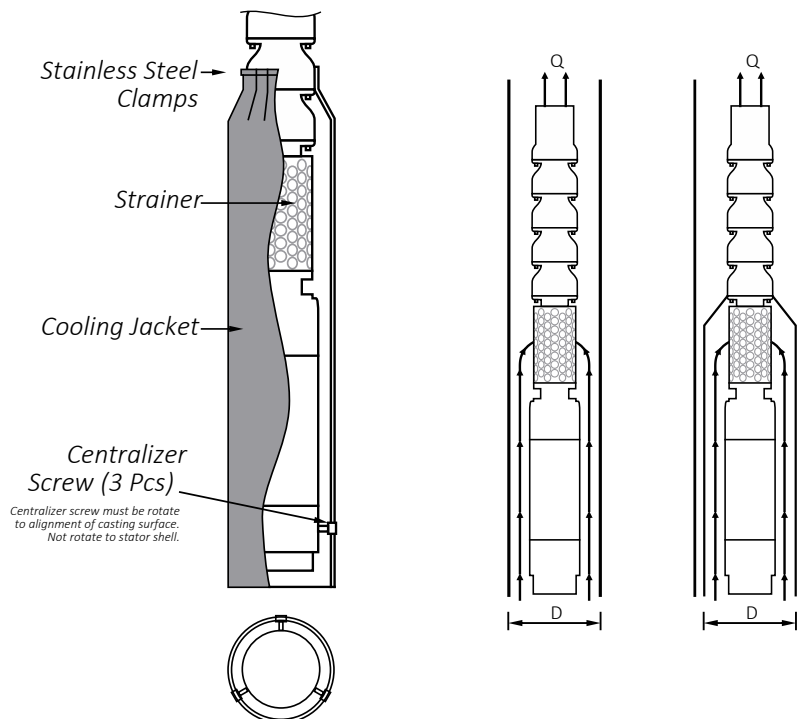

Insulation Resistance Test

All Vansan motors are applied insulation test under 3.000 V before shipment. Motors which have at least 2.000 megaohm test result are shipped. Insulation test results should be controlled before the installation and after connecting power cables as it is explained below. Meger tester's one probe should be touched to motor body and other probe should be touched to tip of each power cable to measure the insulation of each phase. If there is any short circuit in a phase, insulation value is 0 megaohm.

Under the normal operating conditions, a motor inside the well should have 2 megaohm insulation resistance. When the insulation resistance drops under 0.5 megaohm, there might be a insulation problem in winding. Test voltage should be at least 500 V DC.

After extending power cables with a joint, same test procedures should be also applied for insulation control while power cables are inside water. If insulation test result for any winding is lower than 100 megaohm, cable joint should be done again.



Use Frequency Converter and Soft Starter

These points listed below should be taken into consideration while operating submersible motors with frequency converter and soft starter.

Needed precautions should have been taken to protect your frequency converter from voltage fluctuations.

Flow rate around motor must be at least 0,15 m/s. If flow rate is not enough, flow inducer sleeve must be used to provide the needed flow rate.

In systems which are operated by frequency converter and soft starter, motor selection should be done as choosing next higher motor rate for pumps will provide long service life for motors.

Motors should be operated between 30-50 Hz with frequency converters. As the protective water layer can't be formed on thrust bearing at the lower frequencies, motor would get damaged.

Dual slope frequency converters should be used while using soft starter too.



Voltage Drop and Cable Power Loss

To determine the cable section it should be considered that the voltage drop must not exceed 3%. The formulas used for voltage drop calculation are given below.

Direct starter (1 cable)	$U_v = \frac{3,1 \times L \times I \times \cos\varphi}{q \times U}$	$q = \frac{3,1 \times L \times I \times \cos\varphi}{U_v \% \times U}$	L : Cable length (m) I : Current at nominal voltage (A) q : Conductor section (mm ²) cosφ : Power factor P _v : Power loss (%) U _v : Voltage drop (%) U : Nominal voltage (V)
Direct starter (2 cables in parallel)	$U_v = \frac{1,55 \times L \times I \times \cos\varphi}{q \times U}$	$q = \frac{1,55 \times L \times I \times \cos\varphi}{U_v \% \times U}$	
Star-delta starter	$U_v = \frac{2,1 \times L \times I \times \cos\varphi}{q \times U}$	$q = \frac{2,1 \times L \times I \times \cos\varphi}{U_v \% \times U}$	

The power loss along the feeling cable has to be calculated adjacent to:

$$P_v = \frac{U_v}{\cos^2\varphi}$$

Energy Connection Schema

