



6",8",10" High Temperature Water Filled Submersible Motors

Made in Turkey



Catalogue 50 / 60 Hz



Rewindable Water Filled Submersible Motors

Standard Features

High quality PE2+PA winding wires

High efficiency provides operation cost savings

Water coolant system

Flange with NEMA standards

Stainless steel shaft

Optional high corrosion resistive materials (AISI 304 - AISI 316 - Duplex - Bronze)

Maximum ambient water temperature 50°C (70°C is optional)

Standard voltage 380/460V - 50/60Hz (Allowable voltage tolerance \pm 10.%)

Variable operation revolutions by frequency convertor (over 30Hz)

Availability to be operated by Soft-Starter

CW & CCW direction of rotation.

Rewindable Vansan Motors provides long service life.

Our motors can be operated horizontally in pools and wells which are not deep enough

**Heavy duty bearings with high thrust capacity**

Heavy duty bearings provides the option to revolve both sides, has the capacity to carry high thrust load.

**Water lubricated radial carbon bearings**

Radial carbon bearings, which have channels in its structure that makes it possible to get lubricated by water easily, provides precise bearing of rotor shaft at up and down.

**Chrome-plated bearing collet**

Chrome-plated and precisely machined bearing collets which are located in the radial bearings operating area, have great importance for bearing the rotor.

**Mechanical sealing system for high sand resistance and degree of protection: IP68**

Although mechanical seal is optionally used by other companies, it is always used by Vansan as a standard, to prevent sand and other particles to get in motors to provide long bearing life.

**Practical and easy-to-mount output power cable**

Connection of the power cable to body is made practically by cable seal and seal cover. Power cables can be changed easily without any damage.

**Pressure balancing checkvalve**

Pressure balancing checkvalve controls the pressure changes inside the motor. When the pressure increases, it throw water out of the motor. When the pressure drops, it filtrates the water inside well and gets it inside the motor by the help of this checkvalve to balance the pressure inside. That's why pressure differences inside motor never causes membrane under motor to blow up.

**PT100 Overheating protection**

By connecting the PT100 thermal sensors to the slot that is standardly placed on upper bearing body, motor temperature values can be easily measured.

**Up-Thrust ring**

Provides safe operation conditions for motor by absorbing Up-Thrust loads with it's machined surface and water channels on it.

**Cable connection**

Preventing the water inside the motor to run through the cable and reach connection parts of power cables by specially designed cable seals.

**Adjustment screw**

Standard shaft height can be precisely adjusted by the adjustment screw on the thrust bearing base.

**Membrane**

Membrane minimizes the expansion pressure that is caused by heating of cooling water's inside the motor

**Slinger (sand guard)**

Slinger helps to prevent the sand inside the water of the well entering in mechanical seal and through mechanical seal to inside of the motor.

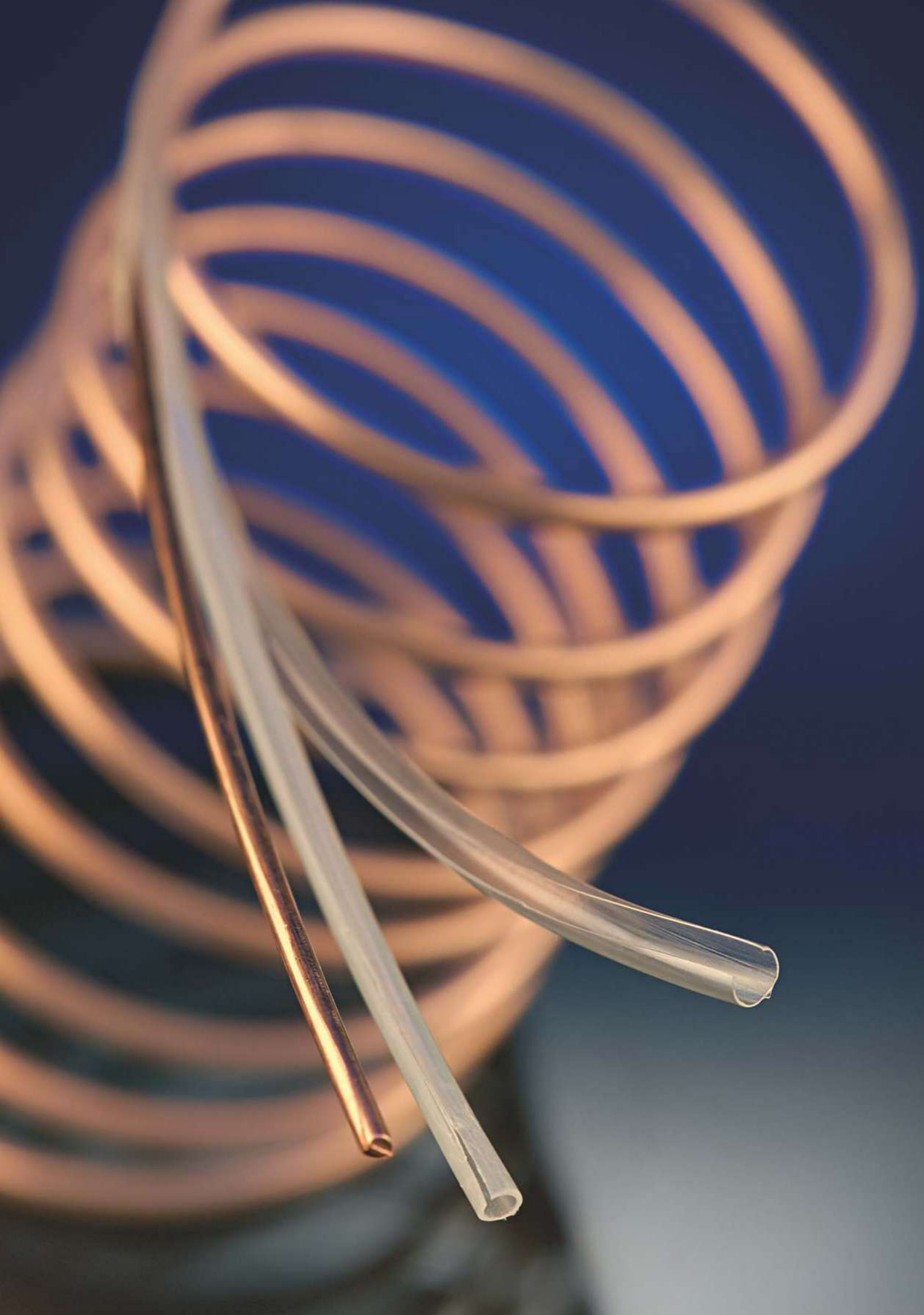

“PE2+PA Winding Wire”

- ✓ Perfect performance up to 50°C ambient temp.,
- ✓ Longer Life
- ✓ High resistance against voltage fluctuation,
- ✓ Gives more safety factor than standard motors

Sistema's submersible motors get their power from the PE2+PA winding wire used as standard. This wire, consisting of a single copper conductor, has a very high insulation resistance. PE2 (Polyethylene) provides electrical isolation, PA (Polyamide) provides mechanical protection. Increased heat resistance is achieved by cross-linking of polyethylene. In this way, Vansan submersible motors offers superior performance at high voltage and temperatures up to 50 °C. At the same time it ensures trouble-free operation and a long service life of the motors for many years.

Technical Data

Tensile Strength	Standard: IEC 60811-1-1	23°C (±5)	≥ 10 N/mm ²
Elongation	Standard: IEC 60811-1-1	23°C (±5)	≥ 100 %
Dielectric constant	Standard: DIN 53483	20°C / 800 Hz	2,3
Specific insulation resistance	Standard: IEC 60093	20°C	10 Ω cm
Dielectric breakdown strength	Standard: DIN VDE 0303-21	20°C/50 Hz	70 kV/mm
Tensile strength after aging		80°C / 7x24 saat	≥ 10 N/mm ²
Elongation at break after aging		80°C / 7x24 saat	≥ 100 %

Part List

No	Part Name	Material
1	<i>Stator</i>	-
1.1	<i>Winding wire</i>	PE2 / PA
1.2	<i>Stator package</i>	M350 / Magnetic Seal
1.3	<i>Stator shell</i>	AISI 304
2	<i>Rotor</i>	-
2.1	<i>Shaft sleeve</i>	St 37 (Coated CrNi)
2.2	<i>Balance ring</i>	St 37
2.3	<i>Copper ring</i>	Cu
3	<i>Radial bearing</i>	Carbon
4	<i>Upper bearing body</i>	GG20-22
5	<i>Bushing</i>	Bronze
6	<i>Slinger (sand guard)</i>	NBR_EPDM
7	<i>Hexagon socket cap screws</i>	Inox
8	<i>Copper ring</i>	Cu
9	<i>Cover seal</i>	AISI 420
10	<i>Mechanical seal</i>	Seramic Carbon
11	<i>Axial thrust bearing key</i>	AISI 420
12	<i>Axial thrust bearing</i>	Carbon With Antimony
13	<i>Retaining ring</i>	St 37
14	<i>Tie rod</i>	Inox
15	<i>Lower bearing body</i>	GG20-22
16	<i>Thrust bearing support</i>	GG20-22
17	<i>Ball holder</i>	St 37 (Coated Cr+3)
18	<i>Thrust bearing ball</i>	Inox
19	<i>Tilting pads</i>	AISI 420
20	<i>O-ring</i>	NBR 70
21	<i>Thrust bearing body</i>	GG20
22	<i>Copper ring</i>	Cu
23	<i>Nut</i>	Inox
24	<i>Screw (thrust bearing base)</i>	Inox
25	<i>Membrane</i>	NBR-EPDM
26	<i>Membrane body</i>	GG22
27	<i>Hexagon socket cap screws</i>	Inox
28	<i>Check-valve</i>	Bronze
29	<i>O-ring</i>	NBR 70
30	<i>Cable seal</i>	NBR
31	<i>Seal cover</i>	AISI 304
32	<i>Nut</i>	Inox
33	<i>Plush (r 3/8")</i>	Bronze
34	<i>Ball holder pins</i>	Inox

Technical Drawing

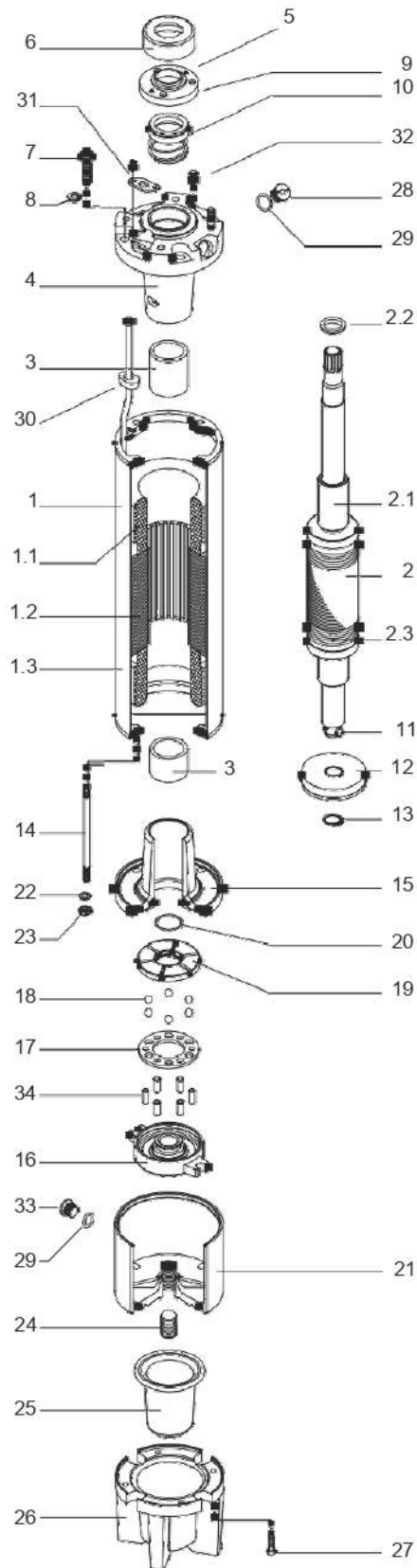



Rewindable Sub. Motors

Type	Dimension	kW	HP	D.O.L.		Wye-Delta		Ax. Thrust	Start	Length	Weight
				mm ²	n	mm ²	n	kN	start/h	mm	kg
VSM 6/5.5	6"	4	5.5	3x2,5	1	3x2,5	2	20	20	649	40
VSM 6/7.5	6"	5,5	7.5	3x2,5	1	3x2,5	2	20	20	649	40
VSM 6/10	6"	7,5	10	3x2,5	1	3x2,5	2	20	20	678	43,5
VSM 6/12.5	6"	9,3	12,5	3x2,5	1	3x2,5	2	20	20	758	50
VSM 6/15	6"	11	15	3x4	1	3x4	2	20	20	800	55
VSM 6/17.5	6"	13	17,5	3x4	1	3x4	2	20	20	851	60
VSM 6/20	6"	15	20	3x4	1	3x4	2	20	20	911	65
VSM 6/25	6"	18,5	25	3x6	1	3x4	2	20	20	973	72
VSM 6/30	6"	22	30	3x6	1	3x4	2	20	20	1.006	76
VSM 6/35	6"	26,5	35	3x10	1	3x6	2	26,5	15	1.106	87
VSM 6/40	6"	30	40	3x16	1	3x6	2	26,5	15	1.217	98
VSM 6/50	6"	37	50	3x16	1	3x6	2	26,5	15	1.247	103
VSM 6/60	6"	45	60	3x16	1	3x6	2	26,5	15	1.347	110
VSM 7/30	7"	22	30	3x6	1	3x4	2	45	17	840	81
VSM 7/35	7"	26,5	35	3x10	1	3x6	2	45	17	890	86
VSM 7/40	7"	30	40	3x16	1	3x6	2	45	17	940	91
VSM 7/50	7"	37	50	3x16	1	3x6	2	45	17	980	103
VSM 7/60	7"	45	60	3x16	1	3x10	2	45	17	1.060	113
VSM 7/70	7"	52	70	3x16	1	3x10	2	45	17	1.139	127
VSM 7/75	7"	55	75	3x16	1	3x10	2	45	17	1.218	138
VSM 7/80	7"	60	80	3x16	1	3x10	2	45	17	1.250	149
VSM 7/90	7"	67	90	3x16	1	3x10	2	45	17	1.282	160
VSM 8/40	8"	30	40	3x16	1	3x10	2	45	15	996	120
VSM 8/50	8"	37	50	3x16	1	3x10	2	45	15	1.056	129
VSM 8/60	8"	45	60	3x16	1	3x10	2	45	15	1.116	138
VSM 8/70	8"	52	70	3x16	1	3x10	2	45	15	1.201	152
VSM 8/75	8"	55	75	3x16	1	3x10	2	45	15	1.286	170
VSM 8/80	8"	60	80	3x16	1	3x10	2	45	15	1.286	170
VSM 8/90	8"	67	90	3x16	1	3x10	2	45	15	1.341	185
VSM 8/100	8"	75	100	3x25	1	3x16	2	45	15	1.366	186
VSM 8/110	8"	81	110	3x25	1	3x16	2	55	15	1.391	195
VSM 8/125	8"	92	125	3x25	1	3x16	2	55	10	1.471	210
VSM 8/135	8"	100	135	3x25	1	3x16	2	55	10	1.536	225
VSM 8/150	8"	110	150	3x25	1	3x16	2	55	10	1.601	235
VSM 10/100	10"	75	100	3x25	1	3x16	2	55	10	1.250	200
VSM 10/110	10"	81	110	3x25	1	3x25	2	75	10	1.310	228
VSM 10/125	10"	92	125	3x25	1	3x25	2	75	10	1.370	256
VSM 10/150	10"	110	150	3x35	1	3x25	2	75	10	1.430	284
VSM 10/175	10"	129	175	3x35	2	3x25	2	75	10	1.510	311
VSM 10/200	10"	147	200	3x35	2	3x25	2	75	10	1.610	338
VSM 10/225	10"	166	225	3x35	2	3x25	2	75	10	1.740	370
VSM 10/250	10"	185	250	-	-	3x35	2	75	10	1.820	400
VSM 10/300	10"	220	300	-	-	3x35	2	75	10	1.820	405

Motors Dimensions

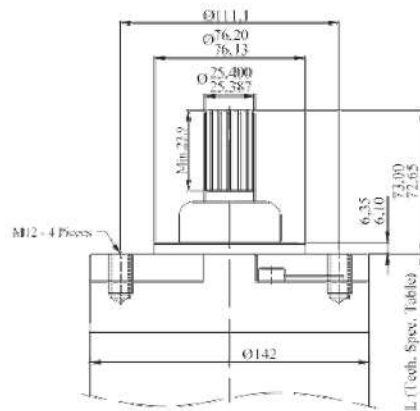

6" Motor

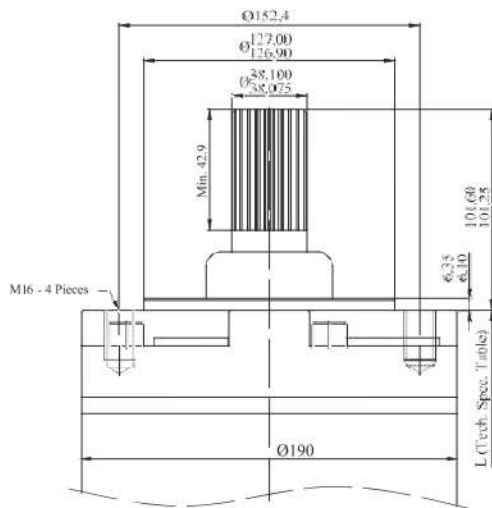

8" Motor

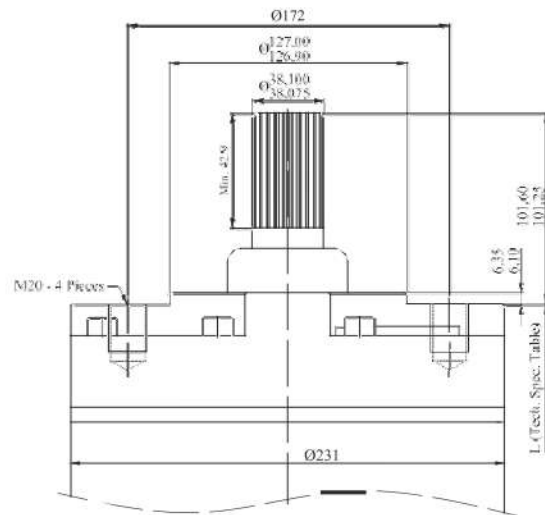

10" Motor

Cable Dimensions

Cable Type	Thickness	Width	Diameter
mm ²	(t) mm	(w) mm	(d) mm
3x2,5	6,4	15	3,6
3x4	7,1	16,5	4,1
3x6	8	18,3	4,6
3x10	8,8	21,8	6
3x16	10,5	25,4	7
3x25	12	33	9
3x35	13,5	34,5	10,1

Cable Type	Thickness	Width	Diameter
mm ²	(t) mm	(w) mm	(d) mm
4x2,5	18	18	3,6
4x4	20,2	20,2	4,1
4x6	22,4	22,4	4,6
4x10	28	28	6
4x16	33,7	33,7	7
4x25	40,1	40,1	9

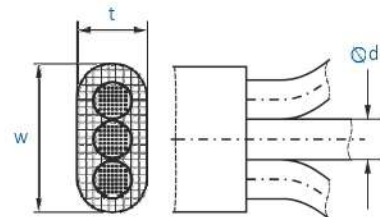

6" Submersible Motors

50 Hz

Type	R _i		Axial Load kN	Voltage V	n _N rpm	I _N A	I _A A	Efficiency (% load)			Cos Φ (% load)		
	HP	kW						50	75	100	50	75	100
VSM 6/5.5	5,5	4	20	380	2770	10,2	39,4	67	71	71	63	71	84
				400	2785	9,8	37,8	68	72	72	59	67	82
				415	2795	9,5	36,9	68	72	72	57,5	66	81
VSM 6/7.5	7,5	5,5	20	380	2780	13,3	52,7	70	73	75	63	71	84
				400	2795	12,8	50,6	71	74	76	59	67	82
				415	2805	12,3	48,7	72	75	77	57,5	66	81
VSM 6/10	10	7,5	20	380	2790	17,2	66,4	77	79	79	63	71	84
				400	2805	16,5	63,8	79	80	80	59	67	82
				415	2815	16,1	62,2	79	80	80	57,5	66	81
VSM 6/12.5	12,5	9,3	20	380	2850	20,8	80,3	80	81	81	63	71	84
				400	2855	20,2	78,1	80	81	81	59	67	82
				415	2865	19,5	75,3	81	82	82	57,5	66	81
VSM 6/15	15	11	20	380	2810	23,7	91,6	81	82	82	67	75	86
				400	2825	22,8	88,0	82	83	83	63	71	84
				415	2835	22,2	85,9	82	83	83	61	69	83
VSM 6/17.5	17,5	13	20	380	2820	28,7	110,9	80	81	81	65	73	85
				400	2835	27,6	106,6	81	82	82	61	69	83
				415	2845	26,6	102,7	82	83	83	59	67	82
VSM 6/20	20	15	20	380	2850	33,1	127,9	80	81	81	65	73	85
				400	2855	32,2	124,5	80	81	81	61	69	83
				415	2865	31,0	120,0	81	82	82	59	67	82
VSM 6/25	25	18,5	20	380	2850	41,8	161,6	80	81	81	61	69	83
				400	2865	40,2	155,4	81	82	82	57,5	66	81
				415	2875	38,8	149,8	82	83	83	56,5	65	80
VSM 6/30	30	22	20	380	2860	48,5	187,6	81	82	82	63	71	84
				400	2875	46,7	180,3	82	83	83	59	67	82
				415	2885	45,0	173,9	83	84	84	57,5	66	81
VSM 6/35	35	26,5	26,5	380	2870	56,4	217,9	83	84	84	65	73	85
				400	2885	54,9	212,0	83	84	84	61	69	83
				415	2895	52,9	204,4	84	85	85	59	67	82
VSM 6/40	40	30	26,5	380	2880	64,6	249,7	82	83	83	65	73	85
				400	2895	62,1	240,0	83	84	84	61	69	83
				415	2905	59,9	231,4	84	85	85	59	67	82
VSM 6/50	50	37	26,5	380	2890	79,7	315,6	80	81	83	65	73	85
				400	2905	76,7	303,3	81	82	84	61	69	83
				415	2915	74,7	288,8	83	84	84	59	67	82
VSM 6/60	60	45	26,5	380	2890	96,9	374,7	82	81	83	65	73	85
				400	2905	93,2	360,2	81	82	84	61	69	83
				415	2915	87,7	339,0	83	84	84	59	67	85

8" Submersible Motors

50 Hz

Type	R _n		Axial Load kN	Voltage V	n _n rpm	I _n A	I _A A	Efficiency (% load)			Cos Φ (% load)		
	HP	kW						50	75	100	50	75	100
VSM 8/40	40	30	45	380	2850	61,7	239	82	83	83	75	80	89
				400	2865	59,3	229	83	84	84	69	76	87
				415	2875	57,8	223	83	84	84	67	75	86
VSM 8/50	50	37	45	380	2860	74,3	287	84	85	85	75	80	89
				400	2875	71,4	276	85	86	86	69	76	87
				415	2885	69,6	269	85	86	86	67	75	86
VSM 8/60	60	45	45	380	2860	90,4	349	84	85	85	75	80	89
				400	2875	86,8	336	85	86	86	69	76	87
				415	2885	84,6	327	85	86	86	67	75	86
VSM 8/70	70	52	45	380	2850	103,3	399	84	85	85	77	83	90
				400	2865	99,2	383	85	86	86	72	78	88
				415	2875	96,7	374	85	86	86	69	76	87
VSM 8/75	75	55	45	380	2850	110,5	427	83	84	84	77	83	90
				400	2865	107,4	415	83	84	84	72	78	88
				415	2875	103,5	400	84	85	85	69	76	87
VSM 8/80	80	60	45	380	2850	119,1	460	85	86	86	75	80	89
				400	2865	115,7	447	85	86	86	69	76	87
				415	2875	112,9	436	85	86	86	67	75	86
VSM 8/90	90	67	45	380	2850	134,6	520	84	85	85	75	80	89
				400	2865	129,3	499	85	86	86	69	76	87
				415	2875	126,0	487	85	86	86	67	75	86
VSM 8/100	100	75	45	380	2850	150,7	582	83	84	84	77	83	90
				400	2865	144,7	559	84	85	85	72	78	88
				415	2875	141,1	545	84	85	85	69	76	87
VSM 8/110	110	81	55	380	2855	162,7	629	84	85	85	75	80	89
				400	2860	156,3	604	85	86	86	69	76	87
				415	2865	152,4	589	85	86	86	67	75	86
VSM 8/125	125	92	55	380	2820	184,8	714	84	85	85	75	80	89
				400	2835	177,5	686	85	86	86	69	76	87
				415	2850	173,1	669	85	86	86	67	75	86
VSM 8/135	135	100	55	380	2920	200,8	776	84	85	85	75	80	89
				400	2925	192,9	746	85	86	86	69	76	87
				415	2935	188,1	727	85	86	86	67	75	86
VSM 8/150	150	110	55	380	2900	218,5	844	84	85	85	74	80	90
				400	2910	207,4	802	85	86	86	69	76	89
				415	2915	199,9	773	85	86	86	67	75	89

10" Submersible Motors

50 Hz

Type	P _N		Axial Load kN	Voltage V	n _N rpm	I _N A	I _A A	Efficiency (% load)			Cosφ (% load)		
	HP	kW						50	75	100	50	75	100
VSM 10/110	110	81	75	380	2880	159	615	84	85	85	78,5	84	91
				400	2895	153	590	85	86	86	74,5	80	89
				415	2905	147	569	86	87	87	71,5	78	88
VSM 10/125	125	92	75	380	2890	179	690	85	86	86	78,5	84	91
				400	2905	174	671	85	86	86	74,5	80	89
				415	2915	169	654	85	86	86	71,5	78	88
VSM 10/150	150	110	75	380	2890	216	835	85	86	86	77,0	83	90
				400	2905	210	811	85	86	86	71,5	78	88
				415	2915	205	791	85	86	86	68,5	76	87
VSM 10/175	175	129	75	380	2910	248	957	86	87	87	78,5	84	91
				400	2925	238	919	87	88	88	74,5	80	89
				415	2935	232	896	87	88	88	71,5	78	88
VSM 10/200	200	147	75	380	2900	282	1090	86	87	87	78,5	84	91
				400	2915	274	1059	86	87	87	74,5	80	89
				415	2925	264	1020	87	88	88	71,5	78	88
VSM 10/225	225	166	75	380	2890	322	1245	85	86	86	78,5	84	91
				400	2905	309	1196	86	87	87	74,5	80	89
				415	2915	302	1165	86	87	87	71,5	78	88
VSM 10/250	250	185	75	380	2895	359	1388	85	86	86	78,5	84	91
				400	2905	349	1348	85	86	86	74,5	80	89
				415	2915	336	1299	86	87	87	71,5	78	88
VSM 10/300	300	220	75	380	2895	427	1.651	85	86	86	79	84	91
				400	2905	415	1.604	85	86	86	75	80	89
				415	2915	400	1.546	86	87	87	72	78	88

6" Submersible Motors

60 Hz

Type	R _i		Axial Load kN	Voltage V	n _n rpm	I _N A	I _A A	Efficiency (% load)			Cos Φ (% load)		
	HP	kW						50	75	100	50	75	100
VSM 6/5.5	5,5	4	20	460	3350	8,4	44	69	70	70	65	74	85
VSM 6/7.5	7,5	5,5	20	460	3360	11,3	59	71	72	72	65	74	85
VSM 6/10	10	7,5	20	460	3380	14,2	73	77	78	78	65	74	85
VSM 6/12.5	12,5	9,3	20	460	3390	17,4	90	78	79	79	65	74	85
VSM 6/15	15	11	20	460	3400	19,6	101	80	81	81	67	76	87
VSM 6/17.5	17,5	13	20	460	3410	23,4	121	80	81	81	66	75	86
VSM 6/20	20	15	20	460	3440	27,3	141	79	80	80	66	75	86
VSM 6/25	25	18,5	20	460	3450	34,5	178	79	80	80	64	73	84
VSM 6/30	30	22	20	460	3460	40,1	207	80	81	81	65	74	85
VSM 6/35	35	26,5	26,5	460	3470	47,1	242	81	82	82	66	75	86
VSM 6/40	40	30	26,5	460	3480	53,4	272	81	82	82	66	75	86
VSM 6/50	50	37	26,5	460	3490	66,6	341	80	81	81	66	75	86
VSM 6/60	60	45	26,5	460	3490	82,1	415	80	81	80	66	75	86

8" Submersible Motors

60 Hz

Type	R _N		Axial Load kN	Voltage V	n _N rpm	I _N A	I _A A	Efficiency (% load)			Cos Φ (% load)		
	HP	kW						50	75	100	50	75	100
VSM8/40	40	30	45	460	3450	51,0	258	83	83	82	82	86	90
VSM8/50	50	37	45	460	3460	61,4	308	85	85	84	82	86	90
VSM8/60	60	45	45	460	3460	74,8	382	85	85	84	82	86	90
VSM8/70	70	52	45	460	3450	85,3	431	85	85	84	83	87	91
VSM8/75	75	55	45	460	3450	90,2	458	85	85	84	83	87	91
VSM8/80	80	60	45	460	3450	99,6	509	85	85	84	82	86	90
VSM8/90	90	67	45	460	3450	111,2	563	85	85	84	82	86	90
VSM8/100	100	75	45	460	3450	123,1	625	85	85	84	82	86	91
VSM8/110	110	81	55	460	3430	134,4	681	85	85	84	82	86	90
VSM8/125	125	92	55	460	3430	152,8	770	85	85	84	82	86	90
VSM8/135	135	100	55	460	3430	166,0	837	85	85	84	82	86	90
VSM8/150	150	110	55	460	3430	182,6	920	85	85	84	82	86	90

10" Submersible Motors

60 Hz

Type	R _N		kN	Voltage V	n _N rpm	I _N A	I _A A	Efficiency (% load)			Cos Φ (% load)		
	HP	kW						50	75	100	50	75	100
VSM 10/110	110	81	75	460	3490	131,5	663	84	84	84	87	90	92
VSM 10/125	125	92	75	460	3500	149,4	748	84	84	84	87	90	92
VSM 10/150	150	110	75	460	3500	180,5	910	84	85	84	86	89	91
VSM 10/175	175	129	75	460	3510	207,0	1.050	85	86	85	87	90	92
VSM 10/200	200	147	75	460	3500	236,0	1.197	85	85	85	87	90	92
VSM 10/225	225	166	75	460	3490	266,2	1.347	85	85	85	87	90	92
VSM 10/250	250	185	75	460	3490	297,0	1.502	85	85	85	87	90	92
VSM 10/300	300	220	75	460	3490	353,1	1.786	85	85	85	87	90	92

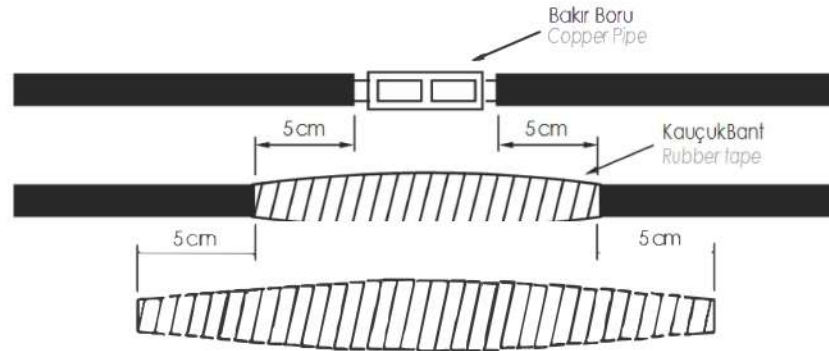

PVC

Power Cable Connection

Connection of the power cable that will be used along the well and until the control panel with the power cable on the motor must be done very carefully and by the professionals only. Unless the insulation after the connection is well done, shortcircuit might happen when the connection area is in the water.

Insulation of each cable should be stripped only as far as necessary to provide room for a stake type connector. Each individual joint should be taped with pvc tape, using two layers by wrapping tightly for eliminating airspaces as much as possible.

Total thickness of tape should be no less than the thickness of the cable insulation in order to prevent the smashing of the cables when the pump is lowered in the well.

Motor Water Filling

During the storage and delivery period, an antifreeze is used not to cause any freezing. VANSAN submersible motors are filled with water +antifreeze mix before shipment to protect rotor till -10°C freezing temperature.

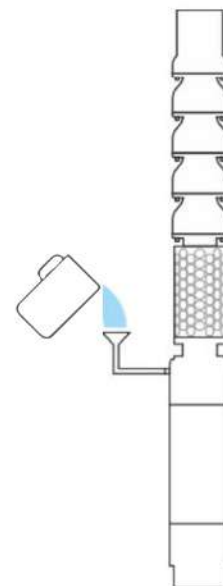

Before the installation of the motor to the well, water level inside the motor should be checked. Position the motor horizontally and remove the screw 1 and 2, fill the motor with clean water if it is not full. After waiting 30 minutes with the filling screw open, fill the water completely again and tighten the screw providing leakage.

Use Cooling Jacket

Cooling of submersible motors is provided with the flow of the water around it. That's allows waterflow around motors has vital importance during submersible pump installation. This flow rate depends on diameter and power of motor.

Most important factor of submersible motors' long service life is that the motor has to be cooled well. Required flow velocity around the motor is given in the table below for motors being cooled well enough.

If the motor will be installed in an open body of water (i. e. pool) or diameter of the wells much bigger than the diameter of the motor, Flow Inducer Sleeve must be used to provide the flow velocities that are given in the table below, around the motor.

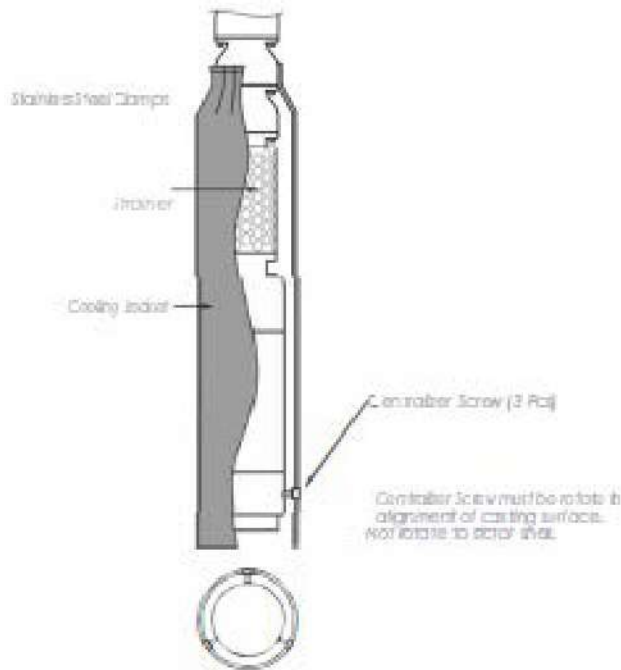

Motor Type	Motor Rating	Min. Water Flow(m/s)
6"	5.5-18.5kW	0.2
	22-37 kW	0.5
7"	22 - 55 kW	0.2
8"	30-55 kW	0.2
	60-92 kW	0.5
10"	81 - 110 kW	0.5

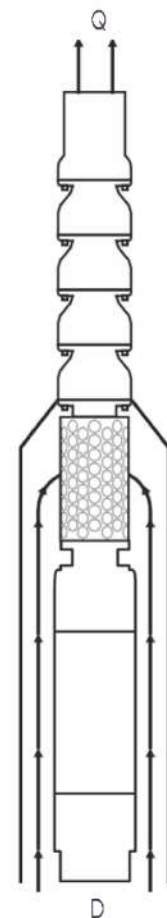
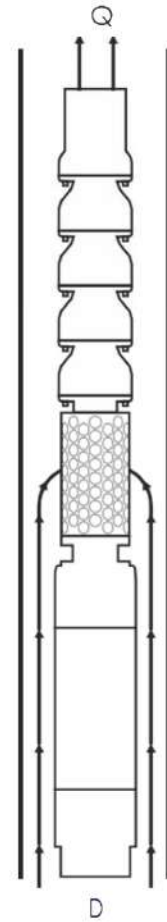

Insulation Resistance Test

All Sistema motors are applied insulation test under 3.000 V before shipment. Motors which have at least 2.000 megaohm test result are shipped. Insulation test results should be controlled before the installation and after connecting power cables as it is explained below. Meger tester's one probe should be touched to motor body and other probe should be touched to tip of each power cable to measure the insulation of each phase.

If there is any short circuit in a phase, insulation value is 0 megaohm.

Under the normal operating conditions, a motor inside the well should have 2 megaohm insulation resistance. When the insulation resistance drops under 0.5 megaohm, there might be a insulation problem in winding.

Test voltage should be at least 500 V DC.

After extending power cables with a joint, same test procedures should be also applied for insulation control while power cables are inside water. If insulation test result for any winding is lower than 100 megaohm, cable joint should be done again.



Use Frequency Convertor and Soft Starter

These points listed below should be taken into consideration while operating submersible motors with frequency convertor and soft starter.

Needed precautions should have been taken to protect your frequency convertor from voltage fluctuations.

Flow rate around motor must be at least 0,15 m/s. If flow rate is not enough, flow inducer sleeve must be used to provide the needed flow rate.

In systems which are operated by frequency convertor and soft starter, motor selection should be done as choosing next higher motor rate for pumps will provide long service life for motors.

Motors should be operated between 30-50 Hz with frequency convertors. As the protective water layer can't be formed on thrust bearing at the lower frequencies, motor would get damaged.

Dual slope frequency convertors should be used while using soft starter too.



Voltage Drop and Cable Power Loss

To determine the cable section it should be considered that the voltage drop must not exceed 3%. The formulas used for voltage drop calculation are given below.

Direct starter

$$\text{1 cable} \quad U_v = \frac{3,1 \times L \times I \times \cos\varphi}{q \times U} \quad q = \frac{3,1 \times L \times I \times \cos\varphi}{U_v \% \times U}$$

$$\text{2 cables in parallel} \quad U_v = \frac{1,55 \times L \times I \times \cos\varphi}{q \times U} \quad q = \frac{1,55 \times L \times I \times \cos\varphi}{U_v \% \times U}$$

Star-delta starter

$$U_v = \frac{2,1 \times L \times I \times \cos\varphi}{q \times U} \quad q = \frac{2,1 \times L \times I \times \cos\varphi}{U_v \% \times U}$$

- L : Cable length (m)
- I : Current at nominal voltage (A)
- q : Conductor section (mm²)
- cosφ : Power factor
- P_v : Power loss (%)
- U_v : Voltage drop (%)
- U : Nominal voltage (V)

The power loss along the feeling cable has to be calculated adjacent to

$$P_v = \frac{U_v}{\cos^2\varphi}$$

Energy Connection Schema

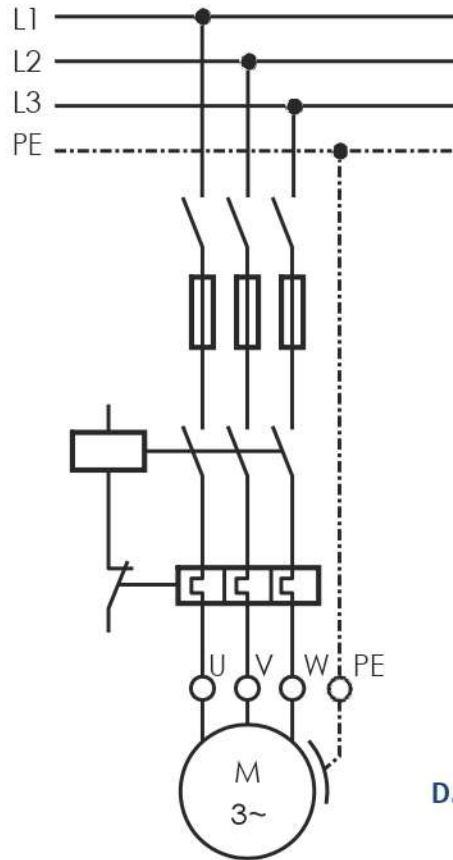

D.O.L Connection

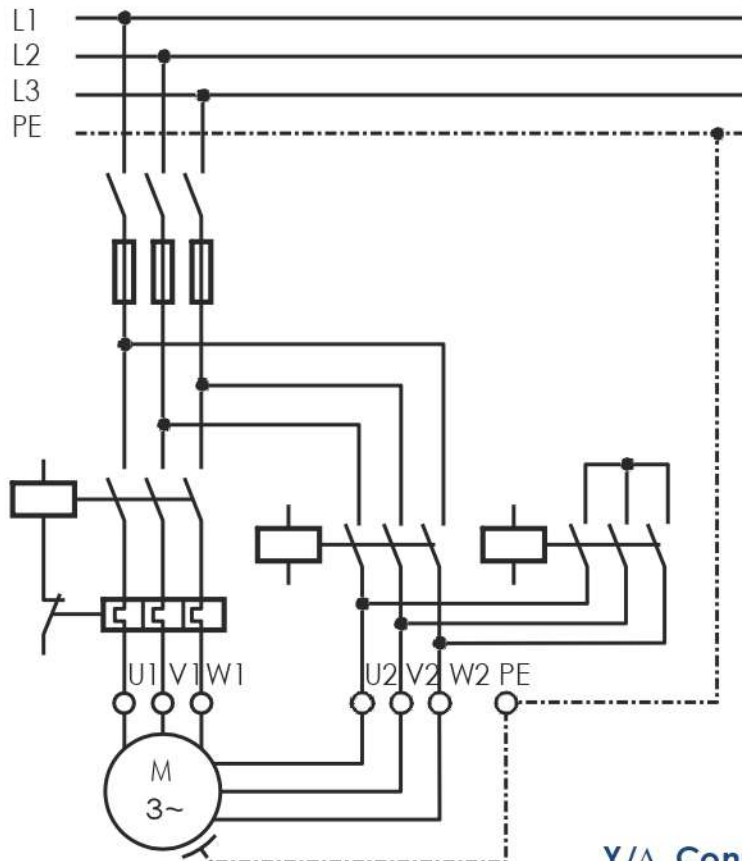

Y/Δ Connection

Trouble Shooting

Motor Does Not Start

Possible Cause	Remedy
No power or incorrect voltage	Check voltage at lines. Contact power company if voltage is incorrect
Fuses blown or circuit breakers tripped	Replace with proper fuse or reset circuit breakers
Control box malfunction	Repair or replace
Defective wiring	Correct faulty wiring or connections
Bound pump	Pull pump and correct problem. Run new installation until the water cleans
Defective cable or motor	Repair or replace

Motor Starts Too Often

Possible Cause	Remedy
Check valve stuck open	Replace if defective
Waterlogged tank	Repair or replace
Leak in system	Replace damaged pipes or repair leaks

Motor Runs Continuously

Possible Cause	Remedy
Low water level in well	Throttle pump outlet or reset pump to lower level. Do not lower if sand may clog pump
Worn pump	Pull pump and replace worn parts
Loose coupling or broken motor shaft	Replace worn or damaged parts
Pump screen blocked	Clean screen and reset pump depth
Check valve stuck closed	Replace if defective
Control box malfunction	Repair or replace

Motor Runs But Overload Protector Trips

Possible Cause	Remedy
Incorrect voltage	Contact power company if voltage is incorrect
Overheated protectors	Shade box, provide ventilation or move box away from source
Defective control box	Repair or replace
Defective motor or cable	Repair or replace
Worn pump or motor	Replace pump and/or motor

